

S9074-AR-GIB-010A/278

NAVSEA TECHNICAL PUBLICATION

REQUIREMENTS FOR FABRICATION WELDING AND INSPECTION, AND CASTING INSPECTION AND REPAIR FOR MACHINERY, PIPING, AND PRESSURE VESSELS



DISTRIBUTION STATEMENT A: APPROVED FOR PUBLIC RELEASE; DISTRIBUTION UNLIMITED

PUBLISHED BY DIRECTION OF COMMANDER, NAVAL SEA SYSTEMS COMMAND

S9074-AR-GIB-010



0910-LP-731-4600

01 AUGUST 1995

CHANGE A 14 FEBRUARY 2013

**DEPARTMENT OF THE NAVY
NAVAL SEA SYSTEMS COMMAND
WASHINGTON NAVY YARD, DC 20376-5160**

**REQUIREMENTS FOR FABRICATION
WELDING AND INSPECTION, AND
CASTING INSPECTION AND REPAIR FOR
MACHINERY, PIPING, AND PRESSURE
VESSELS**

**S9074-AR-GIB-010/278
Change A
14 February 2013
Page 1 of 24 pages**

-
1. This is Change A to the Technical Manual S9074-AR-GIB-010/278. The purpose of this change is to clarify visual inspection requirements for nonferrous castings and titanium weld color.
 2. All holders of this technical manual shall incorporate this change upon receipt.

NOTE

The portion of the text affected by this change is indicated by change bars in the outer margin of each changed page. Entire procedures that have been changed are indicated by a change bar in the outer margin next to the specific procedure (paragraph) title.

3. Incorporate the attached enclosures as follows:

<u>Remove</u>	<u>Insert</u>
Title Page	Title Page
Certification Sheet	Certification Sheet
i-ii	Change A i-ii
vii-viii	vii/Change A viii
ix-x	ix/Change A x
None	Change A xi/xii
17-18	Change A 17/18
97-98	Change A 97/98
111-112	111/Change A 112-112.2
Standardization Document Improvement Proposal (2)	None
TMDER NAVSEA 4160/1 (Rev. 7-2003)	TMDER NAVSEA 4160/1 (Rev. 9-2010)

4. After the attached enclosures have been inserted, record this change on the change record sheet and insert this change guide behind the front cover.

DISTRIBUTION STATEMENT A: APPROVED FOR PUBLIC RELEASE; DISTRIBUTION UNLIMITED

0910-LP-113-2508



S9074-AR-GIB-01A

NAVSEA TECHNICAL PUBLICATION CERTIFICATION SHEET

1 of 1

Certification Applies to: New Document Revision Change

Applicable TMIN/Pub. No. S9074-AR-GIB-010A/278

Publication Date (Mo, Day, Yr) 02/14/13

Title: REQUIREMENTS FOR FABRICATION WELDING AND INSPECTION, AND CASTING INSPECTION AND REPAIR FOR MACHINERY, PIPING, AND PRESSURE VESSELS

CHANGES AND REVISIONS

Purpose: To clarify visual inspection requirements for nonferrous castings and titanium weld color.

TMDER/ACN Numbers Incorporated: None

Continue on reverse side or add pages as needed

CERTIFICATION STATEMENT

This is to certify that responsible NAVSEA activities have reviewed the above identified document for technical adequacy and suitability for the intended use. This form is for internal NAVSEA management use only, and does not imply contractual approval or acceptance of the technical publication by the Government.

Name	Signature	Organization	Code	Date
W.E. Mitchell		NAVSEA	05P2	02/14/13

RECORD OF REVISIONS

<u>REVISION NO.</u>	<u>DATE</u>	<u>ENTERED BY</u>
0	01 August 1995	Complete Reprint Incorporated
Change A	14 February 2013	Change Package

LIST OF EFFECTIVE PAGES

Insert latest changed pages and dispose of superseded pages in accordance with applicable regulations.

Dates of issue for original and subsequent revisions:

Original..... 0 01 August 1995
Change..... A 14 February 2013

TOTAL NUMBER OF PAGES IN THIS PUBLICATION IS 162, CONSISTING OF THE FOLLOWING:

Page No.	*Change No.
Title page.....	A
i-ii.....	A
iii-vii.....	0
viii.....	A
ix.....	0
x-xi/xii.....	A
1-16.....	0
17.....	A
18-96.....	0
97.....	A
98-111.....	0
112-112.2.....	A
113-142.....	0

*Zero in this column indicates an original page.

CONTENTS

<u>PARAGRAPH</u>		<u>PAGE</u>
1.	SCOPE	
1.6	Requirements subject to NAVSEA approval	1
1.7	Document precedence	1
2.	REFERENCED DOCUMENTS	
2.1	Government documents	3
2.1.1	Specifications and standards	3
2.1.2	Other Government publications	8
2.2	Other publications	9
3.	GENERAL REQUIREMENTS	
3.1	Responsibility	14
3.2	Engineering drawings	14
3.2.1	Referencing this document	14
3.3	Nomenclature and definitions	14
3.3.1	Definitions	14
3.3.1.1	Activity	14
3.3.1.2	Approved (approval)	14
3.3.1.3	Arc-strike	14
3.3.1.4	Authorized representative	14
3.3.1.5	Diving life support piping systems	15
3.3.1.6	Dissimilar metal welds	15
3.3.1.7	Essential elements	15
3.3.1.8	Fabrication welds	15
3.3.1.9	Government inspector	15
3.3.1.10	Lethal fluids	15
3.3.1.11	Organization inspector	16
3.3.1.12	Pressure containing	16
3.3.1.13	Procedure qualification	16
3.3.1.14	Qualified	16
3.3.1.15	Seal welds	16
3.3.1.16	Tube-to-header "seal" welds	16
3.3.1.17	Welding deposited buttering	16
3.3.1.18	Weld-deposited overlay cladding	16
3.3.1.19	Weld deposited hard surfacing	16
3.3.1.20	Welded fabrication or weldment	16
3.3.1.21	Welding procedure	16
3.3.1.22	Straw (color)	17
3.3.2	Classification	17
4.	QUALITY ASSURANCE AND QUALIFICATION PROVISIONS	
4.1	Quality assurance	21
4.1.1	General	21
4.1.2	Material control	21
4.1.2.1	Quality assurance system	21
4.1.2.2	Material Control - special requirements for MIL-120 and MIL-140 series filler materials	21
4.1.3	Records - applicable to classes A-F, A-1, A-2, A-3, A-LT, P-1, P-LT, M-1, and T-1	21

CONTENTS - continued

<u>PARAGRAPH</u>		<u>PAGE</u>
4.1.3.1	Record form	22
4.1.3.2	Maintenance of records	22
4.1.4	Nonconformance	23
4.2	Welding qualification (procedure, welder, and operator requirements)	23
4.2.1	Welding procedure	23
4.2.1.1	Conditions governing welding procedure qualification tests	23
4.2.1.2	Approval of procedure qualification data	24
4.2.1.3	Welding procedure qualification - special requirements for MIL-120 and MIL-140 series filler materials	24
4.3	Welder, tack welder, and welding operator qualification	24
4.3.3	Welder and welding operator performance qualification - special requirements for MIL-120 and MIL-140 series filler materials	24
4.4	Welding equipment	24
4.5	NDT personnel	25
4.6	Approval for fabrication and welding of titanium and titanium alloys	25
5.	MATERIALS	
5.1	General	26
5.2	General requirements	26
5.2.1	Material substitution approval	26
5.2.2	Specification deviations	47
5.2.3	Exceptions	47
5.3	Material inspection	48
5.3.1	Material identification	48
5.3.2	Filler material inspection	48
6.	WELDING REQUIREMENTS AND CONTROLS	
6.1	General	49
6.1.1	Gas metal-arc welding - short circuiting transfer (GMAW short arc) restriction	49
6.2	Welding processes and filler materials	49
6.2.1	Oxyacetylene restrictions	49
6.2.2	Class P material thickness limitation	49
6.2.3	Covered electrodes for class P-1 carbon steel pipe	49
6.2.4	Prohibited electrodes	49
6.2.5	Selection of filler materials	49
6.2.5.1	Filler materials for steam service applications	53
6.2.6	Number of weld passes	53
6.2.7	Weld back side shielding	54
6.2.8	Age hardenable alloys	54
6.3	Preheat and interpass temperatures	54
6.3.1	Methods of preheating and interpass temperature control	60
6.3.1.1	Titanium and titanium alloys	60
6.3.2	Verifying temperatures	61
6.4	Postheating	61
6.4.1	Nickel alloys	69
6.4.2	Aluminum alloys	69

CONTENTS - continued

<u>PARAGRAPH</u>		<u>PAGE</u>
6.4.3	Alloys not specifically covered	69
6.4.4	Age hardenable alloys	69
6.4.5	Copper alloys	69
6.4.6	Titanium and titanium alloys	70
6.4.6.1	General heat treating requirements	70
6.4.6.2	Stress relieving	70
6.4.6.3	Annealing	70
6.5	Special requirements for welding and forming S-11 steels and special treatment steels (STS)	70
6.5.1	Special requirements for welding with MIL-120 and MIL-140 series filler materials	70
6.6	Electrode handling and storage	70
6.6.1	General	70
6.6.1.1	Covered electrodes (excluding MIL-types 9018, 10018, 11018, 12018, 10018-N1, and 410NiMo)	71
6.6.2	Conditioning electrodes (MIL-types 9018, 10018, 11018, 12018, 10018-N1, and 410NiMo and type E2209-15/16)	71
6.6.2.1	Exposed electrodes	71
6.6.2.2	Storage in holding ovens	71
6.6.2.3	Baking	71
6.6.2.3.1	Rebaking	71
6.6.2.4	Moisture test	71
6.6.3	Submerged arc granular flux for general welding	71
6.6.3.1	Storage	71
6.6.3.2	Reuse	72
6.6.4	Submerged-arc granular flux for welding high hardenable alloys	72
6.6.4.1	Preparation for use	72
6.6.4.2	Reuse	72
6.6.5	Titanium and titanium alloy electrodes	72
6.7	Production bend test for titanium and titanium alloys	72
7.	WORKMANSHIP REQUIREMENTS	
7.1	General	73
7.2	Cleaning prior to and during welding	73
7.2.1	Seal welding in areas having threaded connections	73
7.2.2	Titanium preweld preparation	73
7.2.3	Titanium interpass cleaning	73
7.3	Peening of welds	73
7.4	Butt welds	74
7.5	Thermal cut surfaces	74
7.6	Alignment of joint members	74
7.7	Repairs	74
7.8	Marking	75
7.9	Defect removal	75
7.10	Titanium and titanium alloy welds	76
7.10.1	Thermal gouging	76
7.10.2	In process color inspection	76

CONTENTS - continued

<u>PARAGRAPH</u>		<u>PAGE</u>
8.	POST WELD HEAT TREATMENT	77
8.1	General	77
8.2	Special requirements	77
8.2.1	Dissimilar metal joints	77
8.2.2	Post-weld heat treatment for different thicknesses of plate in pressure vessels	77
8.3	Ferrous material	77
8.4	Nonferrous material	77
8.5	Post-weld heat treatment procedures (furnace)	77
8.5.1	Loading temperature	77
8.5.2	Rate of heating	77
8.5.3	Temperature variation during heating and cooling cycles	78
8.5.4	Holding temperature variation	78
8.5.5	Preventing oxidation and distortion	78
8.5.6	Rate of furnace cooling	78
8.5.7	Special considerations (heating or cooling rates)	78
8.6	Post-weld heat treatment procedures (local)	78
8.6.1	Heating method	78
8.6.2	Heating rate, holding temperature variation, and cooling rate	78
8.6.3	Postheating piping welds	78
8.6.4	Postheating pressure vessels	79
8.7	Postheating repaired welds in pressure vessels and piping	79
8.8	Heat treatment of titanium and titanium alloys	79
8.9	Temperature measuring methods	79
8.9.1	Pyrometric equipment	79
8.9.2	Locating thermocouples	79
8.9.3	Installing thermocouples	80
8.9.4	Pyrometrically controlled furnaces	80
9.	DESIGN REQUIREMENTS FOR WELDED JOINTS	81
9.1	General	81
9.2	Joint design	85
9.3	Joint efficiency	85
9.3.1	Fillet welds	85
9.3.1.1	Continuous double fillet tee or continuous double fillet lap welded joints	85
9.3.1.2	Fillet joints welded all around	85
9.3.2	Joints other than fillet welds	85
9.3.2.1	Full penetration joints	85
9.3.2.1.1	Full penetration joints welded from both sides	85
9.3.2.1.2	Full penetration joints welded from one side	85
9.3.2.2	Partial penetration joints	86
10.	INSPECTION REQUIREMENTS	87
10.1	General	87
10.2	Performing NDT	87
10.3	Extent of inspection and methods	87
10.3.1	Class M machinery	87
10.3.2	Class P piping	88

S9074-AR-GIB-010A/278

CONTENTS – Continued

<u>PARAGRAPH</u>		<u>PAGE</u>
10.3.3	Class A pressure vessels and class T turbines	91
10.3.4	Repaired welds	93
10.3.5	Base metal repair.....	93
10.3.6	Weld deposited cladding, hardsurfacing, and buttering	94
10.3.7	Loss of preheat and interpass	94
10.3.8	Tack welds	95
10.3.9	Seal welds	95
10.3.10	Substitution of VT inspection	95
10.3.11	Non-structural welds	95
10.3.12	MT inspection for MIL-140S, MIL120S and MIL-12018 welds in class A-F A-1, A-2, A-LT, P-1, P-LT and M-1 (Category A and B)	95
10.3.13	Titanium and titanium alloy welds.....	95
10.4	Acceptance standards	96
10.4.1	Visual examination	96
10.4.1.1	General	97
10.4.1.2	Welds	97
10.4.1.3	Base material.....	97
10.4.2	MT and PT inspection.....	97
10.4.2.1	Adjacent casting base material.....	97
10.4.3	Radiography	98
10.4.4	UT inspection.....	98
10.4.4.1	UT inspection of weld deposited buttering	98
10.4.4.1.1	Calibration for inspecting weld deposited buttering for both weld metal defects and lack of bond	98
10.5	Disposition of rejected welds	100
10.6	Hardness testing of titanium and titanium alloy flame cut surfaces.....	100
11.	ALLIED PROCESSES	101
11.1	General	101
11.2	Thermal spraying	101
11.3	Thermal cutting	101
11.3.1	Titanium and titanium alloys	101
11.4	Resistance welding.....	101
11.5	Stud welding	101
11.5.1	General	101
11.5.1.1	Bend testing	101
11.5.1.2	Torque testing	102
11.5.1.3	Rejection procedure	103
11.5.2	Pressure containing applications	104
11.5.3	Nonpressure containing applications	104
11.5.4	Temporary attachments	104
11.5.5	Repair to studs.....	104
11.6	Hard surfacing valve parts	104
11.6.1	Preheating and heat treatment of carbon and alloy steel	104
11.6.2	Inspection	104
11.6.3	Acceptance	104
11.7	Pipe and tube bending	104

CONTENTS – Continued

<u>PARAGRAPH</u>	<u>PAGE</u>
12. CASTING INSPECTION.....	105
12.1 General.....	105
12.2 Definitions.....	105
12.2.1 Pressure containing	105
12.2.2 Sub-category	105
12.3 Inspection details	111
12.3.1 General.....	111
12.3.2 Visual examination	111
12.3.2.1 Inspection qualification.....	111
12.3.3 NDT	111
12.3.4 Radiographic standard shooting sketches	111
12.3.5 Substitution of tests.....	112
12.4 Acceptance criteria.....	112
12.4.1 Visual examination	112
12.4.2 MT, PT and RT	112.2
12.4.2.1 RT evaluations	118
12.4.2.2 Investment castings	118
12.4.3 Pressure test	118
12.4.4 UT	118
12.5 Extent of NDT.....	118
12.5.1 VT	118
12.5.2 Pressure tests	118
12.5.3 Extent of radiography.....	118
12.5.4 Extent of MT or PT inspection for ferrous castings.....	119
12.5.5 Extent of PT for nonferrous castings	119
12.5.6 Records for NDT of castings.....	119
12.6 NDT responsibilities	119
12.6.1 Designer responsibility	119
12.6.2 Contractor responsibility.....	119
12.6.3 Approvals.....	120
12.6.3.1 Engineering drawings	120
12.7 Weldability tests.....	120
12.8 Sample castings.....	120
13. REPAIR OF CASTINGS.....	121
13.1 Impregnation	121
13.1.1 Impregnation authority.....	121
13.1.2 Impregnation procedure	121
13.2 Repair welding	121
13.2.1 General.....	121
13.2.2 Minor repairs.....	121
13.2.3 Nominal repairs.....	122
13.2.4 Special repairs.....	122
13.2.5 Authority for repair of castings	122
13.2.5.1 Repair procedures and report	122
13.2.6 Heat treated weld repairs.....	122
13.2.7 Stress relief of weld repairs.....	123
13.2.7.1 Alternate temperature measuring methods for furnace and local stress relief.....	123

S9074-AR-GIB-010A/278

CONTENTS – Continued

<u>PARAGRAPH</u>		<u>PAGE</u>
13.2.8	Inspection of repair welds	123
13.2.8.1	Exploration and repair of cracks	123
13.2.8.2	Surface passes	123
13.2.8.3	Radiography of completed repair	124
13.2.9	Acceptance standards for repair welds	124
13.2.10	Records	125
13.2.10.1	Maintenance of records	126
13.2.11	Repair welding on existing shipboard castings	126
14.	NDT REQUIREMENTS FOR TURBINE PARTS	127
14.1	General	127
14.2	Inspection requirements	128
14.2.2	Radiography of castings and steam chests	129
14.3	Performing NDT inspection	129
14.3.2	Radiographic standard shooting sketches	129
14.4	Acceptance standards for NDT inspection	129
14.4.1	Radiography	129
14.4.2	MT and PT inspection of welds	129
14.4.3	MT and PT inspection of castings	129
14.5	UT inspection	129
14.6	Additional inspection for ferritic materials	129
15.	NDT INSPECTION REQUIREMENTS FOR PROPULSION REDUCTION GEARS AND STEAM TURBINE DRIVEN AUXILIARY GEARS	130
15.1	General	130
15.2	Inspection requirements	130
15.3	Performing NDT inspection	131
15.4	Acceptance standards for NDT inspection	131
15.4.1	MT and PT inspection of welds	131
15.4.2	MT and PT inspection of castings	131
15.5	UT inspection	131
15.6	Additional inspection for ferritic materials	131
16.	NDT INSPECTION REQUIREMENTS FOR FORCED DRAFT BLOWERS	132
16.1	General	132
16.2	Inspection requirements	132
16.3	Performing NDT inspection	132
16.3.2	Radiographic standard shooting sketches	132
16.4	Acceptance standards for NDT inspection	132
16.4.1	Radiography	132
16.4.2	MT and PT inspection of welds	132
16.4.3	MT and PT inspection of castings	132
16.5	UT inspection	133
16.6	Additional inspection for ferritic materials	133
17.	NOTES	134
17.1	Cancelled specifications	134
Appendix		
A	Additional requirements for welding titanium and titanium alloys	136

TABLES

<u>TABLE</u>		<u>PAGE</u>
I.	Grouping of base materials (welding).....	26
II.	Grouping of filler materials (welding)	39
III.	Welding filler material chart	50
IV.	Preheat and interpass temperature for welded ferrous alloys	55
V.	Preheat and interpass temperature for welded nonferrous alloys	58
VI.	Post heat requirements for welded ferrous alloys	62
VII.	Approved weld joint designs	82
VIII.	Class M machinery inspection requirements.....	87
IX.	Class P piping inspection requirements	88
X.	Class A pressure vessel inspection requirements	91
XI.	Acceptance standards and classes.....	96
XII.	Torque-tension minimum values (80 percent of yield strength)	103
XIII.	Category 1. non-pressure containing castings in machinery or pressure vessels	106
XIV.	Category 2. pressure containing castings - machinery or pressure vessel castings	108
XV.	Category 3. pressure containing castings - piping system castings - valves, fittings, flanges and auxiliary equipment	109
XV.1.	Nonferrous casting VT acceptance criteria.....	112
XVI.	Acceptance criteria for MT and PT	112.2
XVII.	RT acceptance criteria for aluminum castings	113
XVIII.	RT acceptance criteria for steel (carbon alloy and corrosion resistant), titanium, and titanium alloy castings	114
XIX.	RT acceptance criteria for nonferrous castings	116
XX.	RT acceptance criteria for tin-bronze castings	117
XXI.	NDT inspection of turbine parts	121
XXII.	NDT inspection of propulsion reduction gear parts (including steam turbine driven auxiliary gears)	130
XXIII.	NDT inspection requirements for forced draft blowers.	132

FIGURES

<u>FIGURE</u>		<u>PAGE</u>
1.	Examples of acceptable weld joint locations	81
2.	Maximum acceptable ultrasonic indication length for weld deposited buttering.....	100
3.	Device for testing welded studs	102
4.	Illustration of welded joint location	142

FOREWORD

This manual covers the general requirements for fabrication welding and inspection, and casting inspection and repair for machinery, piping, and pressure vessels.

TMDER INSTRUCTIONS

Ships, training activities, supply points, depots, Naval Shipyards and Supervisors of Shipbuilding are requested to arrange for the maximum practical use and evaluation of NAVSEA and SPAWAR technical manuals (TMs). All errors, omissions, discrepancies, and suggestions for improvement to NAVSEA and SPAWAR TMs shall be submitted as a Technical Manual Deficiency/Evaluation Report (TMDER). All feedback comments shall be thoroughly investigated and originators will be advised of action resulting there from.

The NAVSEA/SPAWAR Technical Manual Deficiency/Evaluation Report form, NAVSEA 4160/1, is included at the back of the TM.

Copies of form NAVSEA 4160/1 may also be downloaded from:

https://nsdsa.nmci.navy.mil/nsdsarepository/TMDER_BLANK_REV_9-2010-1.pdf

The following methods are available for generation and submission of TMDERs against unclassified TMs:

- For those with a Technical Data Management Information System (TDMIS) account, the most expedient and preferred method of TMDER generation and submission is via the TDMIS website at: <https://mercury.tdmis.navy.mil>.
- For those without a TDMIS account, generate and submit TMDER via the Naval Systems Data Support Activity (NSDSA) website at: https://mercury.tdmis.navy.mil/def_external/pubsearch.cfm. (TDMIS accounts may be requested at <https://nsdsa.nmci.navy.mil>.)
- When internet access is not available, submit TMDER via hardcopy to:
COMMANDER
CODE 310 TMDERs
NAVSURFWARCENDIV NSDSA
4363 MISSILE WAY, BLDG 1389
PORT HUENEME, CA 93043-4307
- TMDERs against classified/restricted (includes all NOFORN) TMs must be submitted using the hardcopy method cited above.
- Urgent priority TM deficiencies shall be reported by Naval message with transmission to Port Hueneme Division, Naval Surface Warfare Center (Code 310), Port Hueneme, CA. Local message handling procedures shall be used. The message shall identify each TM deficiency by TM identification number and title. This method shall be used in those instances where a TM deficiency constitutes an urgent problem, (i.e., involves a condition, which if not corrected, could result in injury to personnel, damage to the equipment, or jeopardy to the safety or success of the mission).

Complete instructions for TMDER generation and submission are detailed on the NSDSA website at:

<https://nsdsa.nmci.navy.mil/tmder/tmder.asp?lvl=1>.

1. SCOPE

1.1 This document contains the welding and allied processes (except brazing) and casting requirements including inspection for the fabrication, alteration, or repair of any item or component of machinery, piping, and pressure vessels in ships of the United States Navy.

1.2 Requirements for welding and inspection of HY and HSLA steel submarine structure and surface ship structure are contained in MIL-STD-1688, MIL-STD-1689 and MIL-STD-1681, as applicable.

1.3 Weldments made principally of sheet metal (such as electrical boxes; ventilation and air conditioning ducts; and protective covers for gears, belts, and chain drives) are excluded from the requirements of this document. Weldments of vents, overflows, and drains are also excluded.

1.4 This document contains both mandatory requirements and guidance information. The mandatory requirements, indicated by the words "shall" or "is required", are designed to serve as standards applicable to materials, workmanship, inspection, and quality control. Guidance information is indicated either by the word "should" or "may". Where specific approval by the Naval Sea Systems Command (NAVSEA) is required, it is so noted (see 1.6).

1.5 Reference in this document to a particular paragraph or section number shall include all applicable subparagraphs under that paragraph or section number. For example: The reference to paragraph 4.4 shall include subparagraphs 4.4.1 and 4.4.2.

1.6 Requirements subject to NAVSEA approval. Any requirements contained in this document specifically requiring NAVSEA approval shall be forwarded to Naval Sea Systems Command, 2531 Jefferson Davis Highway, Arlington, VA 22242-5160 via the authorized representative. Subcontractors shall submit such items to the contracting activity in accordance with the contract or purchase order. Contracting activities and authorized representative shall thoroughly review and make recommendations as to the acceptability of the requirement submitted.

1.7 Document precedence. Unless otherwise specified herein, in the event of conflict between this document and other documents, the following order of precedence shall apply:

- (a) Ship specifications for a particular ship or class, or Deep Diving General Overhaul Ship Specifications (DDGOSS), as appropriate (this includes plans and drawings).
- (b) Equipment or component specifications.
- (c) This document.
- (d) Other referenced documents.

S9074-AR-GIB-010/278

1.8 Upon acceptance by an activity, this issue of the document shall be used in its entirety. Previously approved deviations from earlier issues are not applicable unless approved for use with this issue.

1.9 For naval nuclear propulsion plant applications, the requirements of NAVSEA 250-1500-1 may be used in lieu of the requirements of this document provided:

- (a) Base and filler materials and welding processes normally allowed by NAVSEA 250-1500-1 are used, except, HY-80 and HY-100 welding shall be in accordance with this document.
- (b) All the requirements of NAVSEA 250-1500-1 are met.

2. REFERENCED DOCUMENTS

2.1 Government documents.

2.1.1 Specifications and standards. The following specifications and standards form a part of this document to the extent specified herein. Unless otherwise specified, the issues of these documents are those listed in the issue of the Department of Defense Index of Specifications and Standards (DoDISS) and supplement thereto, cited in the solicitation form a part of this document to the extent specified herein.

SPECIFICATIONS

FEDERAL

- | | |
|-------------|--|
| QQ-A-200 | - Aluminum Alloy, Bar, Rod, Shapes, Structural Shapes, Tube and Wire, Extruded: General Specification for. |
| QQ-A-200/1 | - Aluminum Alloy 3003, Bar, Rod, Shapes, Tube and Wire, Extruded. |
| QQ-A-200/4 | - Aluminum Alloy 5083, Bar, Rod, Shapes, Tube and Wire, Extruded. |
| QQ-A-200/5 | - Aluminum Alloy 5086, Bar, Rod, Shapes, Tube and Wire, Extruded. |
| QQ-A-200/6 | - Aluminum Alloy 5454, Bar, Rod, Shapes, Tube and Wire, Extruded. |
| QQ-A-200/7 | - Aluminum Alloy 5456, Bar, Rod, Shapes, Tube and Wire, Extruded. |
| QQ-A-225 | - Aluminum and Aluminum Alloy Bar, Rod, Wire, or Special Shapes; Rolled, Drawn, or Cold Finished: General Specification for. |
| QQ-A-225/1 | - Aluminum Alloy Bar, Rod, and Wire: Rolled, Drawn, or Cold Finished, 1100. |
| QQ-A-225/2 | - Aluminum Alloy Bar, Rod, and Wire: Rolled, Drawn, or Cold Finished, 3003. |
| QQ-A-225/7 | - Aluminum Alloy 5052, Bar, Rod, and Wire: Rolled, Drawn, or Cold Finished. |
| QQ-A-250 | - Aluminum and Aluminum Alloy Plate and Sheet: General Specification for. |
| QQ-A-250/1 | - Aluminum 1100, Plate and Sheet. |
| QQ-A-250/2 | - Aluminum Alloy 3003, Plate and Sheet. |
| QQ-A-250/6 | - Aluminum Alloy 5083, Plate and Sheet. |
| QQ-A-250/8 | - Aluminum Alloy 5052, Plate and Sheet. |
| QQ-A-250/10 | - Aluminum Alloy 5454, Plate and Sheet. |
| QQ-B-639 | - Brass, Naval: Flat Products (Plate, Bar, Sheet, and Strip). |
| QQ-C-390 | - Copper Alloy Castings (Including Cast Bar). |

FEDERAL (Continued)

- QQ-C-450 - Copper-Aluminum Alloy (Aluminum Bronze) Plate, Sheet, Strip, and Bar (Copper Alloy Numbers 606, 610, 613, 614, and 630).
- QQ-N-281 - Nickel-Copper Alloy Bar, Rod, Plate, Sheet, Strip, Wire, Forgings, and Structural and Special Shaped Sections.
- QQ-S-763 - Steel Bars, Wire, Shapes, and Forgings, Corrosion-Resisting.
- WW-P-404 - Pipe, Steel, (Seamless and Welded, Black and Zinc-Coated (Galvanized)).
- WW-T-700 - Tube, Aluminum and Aluminum Alloy, Drawn, Seamless, General Specification for.
- WW-T-700/1 - Tube, Aluminum, Drawn, Seamless, 1100.
- WW-T-700/2 - Tube, Aluminum, Alloy, Drawn, Seamless, 3003.
- WW-T-700/5 - Tube, Aluminum Alloy, Drawn, Seamless, 5086.

MILITARY

- MIL-T-1368 - Tube and Pipe, Nickel-Copper Alloy, Seamless and Welded.
- MIL-T-3595 - Tubing, Phosphor Bronze: (CDA No. 510) Round, Seamless.
- MIL-T-6736 - Tubing, Chrome-Molybdenum, 4130 Steel, Seamless and Welded, Aircraft Quality.
- MIL-W-6858 - Welding, Resistance: Spot and Seam.
- MIL-T-8504 - Tubing, Steel, Corrosion-Resistant (304), Aero-space Vehicle Hydraulic Systems, Annealed, Seamless and Welded.
- MIL-T-9046 - Titanium and Titanium Alloy, Sheet, Strip and Plate.
- MIL-T-9047 - Titanium and Titanium Alloy Bars (Rolled or Forged) and Reforging Stock, Aircraft Quality.
- MIL-T-15005 - Tubes, 70-30 and 90-10 Copper Nickel Alloy, Condenser and Heat Exchanger.
- MIL-C-15726 - Copper-Nickel Alloy, Rod, Flat Products (Flat Wire, Strip, Sheet, Bar, and Plate) and Forgings.
- MIL-S-16216 - Steel Plate, Alloy, Structural, High Yield Strength (HY-80 and HY-100).
- MIL-T-16286 - Tube, Steel, Seamless, Marine Boiler Application.
- MIL-T-16420 - Tube, Copper-Nickel Alloy, Seamless and Welded (Copper Alloy Numbers 715 and 706).
- MIL-R-17131 - Rods and Powders, Welding, Surfacing.
- MIL-N-17163 - Nickel-Copper Alloy, Wrought: (55-60 Percent Nickel) Low Permeability.
- MIL-I-17563 - Impregnants for Aluminum, Copper, Iron, Magnesium, and Zinc Alloy Castings.

MILITARY (Continued)

- MIL-S-18728 - Steel Plate, Sheet and Strip, Alloy 8630, Aircraft Quality.
- MIL-S-18729 - Steel Plate, Sheet, and Strip, Alloy 4130, Aircraft Quality.
- MIL-E-19933 - Electrodes and Rods - Welding, Bare, Chromium and Chromium-Nickel Steels.
- MIL-F-20236 - Fittings, Tube and Pipe, Butt-Welding, 300 P.S.I. and 775°F. Maximum.
- MIL-F-20670 - Flanges, Pipe, Carbon Steel, 150 P.S.I., W.S.P. (for Naval Shipboard Use).
- MIL-A-21180 - Aluminum-Alloy Castings, High Strength.
- MIL-E-21562 - Electrodes and Rods - Welding, Bare, Nickel Alloy.
- MIL-S-21952 - Steel (HY-80 and HY-100) Bars, Alloy.
- MIL-E-22200 - Electrodes, Welding, Covered: General Specification for.
- MIL-E-22200/1 - Electrodes, Welding, Mineral Covered, Iron-Powder, Low-Hydrogen Medium and High Tensile Steel, As Welded or Stress-Relieved Weld Application.
- MIL-E-22200/2 - Electrodes, Welding, Covered (Austenitic Chromium-Nickel Steel).
- MIL-E-22200/3 - Electrodes, Welding, Covered: Nickel Base Alloy; and Cobalt Base Alloy.
- MIL-E-22200/4 - Electrodes, Welding, Covered, Copper-Nickel Alloy.
- MIL-E-22200/5 - Electrodes, Welding, Mineral Covered, Iron-Powder, Low-Hydrogen, Low-Alloy Steel for Hardening and Tempering Heat Treatment Applications Only.
- MIL-E-22200/6 - Electrodes, Welding, Mineral Covered, Low Hydrogen, Medium and High Tensile Steel.
- MIL-E-22200/7 - Electrodes, Welding, Covered, Molybdenum Alloy Steel Application.
- MIL-E-22200/8 - Electrodes, Welding, Covered, Low-Hydrogen, and Iron Powder Low-Hydrogen, Chromium-Molybdenum Alloy Steel and Corrosion Resisting Steel.
- MIL-E-22200/10 - Electrodes, Welding, Mineral Covered, Iron-Powder, Low-Hydrogen Medium, High Tensile and Higher-Strength Low Alloy Steels.
- MIL-S-22698 - Steel Plate and Shapes, Weldable Ordinary Strength and Higher Strength: Hull Structural.
- MIL-S-23008 - Steel Castings, Alloy, High Yield Strength (HY-80 and HY-100).
- MIL-S-23009 - Steel Forgings, Alloy, High Yield Strength (HY-80 and HY-100).
- MIL-S-23193 - Steel, Corrosion Resistant Castings.

MILITARY (Continued)

- MIL-S-23194
- MIL-S-23195
- MIL-S-23196
- MIL-T-23226
- MIL-T-23227
- MIL-N-23228
- MIL-N-23229
- MIL-S-23284
- MIL-I-23413
- MIL-F-23467
- MIL-P-23508
- MIL-F-23509
- MIL-T-23520
- MIL-E-23765
- MIL-E-23765/1
- MIL-E-23765/2
- MIL-E-23765/3
- MIL-E-23765/4
- MIL-S-24093
- MIL-N-24106
- MIL-L-24128
- MIL-S-24238
- MIL-N-24271
- MIL-P-24338
- MIL-F-24339
- MIL-F-24342
- Steel Forgings, Carbon and Alloy.
- Steel Bars and Forgings, Corrosion Resistant.
- Steel Plate, Sheet and Strip, Corrosion Resistant.
- Tube and Pipe, Corrosion-Resistant Steel, Seamless.
- Tube and Pipe, Nickel Chromium Iron Alloy.
- Nickel-Chromium-Iron Alloy Plate, Sheet and Strip, Air Melted or Vacuum Remelted.
- Nickel-Chromium-Iron Alloy Bars and Forgings.
- Steel Forgings, Carbon and Alloy, for Shafts, Sleeves, Couplings, and Stocks (Rudders and Diving Planes):
- Inserts, Welding, Filler Material, Coiled and Solid Rings.
- Fitting and Flanges, Wrought, Seamless, Butt and Socket Welding, Austenitic Corrosion-Resistant Steel.
- Plating, Tin-Cadmium (Electrodeposited).
- Fittings and Flanges, Wrought, Seamless, Butt and Socket Welding, Nickel Copper Alloy.
- Tube and Pipe, Nickel-Copper Alloy, Seamless Air Melted.
- Electrodes and Rods - Welding, Bare, Solid and Alloyed Cored, General Specification for.
- Electrodes and Rods - Welding, Bare, Solid and Alloy Cored, Ordinary Strength and Low Alloy Steel.
- Electrodes and Rods; Welding, Bare, Solid, or Alloyed Cored, Low Alloy Steel.
- Electrodes, Welding, Bare, Copper and Copper Alloy.
- Electrodes-Welding, Bare, Solid; and Fluxes, Submerged Arc Welding, Carbon and Low Alloy Steels.
- Steel Forgings, Carbon and Alloy Heat Treated.
- Nickel-Copper Alloy Bars, Rods, and Forgings.
- Low Carbon Chromium Steel Bars, Rods, and Forgings.
- Steel Plate Carbon and Low Alloy.
- Nickel-Chromium-Iron Alloy Castings.
- Pipe, Carbon Steel, Seamless.
- Fittings and Flanges, Wrought, Seamless, Butt and Socket Welding Carbon Steel.
- Fitting and Flange, Wrought, Seamless, Butt and Socket Welding, 70-30 Copper Nickel Alloy.

MILITARY (Continued)

- MIL-E-24355 - Electrodes, Welding, Bare, Solid, Nickel-Manganese-Chromium-Molybdenum Alloy Steel for Producing HY-130 Weldments for As-Welded Applications.
- MIL-S-24371 - Steel Plate, Alloy, Structural, High Yield Strength (HY-130).
- MIL-E-24403 - Electrodes - Welding, Flux Cored, General Specifications for.
- MIL-E-24403/1 - Electrodes - Welding, Flux Cored, Ordinary Strength and Low Alloy Steel.
- MIL-E-24403/2 - Electrodes - Welding, Flux Cored, Low Alloy Steel.
- MIL-S-24451 - Steel Heat Treated Heads, Alloy Structural, High Yield Strength (HY-80 and HY-100).
- MIL-B-24480 - Bronze, Nickel-Aluminum (UNS No. C95800) Castings, for Seawater Service.
- MIL-C-24615 - Castings, Nickel-Chromium-Molybdenum-Columbium Alloy.
- MIL-S-24645 - Steel Plate, Sheet, or Coil, Age-Hardening Alloy, Structural, High Yield Strength (HSLA-80).
- DOD-F-24669/1 - Forgings and Forging Stock, Steel (Carbon and Alloy) Blooms, Bars, Billets and Slabs. (Metric)
- DOD-F-24669/2 - Forgings and Forging Stock, Steel Bars and Billets - Chromium-Molybdenum Alloy. (Metric)
- DOD-F-24669/6 - Forgings and Forging Stock, Steel Bars and Billets, Corrosion Resisting; for Reforging. (Metric)
- DOD-F-24669/7 - Forgings and Forging Stock, Steel Bars and Billets, Corrosion Resisting; Naval Steam Turbine Parts Use. (Metric)
- MIL-F-24669/8 - Forgings and Forging Stock, Steel for Integral Steam Turbine Rotors.
- MIL-N-24687 - Nickel-Chromium-Molybdenum-Iron-Columbium Alloy Bars and Forgings
- MIL-P-24691/1 - Pipe and Tube, Carbon Steel, Stainless.
- MIL-P-24691/2 - Pipe and Tube, Chromium-Molybdenum Steel, Seamless.
- MIL-P-24691/3 - Pipe and Tube, Corrosion-Resistant, Stainless Steel, Seamless or Welded.
- MIL-C-24707/1 - Castings, Ferrous, for Machinery and Structural Applications.
- MIL-C-24707/2 - Castings, for Pressure Containing Parts Suitable for High Temperature Service.
- MIL-C-24707/3 - Castings, Ferrous, Corrosion-Resistant, Austenitic, Chromium-Nickel.

MILITARY (Continued)

- MIL-C-24707/6 - Castings, Ferrous, Chromium Steel, for Pressure-Containing Parts Suitable for High Temperature Service.
- MIL-C-24723 - Castings, Nickel-Copper Alloy.
- MIL-H-81200 - Heat Treatment of Titanium and Titanium Alloys.

STANDARDS

MILITARY

- MIL-STD-22 - Welded Joint Design.
- MIL-STD-248 - Welded and Brazing Procedure and Performance Qualification.
- MIL-STD-271 - Nondestructive Testing Requirements for Metals.
- MIL-STD-276 - Impregnation of Porous Nonferrous Metal Castings.
- MIL-STD-438 - Schedule of Piping, Valves, Fittings, and Associated Piping Components for Submarine Service.
- MIL-STD-777 - Schedule of Piping, Valves, Fittings, and Associated Piping Components for Naval Surface Ships.
- MIL-STD-1627 - Bending of Pipe or Tube for Ship Piping Systems.
- MIL-STD-1628 - Fillet Weld Size, Strength, and Efficiency Determination.
- MIL-STD-1681 - Fabrication, Welding, and Inspection of HY-130 Submarine Applications.
- MIL-STD-1687 - Thermal Spray Processes for Naval Ship Machinery and Ordnance Applications.
- MIL-STD-1688 - Fabrication, Welding, and Inspection of HY80/100 Submarine Applications.
- MIL-STD-1689 - Fabrication, Welding, and Inspection of Ships Structure.
- MIL-STD-2035 - Nondestructive Testing Acceptance Criteria.
- MIL-STD-2191 - Repair Welding, Weld Cladding, Straightening and Cold Rolling of Main Propulsion Shafting.
- DDO-STD-2138 - Metal Sprayed Coating Systems for Corrosion Protection Aboard Naval Ships. (Metric)

2.1.2 Other Government publications. The following other Government publications form a part of this document to the extent specified herein.

PUBLICATIONS

NAVAL SEA SYSTEMS COMMAND (NAVSEA)

- | | |
|-------------------|---|
| 0900-LP-001-7000 | - Fabrication and Inspection of Brazed Piping Systems. |
| 0951-LP-031-8010 | - Repair and Overhaul, Main Boilers, 1200 PSI Steam Propulsion Plant. |
| 0951-LP-038-6030 | - 1200 PSI Pressure Fired Boiler and Supercharger, Vol. 3, Repair and Overhaul. |
| 392-0755 | - Seal Welding Manual. |
| 0910-LP-331-5300 | - Repair and Overhaul Main Propulsion Boilers. |
| NAVSEA 250-1500-1 | - Welding Standard. |

(Copies of specifications, standards, and publications required by contractors in connection with specific acquisition functions should be obtained from the contracting activity or, as directed by the contracting officer.)

2.2 Other publications. The following documents form a part of this document to the extent specified herein. Unless otherwise specified, the issues of the documents which are DoD adopted shall be those listed in the issue of the DoDISS specified in the solicitation. Unless otherwise specified, the issues of documents not listed in the DoDISS are issues of the documents cited in the solicitation.

AMERICAN SOCIETY FOR TESTING AND MATERIALS (ASTM)

- | | |
|-------|--|
| A 167 | - Standard Specification for Stainless and Heat Resisting Chromium - Nickel Steel Plate |
| A 176 | - Standard Specification for Stainless and Heat-Resisting Chromium Steel Plate, Sheet, and Strip. (DoD adopted) |
| A 178 | - Standard Specification for Electrical-Resistance-Welded Carbon Steel and Carbon-Manganese Steel Boiler Tubes |
| A 182 | - Standard Specification for Forged or Rolled Alloy-Steel Pipe Flanges, Forged Fittings, and Valves and Parts for High-Temperature Service. (DoD adopted) |
| A 213 | - Standard Specification for Seamless Ferritic and Austenitic Alloy-Steel Boiler, Superheater, and Heat-Exchanger Tubes. |
| A 216 | - Standard Specification for Steel Castings, Carbon, Suitable for Fusion Welding, for High-Temperature Service (DoD adopted) |
| A 217 | - Standard Specification for Steel Castings, Martensitic Stainless and Alloy, for Pressure-Containing Parts Suitable for High-Temperature Service. (DoD adopted) |
| A 234 | - Standard Specification for Pipe Fittings of Wrought Carbon Steel and Alloy Steel for Moderate and Elevated Temperatures. (DoD adopted) |

- A 240 - Standard Specification for Heat-Resisting Chromium and Chromium-Nickel Stainless Steel Plate, Sheet, and Strip for Pressure Vessels. (DoD adopted)
- A 276 - Standard Specification for Stainless and Heat Resisting Steel Bars and Shapes.
- A 302 - Standard Specification for Pressure Vessel Plates, Alloy Steel, Manganese-Molybdenum and Manganese-Molybdenum-Nickel. (DoD adopted)
- A 336 - Standard Specification for Steel Forgings, Alloy, for Pressure and High-Temperature Parts.
- A 487 - Standard Specification for Steel Castings Suitable for Pressure Service.
- A 494 - Standard Specification for Castings, Nickel and Nickel Alloy.
- A 515 - Standard Specification for Pressure Vessel Plates, Carbon Steel, for Intermediate- and Higher-Temperature Service. (DoD adopted)
- A 516 - Standard Specification for Pressure Vessel Plates, Carbon Steel, for Moderate- and Lower-Temperature Service. (DoD adopted)
- A 537 - Standard Specification for Pressure Vessel Plates, Heat-Treated, Carbon-Manganese-Silicon Steel. (DoD adopted)
- A 743 - Standard Specification for Castings, Iron-Chromium, Iron-Chromium-Nickel, Nickel-Base, Corrosion-Resistant, for General Application. (DoD adopted)
- A 744 - Standard Specification for Castings, Iron-Chromium-Nickel, Nickel-Base, Corrosion Resistant, for Severe Service. (DoD adopted)
- A 757 - Standard Specification for Steel Castings, Ferritic and Martensitic Steel, for Pressure-Containing and Other Applications, for Low-Temperature Service.
- B 21 - Standard Specification for Naval Brass Rod, Bar, and Shapes. (DoD adopted)
- B 26 - Standard Specification for Aluminum-Alloy Sand Castings. (DoD adopted)
- B 98 - Standard Specification for Copper-Silicon Alloy Rod, Bar, and Shapes. (DoD adopted)
- B 124 - Standard Specification for Copper and Copper-Alloy Forging Rod, Bar, and Shapes. (DoD adopted)
- B 138 - Standard Specification for Manganese Bronze Rod, Bar, and Shapes. (DoD adopted)
- B 139 - Standard Specification for Phosphor Bronze Rod, Bar, and Shapes. (DoD adopted)
- B 150 - Standard Specification for Aluminum Bronze Rod, Bar, and Shapes. (DoD adopted)
- B 152 - Standard Specification for Copper Sheet, Strip, Plate, and Rolled Bar. (DoD adopted)

AMERICAN SOCIETY FOR TESTING AND MATERIALS (ASTM) (Continued)

- B 166 - Standard Specification for Nickel-Chromium-Iron Alloys (UNS N06600 and N06690) Rod, Bar, and Wire. (DoD adopted)
- B 169 - Standard Specification for Aluminum Bronze Plate, Sheet, Strip, and Rolled Bar. (DoD adopted)
- B 209 - Standard Specification for Aluminum and Aluminum-Alloy Sheet and Plate. (DoD adopted)
- B 265 - Standard Specification for Titanium and Titanium Alloy Strip, Sheet, and Plate.
- B 337 - Standard Specification for Seamless and Welded Titanium and Titanium Alloy Pipe.
- B 338 - Standard Specification for Seamless and Welded Titanium and Titanium Alloy Tubes for Condensers and Heat Exchangers.
- B 348 - Standard Specification for Titanium and Titanium Alloy Bars and Billets.
- B 363 - Standard Specification for Seamless and Welded Unalloyed Titanium and Titanium Alloy Welding Fittings.
- B 367 - Standard Specification for Titanium and Titanium Alloy Castings.
- B 369 - Standard Specification for Copper-Nickel Alloy Castings. (DoD adopted)
- B 381 - Standard Specification for Titanium and Titanium Alloy Forgings.
- B 443 - Standard Specification for Nickel-Chromium-Molybdenum-Columbium Alloy (UNS N06625) Plate, Sheet, and Strip.
- B 444 - Standard Specification for Nickel-Chromium-Molybdenum-Columbium Alloys (UNS N06625) Pipe and Tube.
- B 446 - Standard Specification for Nickel-Chromium-Molybdenum-Columbium Alloy (UNS N06625) Rod and Bar.
- B 564 - Standard Specification for Nickel Alloy Forgings. (DoD adopted)
- B 574 - Standard Specification for Low-Carbon Nickel-Molybdenum-Chromium Alloy Rod.
- B 575 - Standard Specification for Low-Carbon Nickel-Molybdenum-Chromium Alloy Plate, Sheet and Strip.
- B 622 - Standard Specification for Seamless Nickel and Nickel Cobalt Alloy Pipe and Tube.
- E 38 - Standard Methods for Chemical Analysis of Nickel-Chromium and Nickel-Chromium-Iron Alloys.
- E 155 - Standard Reference Radiographs for Inspection of Aluminum and Magnesium Castings.
- E 186 - Standard Reference Radiographs for Heavy-Walled (2 to 4-1/2-in. (51 to 114-mm)) Steel Castings. (DoD adopted)
- E 192 - Standard Reference Radiographs of Investment Steel Castings for Aerospace Applications. (DoD adopted)
- E 272 - Standard Reference Radiographs for High-Strength Copper-Base and Nickel-Copper Alloy Castings.

AMERICAN SOCIETY FOR TESTING AND MATERIALS (ASTM) (Continued)

- E 280 - Standard Reference Radiographs for Heavy-Walled (4-1/2 to 12-in. (114 to 305-mm)) Steel Castings. (DoD adopted)
- E 310 - Standard Reference Radiographs for Tin Bronze Castings.
- E 446 - Standard Reference Radiographs for Steel Castings up to 2 in. (51 mm) in Thickness. (DoD adopted)

(Application for copies should be addressed to the American Society for Testing and Materials, 1916 Race Street, Philadelphia, PA 19103.)

AMERICAN WELDING SOCIETY (AWS)

- A2.4 - Symbols for Welding and Nondestructive Testing Including Brazing. (DoD adopted)
- A3.0 - Welding Terms and Definitions Including Terms for Brazing, Soldering, Thermal Spraying, and Thermal Cutting. (DoD adopted)
- A5.01 - Filler Metal Procurement Guidelines.
- A5.1 - Specification for Covered Carbon Steel Arc Welding Electrodes. (DoD adopted)
- A5.2 - Specification for Iron and Steel Oxyfuel Gas Welding Rods. (DoD adopted)
- A5.4 - Specification for Covered Corrosion-Resisting Chromium and Chromium-Nickel Steel Welding Electrodes. (DoD adopted)
- A5.5 - Specification for Low Alloy Steel Covered Arc Welding Electrodes. (DoD adopted)
- A5.6 - Specification for Covered Copper and Copper Alloy Arc Welding Electrodes. (DoD adopted)
- A5.7 - Specification for Copper and Copper Alloy Bare Welding Rods and Electrodes. (DoD adopted)
- A5.8 - Specification for Filler Metals for Brazing and Braze Welding.
- A5.9 - Specification for Corrosion Resisting Chromium and Chromium-Nickel Steel Bare and Composite Metal Cored and Stranded Welding Electrodes and Welding Rods. (DoD adopted)
- A5.10 - Specification for Aluminum and Aluminum Alloy Bare Welding Rods and Electrodes. (DoD adopted)
- A5.11 - Specification for Nickel and Nickel Alloy Covered Welding Electrodes.
- A5.13 - Specification for Solid Surfacing Welding Rods and Electrodes. (DoD adopted)
- A5.14 - Specification for Nickel and Nickel Alloy Bare Welding Rods and Electrodes.
- A5.16 - Specification for Titanium and Titanium Alloy Bare Welding Rods and Electrodes. (DoD adopted)
- A5.23 - Specification for Low Alloy Steel Electrodes and Fluxes for Submerged Arc Welding. (DoD adopted)
- A5.27 - Specification for Covered Copper and Copper Alloy Gas Welding Electrodes. (DoD adopted)
- A5.28 - Specification for Low Alloy Steel Filler Metals for Gas Shielded Arc Welding. (DoD adopted)

S9074-AR-GIB-010/278

C4.1-G - Oxygen Cutting Surface Roughness Gauge.

(Application for copies should be addressed to the American Welding Society, Inc., 550 NW LeJeune Road, P.O. Box 351040, Miami, FL 33135.)

SOCIETY OF AUTOMOTIVE ENGINEERS (SAE)

AMS 6530 - Steel Tubing, Seamless 0.50Cr - 0.55Ni - 0.20Mo (0.28 - 0.33C) (SAE 8630). (DoD adopted)

(Application for copies should be addressed to Society of Automotive Engineers, 400 Commonwealth Drive, Warrendale, PA 15096.)

MANUFACTURERS STANDARDIZATION SOCIETY OF THE VALVE AND FITTINGS INDUSTRY, INC.

SP-55 - Quality Standard for Steel Castings for Valves, Flanges, and Fittings; and Other Piping Components (Visual Method).

(Application for copies should be addressed to the Manufacturers Standardization Society of the Valve and Fittings Industry, 127 Park Street, N.E., Vienna, Va 22180.)

(Nongovernment standards are generally available for reference from libraries. They are also distributed among nongovernment standards bodies and using Federal agencies.)

3. GENERAL REQUIREMENTS

3.1 Responsibility. Each activity that accomplishes work in accordance with this document shall be familiar with its provisions and referenced specifications to the extent that they apply to the work being performed.

3.2 Engineering drawings. Drawings shall indicate essential fabrication details. Weld joints shall be identified by symbols in accordance with AWS A2.4 and joint design selection shall be in accordance with section 9. Nondestructive tests for welded joints shall be identified by symbols in accordance with AWS A2.4 except that single symbol PT may be used in lieu of DPT (dye penetrant) or FPT (fluorescent penetrant).

3.2.1 Referencing this document. Drawings shall carry a note stating that welding and inspection shall be in accordance with this document and give the applicable welding class, except those drawings related to components for which inspection requirements are covered by sections 14 and 15.

3.3 Nomenclature and definitions. Welding nomenclature and definitions used in the preparation of drawings, welding procedure specifications, and correspondence related to welding shall be accordance with AWS A3.0.

3.3.1 Definitions. The following definitions are applicable to this document:

3.3.1.1 Activity. Activity refers to all sites of an organization under the same quality assurance management and using the same quality assurance plan performing work to which this document is applicable.

3.3.1.2 Approved (approval). Approval refers to when the item under consideration has been accepted by NAVSEA or its authorized representatives.

3.3.1.3 Arc-strike. An arc strike is any inadvertent heat affected zone or change in the contour of the finished weld or base metal resulting from an arc or heat generated by the passage of electrical current between the surface of the finished weld or base metal and a current source, e.g. welding electrode or MT prod.

3.3.1.4 Authorized representative. Authorized representative is any Government representative specifically authorized to approve equipment, material, or procedures within the scope of this document for NAVSEA. They are as follows:

- (a) For Government shipyards: The delegated representative of the shipyard commander.
- (b) For commercial shipyards: The delegated representative of the Supervisor of Shipbuilding, Conversion, and Repair (SUPSHIP) or the American Bureau of Shipping when specified in the ship's specifications for a particular ship. This includes all applicable areas in the shipyard and applicable items furnished to the shipyard by subcontractors.

- (c) For Government purchase items (other than Government shipyards): The delegated representative of the Commanding Officer, Naval Ship Systems Engineering Station (NAVSES), Philadelphia.
- (d) When delegated by (a), (b), or (c) above, the representative of Defense Contract Administration Services Management Area (DCASMA).
- (e) Technical representative specifically authorized by NAVSEA.

3.3.1.5 Diving life support piping systems. Diving life support piping systems are piping systems for breathing gases (delivery and exhaust) for divers.

3.3.1.6 Dissimilar metal welds. Dissimilar metal welds are welds between two metals which differ sufficiently in metallurgical and physical properties to require special consideration in welding qualification and inspection. Welds made by either direct joining of the dissimilar metals or by use of weld deposited buttering are considered dissimilar metal welds.

3.3.1.7 Essential elements. "Essential elements" is defined as the essential elements specified in MIL-STD-248.

3.3.1.8 Fabrication welds. Fabrication welds are welds required to fabricate a weldment or welded system. These welds include designed weld joints; weld buildups; overlay cladding for corrosion resistance, hardfacing for wear resistance; and weld deposited buttering.

3.3.1.9 Government inspector. Government inspector is a Government official who is charged with the responsibility for assuring that the materials, processes, fabrication techniques, inspections, tests, and testing personnel meet specification and contractual requirements. In this regard, he shall be the authorized representative or the following:

- (a) When delegated by the authorized representative, the DCASMA inspector.
- (b) For forces afloat: The Squadron Commander or his delegated representative.
- (c) For Naval repair facilities: The commanding officer or his delegated representative.

3.3.1.10 Lethal fluids. Lethal fluids are poisonous gases or liquids of such nature that a very small amount of the gas or vapor of the liquid mixed or unmixed with air is dangerous to human life when inhaled. For purposes of piping system classification, lethal includes substances of this nature which are stored under pressure or which may generate a pressure if stored in a closed vessel. Some such substances are hydrocyanic acid, carbonyl chloride, cyanogen chloride gas, and xylyl bromide. For the piping system classification purposes of this document, ammonia, chlorofluorocarbon refrigerants, natural or manufactured gas, any liquefied petroleum

gas (such as propane, butane, or butadiene) and vapors of any other petroleum products are not classified as lethal substances.

3.3.1.11 Organization inspector. The organization inspector shall be the inspector of a contractor, Naval shipyard, or Government agency who has been authorized by the organization to inspect and accept or reject materials and workmanship and to witness tests and validate test data. In process, visual inspectors can be production personnel.

3.3.1.12 Pressure containing. Pressure containing shall refer to that area of a component or weld which prevents contained liquid or gas from escaping.

3.3.1.13 Procedure qualification. A welding procedure qualification is an action by which test assemblies are prepared in accordance with a proposed procedure and evaluated either by destructive or nondestructive tests or both.

3.3.1.14 Qualified. The term "qualified" means that the item under consideration has been approved as required by this document.

3.3.1.15 Seal welds. Seal welds are welds provided for a fluid containment function only, as in a closure where strength is provided by a separate device. This definition does not apply to boiler, economizer, and superheater tube-to-header "seal" welds.

3.3.1.16 Tube-to-header "seal" welds. Tube-to-header "seal" welds are welds between various types of boiler tubes and their respective headers (or drums), such as economizer headers, superheater headers, and so forth. These welds are located on the interior of the header (or drum). Integrity of the tube-to-header connection is provided by a combination of welding and rolling the tube. Tube-to-header "seal" welds shall be performed in accordance with NAVSEA 0951-LP-031-8010 in addition to the requirements specified herein.

3.3.1.17 Welding-deposited buttering. Welding-deposited buttering is weld metal deposited on base metal prior to completing the weld to permit the final portion of a dissimilar metal weld to be completed as a similar metal weld.

3.3.1.18 Weld-deposited overlay cladding. Weld-deposited overlay cladding is weld metal which is deposited for the purpose of corrosion protection only.

3.3.1.19 Weld-deposited hard surfacing. Weld deposited hard surfacing is weld metal which is deposited for the purpose of providing wear resistance.

3.3.1.20 Welded fabrication or weldment. Welded fabrication or weldment is any assembly where component parts are joined by welding.

3.3.1.21 Welding procedure. Welding procedure is written instructions designed for use in production welding and repair welding, delineating all the essential elements and guidance to produce acceptable welds.

3.3.1.22 Straw (color). Straw is a color occurring on titanium welds from slight contamination whose hue ranges from light gold through brass.

3.3.2 Classification. The following classifications are applicable to this document:

(a) Machinery, class M.

- (1) Class M-1. Class M-1 machinery includes welds in moving parts, such as gears, rotors, impellers and shafting (except propulsion shafting and rudder stocks) that transmit torque or thrust. Welding of propulsion shafting and rudder stocks shall conform to MIL-STD-2191.
- (2) Class M-2. Class M-2 machinery includes welds in stationary non-pressurized assemblies or structures, such as sub-bases for turbines, engines, motors, and pumps.

Each of these sub-classes shall be further categorized as to criticality in accordance with the following:

a. Category A. Safety and mission of the ship.

Safety. Includes machinery forming part of, or directly supporting, watertight integrity or machinery the failure of which would cause loss of ship control, propulsion, or weight handling equipment.

Mission. Machinery essential to the mission of the ship, such as weapon and fire control systems, navigation communication systems, and major auxiliary support systems.

b. Category B. Normal operation of the ship. Machinery essential to the normal operation of the ship.

c. Category C. Non-essential items. Includes parts of components in categories A and B having welded joints that do not transmit the principal operating load or support any type of pressure boundary.

(b) Piping, class P. Class P piping includes all piping, tubing, and fittings for conveying fluids. Classes P-1, P-2, and P-LT apply to welded systems. Class P-3 applies to brazed systems.

- (1) Class P-1. Class P-1 includes fabrication welds for design pressures exceeding 300 pounds per square inch (lb/in²) or design temperatures exceeding 650 degrees Fahrenheit (°F), or both, such as steam lines, hydraulic systems, boiler generating tubes, superheater and economizer elements, other pressure retaining tubes and piping (excluding nozzle or root connections to pressure vessels, which are covered under the appropriate classification), and all piping systems for conveying oxygen, gasoline, and lethal gases or liquids regardless of pressure and temperature. This class also includes fabrication welds

in piping systems which transmit oxygen, helium, mixed gases, air, water and exhaust of diving life support systems. Also included are any structural welds made to the internal or external surfaces of a fluid boundary subject to system pressure but which do not form a part of the fluid boundary. This includes any weld made to a weld deposited pad or cladding on the fluid boundary as well as the weld deposited pad or cladding beneath the weld itself. This does not include cladding other than cladding beneath the weld nor does it include welds which join clips, nameplates, insulation supports, or other nonstructural members to the fluid boundary. Specifically excluded are pipe joints meeting the classification criteria of class P-LT.

- (2) Class P-2. Class P-2 includes fabrication welds for design pressures and design temperatures not exceeding 300 lb/in² and 650 °F. Also included are fabrication welds in all open ended vent, drain and steam escape piping that has no isolation capability from its origin to its terminus regardless of the design temperature or pressure. Specifically excluded are pipe joints meeting the classification criteria of class P-LT.
 - (3) Class P-LT. Class P-LT includes fabrication welds for all piping of design pressures greater than 50 lb/in² and service temperatures of minus 20 °F and below.
 - (4) Class P-3. Class P-3 piping includes all brazed piping of unlimited pressures and 425 °F maximum design temperature. Fabrication and inspection of brazed piping systems shall be in accordance with NAVSEA 0900-LP-001-7000.
- (c) Pressure vessels and tanks, class A. Class A pressure vessels and tanks include the fabrication welds for parts of drums, tanks, or closed receptacles (including nozzle attachments) and valves which are designed to contain gases or liquids. This includes all feed tanks, lubricating oil storage tanks, and similar vessels which contain only the static head of the obtained liquid. It does not include tubing or piping that joins to the pressure vessel, which are subject to the requirements of class P piping. Valves to be installed in class P-1 piping system shall be fabricated and inspected in accordance with class A-2 pressure vessel requirements. Valves to be installed in other classes of piping systems shall be fabricated and inspected in accordance with the appropriate pressure vessel category as determined by design temperatures and pressures.
- (1) Class A-F. Class A-F includes fabrication welds for fired and unfired pressure vessels for all pressures and temperatures that are specifically designed for a finite fatigue life and, as a consequence, are required to undergo low cycle fatigue evaluations. Also included are any structural welds made to the internal or external surfaces of a fluid boundary subject to system pressure but

which do not form a part of the fluid boundary. This includes any weld made to a weld deposited pad or cladding on the fluid boundary as well as the weld deposited pad or cladding beneath the weld itself. This does not include cladding other than cladding beneath the weld nor does it include welds which join clips, nameplates, insulation supports, or other nonstructural members to the fluid boundary. Examples of pressure vessels in this class are all submergence pressure sea water cooled submarine heat exchangers and catapult steam receivers.

- (2) Class A-1. Class A-1 includes fabrication welds for fired pressure vessels, drums, and headers, in which steam is generated by the application of heat resulting from the combustion of fuel. It includes economizer and superheater headers. Specifically excluded are welds of pressure vessels meeting the classification criteria of classes A-2, A-3, A-4, or A-LT.
 - (3) Class A-2. Class A-2 consists of fabrication welds for unfired pressure vessels with design pressures or design temperatures exceeding 400 lb/in² or 650°F, respectively, for liquids at 300°F or higher, and for lethal gases and liquids at any temperature or pressure. Class A-2 also includes valves to be installed in class P-1 piping systems. Specifically excluded are welds of pressure vessels meeting the classification criteria of classes A-3, A-4, or A-LT.
 - (4) Class A-3. Class A-3 consists of fabrication welds for unfired pressure vessels with design pressures and design temperatures not exceeding 400 lb/in² and 650°F. Specifically excluded are welds of pressure vessels meeting the classification criteria of classes A-4 or A-LT.
 - (5) Class A-4. Class A-4 consists of fabrication welds for unfired pressure vessels with design pressures or design temperatures not exceeding 150 lb/in² and 450°F, including tanks subject only to the static head or the liquid contained. Specifically excluded are welds for pressure vessels meeting the classification criteria of class A-LT.
 - (6) Class A-LT. Class A-LT consists of fabrication welds for pressure vessels with design pressures greater than 50 lb/in² and service temperatures of minus 20°F and below.
- (d) Steam turbines, Class T. Class T steam turbines consist of fabrication welds for steam turbine components or parts (except piping) listed in table XXI. Since steam turbines consist of components subject to service conditions varying from high pressure to vacuum, class T is broken down as follows:

S9074-AR-GIB-010/278

- (1) Class T-1. Class T-1 consists of fabrication welds subject to operating pressures of 300 lb/in² or greater.
- (2) Class T-2. Class T-2 consists of fabrication welds subject to less than 300 lb/in² and fabrication welds in structural members.

4. QUALITY ASSURANCE AND QUALIFICATION PROVISIONS

4.1 Quality assurance.

4.1.1 General. This section contains the minimum requirements for assuring that components and systems meet inspection criteria specified in this document.

4.1.2 Material control. The activity is responsible to inspect material upon receipt to assure that it meets the specified mechanical and chemical requirements. Receipt inspection shall consist of, but not be restricted to, comparing the contractor's data with the specified requirements and sampling of the received material to establish a reasonable confidence in the reliability of the contractor's data. An identification system shall be established and maintained which includes the specification number and type or grade of the material. Periodic internal audits of the inventories, stocking facilities, and shops shall be performed to assure that materials are correctly identified. A system shall be established that requires visual verification prior to fabrication or installation to ensure that the identification of the material corresponds to that specified by the applicable drawing or document.

4.1.2.1 Quality assurance system. Each organization shall maintain a quality assurance system adequate to assure NAVSEA or its authorized representative, or the Government inspector that all of the requirements of this document have been and are continuously being met. Written procedures shall be prepared to assign responsibility and provide accountability for performing work and inspections.

4.1.2.2 Material Control - special requirements for MIL-120 and MIL-140 series filler materials. In addition to the requirements of 4.1.2, all MIL-120 and MIL-140 series filler materials shall be receipt inspected in accordance with the requirements of paragraph 6.5.1 except for MIL-STD-2191 applications (shafting repairs).

4.1.3 Records - applicable to classes A-F, A-1, A-2, A-3, A-LT, P-1, P-LT, H-1, and T-1. The quality control system shall include preparing and maintaining written records of at least the following items for each welded joint that undergoes nondestructive test (NDT) inspection, excluding hydrostatic tests, of weld classes A-F, A-1, A-2, A-3, A-LT, P-1, P-LT, H-1, and T-1. The records shall be traceable to the hardware or weld joint and from the hardware or weld joint to the records.

- (a) Joint identification
- (b) Joint design.
- (c) Base material type (including heat or lot or level I identification when required by the applicable system or component specification).
- (d) Filler material type (including heat or lot or level I identification for titanium materials, and when required by the applicable system or component specification for other materials).

- (e) Fit-up.
- (f) Welding procedure identification.
- (g) Heat treatments (including preheat, interpass, and post-weld heat treatment temperatures).
- (h) Welder identification.
- (i) NDT methods and results.
- (j) Disposition of welds.
- (k) Cycles of repairs to weld.
- (l) Inspection procedures.
- (m) NDT personnel identification.

- NOTES: 1. See sections 10 and 13 for inspection and record requirements for base material weld repairs.
2. For the weld classes listed above, a signed inspection record is required for each weld or weld repair in S-51, S-52, and S-53 base metals. The record shall include the following additional information:
- a. Verifications that the weld joint was cleaned before welding and that inert shielding and purge gas of the required dew point was used.
 - b. Identification of the welders for each pass. Results of the in process inspection of 7.10.2 and the responsible welder's (or inspector's) signature and date.
 - c. Identification of any pass that failed the visual inspection and how that pass was repaired.
 - d. Postweld heat parameters, if applicable.

4.1.3.1 Record form. A record form shall be prepared prior to the commencement of the operation which it covers. Operations shall be recorded prior to the commencement of the next operation. Items (i), (j), (l), and (m) of 4.1.3 shall be signed or stamped by the activity's qualified NDT personnel and dated except that 5X magnification visual inspections of weld root layers may be performed by qualified production personnel. All other items shall be signed and dated by production personnel or inspection personnel. When a specific item on the record form is not applicable, the letters "N.A." (Not Applicable) shall be entered. Final acceptance of a weldment shall not be permitted until all items on the record formats are marked as specified above.

4.1.3.2 Maintenance of records. Unless otherwise specified, all required records shall be maintained by the activity and be available to NAVSEA or its authorized representative throughout the life of the contract and for 3 years after delivery. At the expiration of the record retention period, NAVSEA or its

authorized representatives shall be given a written notification. Disposition of records shall be as agreed upon by NAVSEA and the contractor.

4.1.4 Nonconformance. If NAVSEA or the Government inspector has evidence that the requirements of this document are not being met, they can suspend upon written notification the use of any questionable materials, equipment, procedures, personnel, and so forth, on work covered by this document until conformance with the requirements of this document is judged satisfactory by NAVSEA or the Government inspector.

4.2 Welding qualification (procedure, welder, and operator requirements).

4.2.1 Welding procedure. Prior to production welding, welding procedures in accordance with the requirements of MIL-STD-248 and this document shall be prepared by the activity. Welding procedures shall assure conformance with this document and shall be submitted for information when procedure qualification test data are submitted to the authorized representative for approval (see 4.2.1.2) or whenever the welding procedures are revised. Procedures qualified in accordance with NAVSEA 392-0755 may be used for welding of seal welds without separate qualification in accordance with MIL-STD-248.

4.2.1.1 Conditions governing welding procedure qualification tests. Welding procedure qualification tests are required where fabrication drawings or specifications invoke this document, except qualification tests are not mandatory where both of the following conditions are met.

- (a) Either classes M-1 category C, M-2 category C, A-4, P-2 (except for joint designs welded from one side only with no backing), or T-2 weldments are involved, and the base materials being joined are of the same "S-number" group (except S-11A, S-11B, S-11C, S-51 to S-53) listed in table I (or a comparable ASME P-number group, if approved) and the corresponding filler materials listed in table III are used with the following manual or semi-automatic processes.
- (1) Shielded metal-arc.
 - (2) Gas tungsten-arc.
 - (3) Gas metal-arc.
 - (4) Flux core.
 - (5) Submerged-arc.
 - (6) Oxyacetylene where group S-1 materials 3/16 inch or less in thickness are joined.
- (b) Fabrication entails welding of assemblies, the possible failure of which is remote and would not result in danger to ship personnel, shipboard components or equipment, or ship structure. Items in this category

include but are not limited to name plates, galley equipment, furniture, fixtures, and tack welds.

4.2.1.2 Approval of procedure qualification data. Procedure qualification test data obtained in accordance with MIL-STD-248 shall be submitted for approval. Approval shall be obtained prior to production welding. The welding procedure upon which the qualification test assemblies are made shall also be submitted for review (see 4.2.1).

4.2.1.3 Welding procedure qualification - special requirements for MIL-120 and MIL-140 series filler materials. Welding procedure qualification requirements for MIL-120 and MIL-140 series filler materials shall be as approved by NAVSEA, except for MIL-STD-2191 applications (shafting repairs).

4.3 Welder, tack welder, and welding operator qualification. Welders, tack welders, and welding machine operators shall be qualified in accordance with MIL-STD-248.

4.3.1 For welding of internal tube to header (or drum) welds in boiler components the following shall apply:

- (a) Welders who have not performed internal tube-to-header welding within 6 months shall perform one tube-to-header weld in accordance with MIL-STD-248 except that the subject test assembly need only be subjected to visual inspection of the root pass and visual and PT inspection of the finished weld.
- (b) Any reject will require full recertification in accordance with MIL-STD-248.
- (c) Certification of completion of this test or identification of performed work with the preceding 6-month period shall be added to MIL-STD-278 weld joint history records.

4.3.2 Titanium welders and welding operators qualified outside of a chamber shall be trained in chamber operation prior to the initial performance of chamber welding.

4.3.3 Welder and welding operator performance qualification - special requirements for MIL-120 and MIL-140 series filler materials. Welder and welding operator performance qualification requirements for MIL-120 and MIL-140 series filler materials shall be as approved by NAVSEA, except for MIL-STD-2191 applications (shafting repairs).

4.4 Welding equipment. Welding equipment in the hands of qualified welders, tack welders, and welding operators shall produce welds that meet the applicable acceptance criteria under production conditions.

4.4.1 If the authorized representative doubts the capability of any particular item of welding equipment, he shall for a stated cause require it to be tested in

accordance with the applicable equipment specification or joint welding procedure tests. If the requirements cannot be met, the equipment shall not be used for production work until satisfactory repairs or adjustments have been made.

4.4.2 The fabricator shall devise, direct, and supervise the testing of any item of equipment (see 4.4.1) and shall bear the expense of conducting these tests. The fabricator shall notify the Government and arrange a time and place for conducting the tests so the Government inspector may be present.

4.5 NDT personnel. NDT procedures and personnel shall be qualified in accordance with MIL-STD-271. In addition, inspectors working with S-51, S-52, and S-53 materials shall be qualified to perform the color inspection required for these materials.

4.6 Approval for fabrication and welding of titanium and titanium alloys. See 30. in appendix A.

5. MATERIALS

5.1 General. This section contains requirements for base and filler materials fabricated under this document.

5.2 General requirements. Base materials fabricated under this document and filler materials used in welding shall be in accordance with tables I and II, respectively, unless otherwise approved in accordance with 5.2.1.

TABLE I. Grouping of base materials (welding). 1/

Letter no.	Applicable document	Class or type
S-1	Carbon Steel	
	ASTM A 178	Grade A (tube) Grade C
	ASTM A 216	WCB
	ASTM A 515	Grade 55 (plate) Grade 60 (plate) Grade 65 (plate) Grade 70 (plate)
	ASTM A 516	Grade 70 (plate)
	MW-P-404	Pipe seamless and welded
	MIL-S-15083	Grade 70-36 (cast) Grade 65-35 (cast) Grade CW (cast) Grade B (cast)
	MIL-T-16286	Class a (tube seamless) Class g (tube seamless)
	MIL-T-17188	Tubes welded
	MIL-S-24093	Forgings
	MIL-T-20157	Type E (tube and pipe)
	MIL-S-24412	Grade HT (shape)
	MIL-F-20236	Flanges. pipe
	MIL-F-20670	Flanges. pipe
	MIL-S-22698	Plate and shapes
	MIL-S-23194	Composition C (forgings)
	MIL-S-23284	Class 3 Class 4
MIL-S-24238	Composition C (plate)	

See footnotes at end of table.

TABLE I. Grouping of base materials (welding). 1/ - Continued

Letter no.	Applicable document	Class or type
S-1	MIL-P-24338	Pipe
	MIL-F-24339	Fittings and flanges
	ASTM A 234	WPB (Fittings)
	MIL-P-24691/1 MIL-C-24707/1	Grade B (tube and pipe) ASTM A757, grade A1Q (castings) grade A20 ASTM A216, grade WCA (castings) grade WCB grade WCC
S-2	Quenched and tempered carbon steel	
	ASTM A 537	Class 2
S-3	Carbon molybdenum steel	
	MIL-S-870	CMo (cast)
	MIL-S-872	CMo class a (forgings) CMo class b (forgings)
	MIL-T-16286	CMo class d (tube)
	MIL-S-16974	CrNi type 8620 (bar and forgings)
	MIL-T-20155	CMo (tube and pipe)
	DOD-F-24669/1	CrNi type 8620 (bar and forgings)
	MIL-P-24707/2	ASTM A217 grade WC1 (castings)
S-3A	Alloy steels (Cr content not to exceed 3/4 percent, total alloy not to exceed 2 percent).	
	ASTM A 302	MnMo, grade B (plate)
	MIL-S-23194	Comp A, types Ia, Ib, and II
	MIL-S-24238	NiMnMo, comp A (plate)
S-4	Alloy steels (Cr content 3/4 percent - 2 percent, total alloy content 2-3/4 percent maximum)	
	AMS 6530	CrNiMo (tube)
	MIL-T-6736	CrMo, type 4130 (tube)
	MIL-S-15164	CrMo class I (casting)

See footnotes at end of table.

TABLE I. Grouping of base materials (welding). 1/ - Continued

Letter no.	Applicable document	Class or type
S-4	ASTM A 182	F11
	ASTM A 213	Grade T11 (tube)
	MIL-S-16974	CrMo type 4130 (bar)
	MIL-T-18165	CrMo class 1 (tube and pipe)
	MIL-S-18410	CrMo class a (forgings)
	MIL-S-18728	CrNiMo type 8630 (plate)
	MIL-S-18729	CrMo type 4130 (plate)
	DOD-F-24669/2	CrMo. composition F-11 (forgings)
	MIL-C-24707/2	ASTM. A217. grade WC6 (casting)
S-5	Alloy steels (total alloy content 10 percent maximum)	
	ASTM A 182	F22
	ASTM A 213	T22
	MIL-S-860	CrMoV. grade F (forgings)
	MIL-S-1E464	CrMo class 2 (casting)
	MIL-T-16286	CrMo class e (tube)
	MIL-T-18165	CrMo class 2 (tube and pipe)
	MIL-S-18410	CrMo class b (forging)
	DOD-F-24669/2	CrMo. composition F-22 (forgings)
	MIL-F-24669/8	CrMoV. grade F (forgings)
	MIL-P-24691/2	CrMo. grade P-22 (tube and pipe)
	MIL-C-24707/2	ASTM A217. grade WC9 (casting)
	ASTM A 336	CrMo class F5 (bar and forgings)
	S-6	High alloy steels (martensitic)
MIL-L-24128		403 (bars, rods, forgings)
QQ-S-763		403 (bars, rods, forgings) 410 414 420
ASTM A 176 ASTM A 240		410 and 410S (plate, sheet, strip)
MIL-S-861		403 (bars) 410

See footnotes at end of table.

TABLE I. Grouping of base materials (welding). 1/ - Continued

Letter no.	Applicable document	Class or type
S-6	MIL-S-862	403 (bars) 410 414 420
	MIL-S-16993	12 percent Cr class 1 (casting) 12 percent Cr class 2 (casting)
	DOD-F-24669/6	403 (bars) 410 414 420
	DOD-F-24669/7	403 (bars) 410
	MIL-C-24707/6	ASTM A217, grade CA-15 (casting) ASTM A487, grade CA-15M class A
S-6A	ASTM A 182 ASTM A 487	F6NM (forgings) CA6NM (castings)
S-7	High alloy steels (Ferritic)	
	QQ-S-763	405 (bar, shapes, forgings) 430
	ASTM A 176 ASTM A 240	405 and 430 (plate, sheet, strip)
S-8	High alloy steels (austenitic)	
	QQ-S-763	304 (bars, shapes, forgings) 304L 309 310 316 316L 321 347
	ASTM A 167	309 (plate, sheet, strip) 310

See footnotes at end of table.

TABLE I. Grouping of base materials (welding). 1/ - Continued

Letter no.	Applicable document	Class or type
S-8	ASTM A 240	304 (plate, sheet, strip) 304L 309 310 316 316L 321 347
	MIL-S-867	Class I (castings) Class II Class III
	MIL-P-1144	304 (pipe) 304L 316 316L 321 347
	MIL-T-8504	304 (tubing)
	MIL-T-16286	Class c (tube seamless)
	MIL-S-17509	Class I, II, III
	MIL-S-23193	Composition A 19-9 Composition B 19-10 Composition C 19-10
	MIL-S-23195	304 (bar and forgings) 304L 347 348
	MIL-S-23196	304 (plate, sheet, strip) 304L 347 348
	MIL-T-23226	304 (tube and pipe) 304L 347 348
	MIL-F-23467	304 (fittings and flanges) 304L 347 348

See footnotes at end of table.

TABLE I. Grouping of base materials (welding). 1/ - Continued

Letter no.	Applicable document	Class or type
S-8	MIL-P-24691/3	304 (pipe) 304L 316 316L 321 347
	MIL-C-24707/3	ASTM A744, grade CF-8 (castings) ASTM A744, grade CF-8C ASTM A744, grade CF-8M
	ASTM A 744	CN-7M, CN-7MS (castings)
S-10H	High Alloy Steel (Duplex Stainless)	
	ASTM A 240	Alloy 2205, UNS 31803 (plate) 5/
	ASTM A 276	Alloy 2205, UNS 31803 (bar) 5/
S-11A 4/	Quenched and tempered alloy steels	
	MIL-S-16216	HY-80 (plate) HY-100
	MIL-S-20154	Special treatment steel (plate)
	MIL-S-23008	HY-80 (castings) HY-100
	MIL-S-21952	HY-80 (bars) HY-100
	MIL-S-23009	HY-80 (forgings)
	MIL-S-23284	Class 1 Class 2
	MIL-L-24451	HY-80 (heads) HY-100
S-11B 4/	Quenched and tempered alloy steels	
	MIL-S-24371	HY-130 (plate, castings, bars, forgings, extrusions and shapes)
S-11C 4/	Age hardening alloy steel	
	MIL-S-24645	HSLA-80 (plate and sheet)
S-21	Aluminum and aluminum base alloys	
	QQ-A-200/1	3003 (extruded bars, rods)
	QQ-A-225/1	1100 (bars, rods)
	QQ-A-225/2	3003 (bars, rods)

See footnotes at end of table.

TABLE I. Grouping of base materials (welding). 1/ - Continued

Letter no.	Applicable document	Class or type
S-21	QQ-A-250/1	2200 (plate)
	QQ-A-250/2	3003 (plate and sheet)
	MW-T-700/1	1100
	MW-T-700/2	3003
S-22	Aluminum and aluminum base alloys	
	QQ-A-200/6	5454 (extruded bar, rods)
	QQ-A-225/7	5052 (bar, rod)
	QQ-A-250/8	5052 (plate)
	QQ-A-250/10	5454
S-25	Aluminum and aluminum base alloys	
	QQ-A-200/5	5086 (extruded bar, rod)
	QQ-A-200/4	5083
	QQ-A-200/7	5456
	QQ-A-250/6	5083
	ASTM B 209 ASTM B 209	5086 5456
	MW-T-700/5	5086 (seamless tube)
S-26	Aluminum and aluminum base alloys	
	ASTM B26	Alloy A03550 (castings) Alloy A03560 Alloy A05140 Alloy A24430
	QQ-A-601	B443 514 355 356
	MIL-A-21180	A 356 (castings)

See footnotes at end of table.

TABLE I. Grouping of base materials (welding). I/ - Continued

Letter no.	Applicable document	Class or type
S-31	Copper and copper base alloys	
	ASTM B152	Alloy C10200 (plate, bar) Alloy C10400 Alloy C10500 Alloy C11000 Alloy C11300 Alloy C11400 Alloy C12200 Alloy C12300
	QQ-C-576	99.9 Cu (plate, bar)
S-32	Brass	
	ASTM B21 ASTM B124	Alloy C46400 (rod/bar/shapes) Alloy C46400 (forging rod/bar/shapes)
	QQ-C-390	Alloy C85700 (casting)
	QQ-B-637	Naval brass (alloy 464) (rod, bar, and forging)
	QQ-B-639	Naval brass alloy (rod, bar, and forging) Alloy 462 Alloy 464
S-33	Silicon bronze	
	ASTM B98 ASTM B124	Alloy C65500 (rod/bar/shapes) Alloy C65500 (forging rod/bar/shapes)
	QQ-C-390	Alloy C87200 (castings)
	QQ-C-591	Alloy 655 (rod, shapes, flats)
S-34	Copper nickel	
	ASTM B369	Alloy C96200 (castings) Alloy C96400
	MIL-T-15005	70/30 (tube) 90/10
	MIL-C-15726	70/30 (plate, bar, rod) 90/10
	MIL-T-16420	70/30 (tube) 90/10
	MIL-C-20159	C96400 C96200

See footnotes at end of table.

TABLE I. Grouping of base materials (welding). 1/ - Continued

Letter no.	Applicable document	Class or type
S-34	MIL-P-24342	70/30 (fittings and flanges)
S-35	Aluminum bronze	
	ASTM B124 ASTM B150	Alloy C64200 (forging rod, bar, and shapes) Alloy C60600 (rod, bar, and shapes) Alloy C61400 Alloy C64200
	ASTM B169	Alloy C61400 (plate, sheet, strip, and rolled bar)
	QQ-C-390	Alloy C95200 (castings) Alloy C95400
	QQ-C-450	Alloy 606 (plate, bar) Alloy 612, 614
	QQ-C-465	(Rod, bar, plate, strip, flats, and forgings) Alloy C60600 Alloy C61400 Alloy C64200
	MIL-C-15345	Alloy 13 (castings) Alloy 15
S-36A	Nickel-aluminum bronze	
	ASTM B124 ASTM B150	Alloy C63000 (forging rod/bar/shapes) Alloy C63000 (rod/bar/shapes)
	QQ-C-390	Alloy C95500 (castings)
	QQ-C-465	Alloy C63000 (bar, rod, plate, strip, forging)
	MIL-C-15345	Alloy 14 (castings) Alloy 15
	MIL-B-24480	Castings
S-36B	Manganese-nickel-aluminum bronze	
	MIL-B-21230	Alloy 2 (castings)
S-37A	Manganese bronze	
	ASTM B138	Alloy C67000 (rod, bar, and shapes) Alloy C67500
	QQ-B-728	Class A Class B

See footnotes at end of table.

TABLE I. Grouping of base materials (welding). 1/ - Continued

Letter no.	Applicable document	Class or type
S-37A	QQ-C-390	Alloy C86100 Alloy C86200 Alloy C86300 Alloy C86400 Alloy C86500
S-37B	Nickel manganese bronze	
	QQ-C-390	Alloy C86800
S-38	Tin bronze	
	MIL-B-16541	Castings
	QQ-C-390	Alloy C90300 (castings) Alloy C90500 Alloy C90700 Alloy C92200 Alloy C92300 Alloy C92500 Alloy C94700 Alloy C94800
S-39	Phosphor bronze	
	ASTM B139	Alloy C51000 (rod, bar, and shapes) Alloy C52400
	QQ-B-750	Composition A Composition D
	MIL-T-3595	
S-42	Nickel-copper	
	A494	Comp. M-30C (casting)
	QQ-N-281	NiCu, class A (bar, plate, rod, forging) Class B
	MIL-N-24106	NiCu, class A (bar, rods, forgings)
	QQ-N-288	NiCuSiCb, composition E (casting)
	MIL-T-1368	NiCu (tubing)
	MIL-T-23520	NiCu (tube and pipe)
	MIL-C-15845	NiCuSiCb, alloy 19 (casting)
	MIL-N-17163	NiCu (bar, rod, plate, forging, and so forth)
	MIL-F-23509	Fittings and flanges

See footnotes at end of table.

TABLE I. Grouping of base materials (welding). 1/ - Continued

Letter no.	Applicable document	Class or type
S-42	MIL-C-24723	Comp. M-30C (casting)
S-43	Nickel-chromium-iron and nickel-chromium-molybdenum-columbium	
	MIL-F-23508	Fittings and flanges
	ASTM B 166	Rod and bar
	ASTM B 564	Forgings
	MIL-N-23227	Tube and pipe
	MIL-N-23228	Condition A (plate)
	MIL-N-23229	Condition A (hot worked and annealed)
	MIL-N-24271	Castings
	MIL-N-24687	NiCrMoCb (bars, forgings)
	ASTM B 443	UNS N06625 (plate)
	ASTM B 444	UNS N06625 (pipe and tube)
	ASTM B 446	UNS N06625 (bar and rod)
	MIL-C-24615	NiCrMoCb (casting)
2/ 3/ S-44	Nickel-Molybdenum-Chromium Alloy	
	ASTM B 574	UNS N10276 (rod)
	ASTM B 575	UNS N10276 (plate, sheet, strip)
	ASTM B 622	UNS N10276 (pipe, tube)
3/ S-51	Titanium and titanium alloys	
	MIL-T-9046	CP-3 (sheet, strip, plate) CP-4 (sheet, strip, plate)
	ASTM B 265	Grade 7 (sheet, strip, plate)
	ASTM B 337	Grade 1 (pipe) Grade 2 (pipe) Grade 7 (pipe)
	ASTM B 338	Grade 1 (tubing) Grade 2 (tubing) Grade 7 (tubing)

See footnotes at end of table.

TABLE I. Grouping of base materials (welding). 1/ - Continued

Letter no.	Applicable document	Class or type
3/ S-51	ASTM B 348	Grade 1 (bars, billets) Grade 2 (bars, billets) Grade 7 (bars, billets)
	ASTM B 363	WPT 1 (fittings) WPT 2 (fittings) WPT 7 (fittings)
	ASTM B 381	Grade F-1 (forgings) Grade F-2 (forgings)
3/ S-52	Titanium and titanium base alloys	
	MIL-T-9046	CP-1 (sheet, strip, plate) CP-2 (sheet, strip, plate)
	MIL-T-9047	CP-70 (bars, reforging stock)
	ASTM B 337	Grade 3 (pipe)
	ASTM B 338	Grade 3 (tubing)
	ASTM B 363	WPT 3 (fittings)
	ASTM B 367	Grade C-2 (castings) Grade C-3 (castings)
3/ S-53	Titanium and titanium base alloys	
	MIL-T-9046	AB-1 (sheet, strip, plate) AB-2 (sheet, strip, plate)
	MIL-T-9047	6Al-4V (bars, forgings) 6Al-4V (ELI) (bars, forgings)
	ASTM B 265	Grade 5 (sheet, strip, plate)
	ASTM B 367	Grade-5 (castings)
	ASTM B 381	Grade F-5 (forgings)

- 1/ If material of similar chemistry and mechanical properties not listed under an "S" group is to be used, it may be considered as a part of a group upon approval.
- 2/ Approval of welding procedure qualifications for these materials shall be obtained from NAVSEA.
- 3/ The use of titanium or Nickel-Molybdenum-Chromium Alloy for applications covered by this document requires specific approval from NAVSEA.

4/ See 6.5.

5/ With additional requirements for toughness, composition, heat treatment and other items as approved by NAVSEA.

TABLE II. Grouping of filler materials (welding). 1/ 6/

Group	Applicable document	Filler material type 5/
A-1A	Low and medium carbon steel (covered electrodes)	
	AWS A5.1	6010 6011 6012 6013 6020 6027 7024
A-1B	Low and medium carbon steel (bare rod)	
	AWS A5.2	R60 R65
A-2A	Carbon and low alloy steel (covered electrode)	
	MIL-E-22200/1	MIL-7018
	MIL-E-22200/6	MIL-7015 MIL-7016
	MIL-E-22200/7	MIL-7010-A1 MIL-7011-A1 MIL-7018-A1 MIL-7020-A1
	MIL-E-22200/10	2/ MIL-7018M
A-2B	Carbon and low alloy steel (bare electrode, rod, and inserts)	
	MIL-E-23765/1	MIL-70S-1 MIL-70S-2 MIL-70S-3 MIL-70S-4 MIL-70S-5 MIL-70S-6
	MIL-I-23413 (inserts)	MIL-MS-1 MIL-MS-2
A-2C	Carbon and low alloy steel (bare electrode and flux)	
	MIL-E-23765/1	MIL-70S-7 (wire) 3/ MIL-70S-8 (wire) 3/ MIL-70S-9 (wire) MIL-70S-1 (wire) MIL-70S-2 (wire) MIL-70S-3 (wire) MIL-70S-4 (wire) MIL-70S-5 (wire) MIL-70S-6 (wire) MIL-70S-F (flux)

See footnotes at end of table.

TABLE II. Grouping of filler materials (welding). 1/ 6/ - Continued

Group	Applicable document	Filler material type 5/
	MIL-E-23765/4	MIL-F6A2-EL12 (wire and flux) MIL-F6A2-EM12K MIL-F7AZ-EM12K MIL-F7A2-EM12K
A-2D	Low alloy steel (flux cored electrodes)	
	4/ MIL-E-24403/1	MIL-70T-1 MIL-71T-1 MIL-70T-5 MIL-70T-6 MIL-70T-8 MIL-71T-8 MIL-71T-8A MIL-71T8-K6 MIL-71T8-Ni1
A-3A	Carbon and low alloy steel (low hydrogen covered electrodes)	
	MIL-E-22200/6	MIL-8015-C3 MIL-8016-C3 MIL-10015 MIL-10016
	MIL-E-22200/1	MIL-8018-C3
A-3B	Carbon and low alloy steel (bare electrode)	
	MIL-E-23765/2	MIL-80S-3
A-3C	Carbon and low alloy steel (bare electrode and flux)	
	MIL-E-23765/2	MIL-80S-1 (wire) MIL-80S-1F (flux) MIL-80S-2 (wire) MIL-80S-2F (flux)
A-3D	Carbon and low alloy steel (flux cored electrodes)	
	4/ MIL-E-24403/1	MIL-80T1-Ni1 MIL-80T1-Ni2 MIL-81T1-Ni1 MIL-81T1-Ni2
A-4A	Low alloy, high-yield steel (covered electrodes)	
	MIL-E-22200/5	MIL-10018-N1
A-5A 7/	Low alloy, high yield steel (covered electrode)	
	MIL-E-22200/1	MIL-9018-M MIL-10018-M MIL-11018-M
	MIL-E-22200/10	MIL-10018-M1 MIL-12018-M2

See footnotes at end of table.

TABLE II. Grouping of filler materials (welding). 1/ 6/ - Continued

Group	Applicable document	Filler material type 5/
A-5B 7/	Low alloy, high yield steel (bare electrode)	
	MIL-E-23765/2	MIL-100S-1 MIL-100S-2 MIL-120S-1
	MIL-E-24355	MIL-140S-1
A-5C 7/	Low alloy, high strength steel (bare electrode and flux)	
	MIL-E-23765/2	MIL-100S-1 (wire) MIL-100S-1F (flux) MIL-100S-2 (wire) MIL-100S-2F (flux) MIL-120S-1 (wire) MIL-120S-1F (flux)
A-5D 7/	Low alloy, high yield steel (flux cored electrode)	
	MIL-E-24403/2	MIL-100TC MIL-100TM MIL-100TS MIL-101TC MIL-101TM MIL-101TS MIL-110TC
A-6A	CrMo steel (1.0 to 2.5 percent Cr, 0.4 to 1.2 percent Mo) (covered electrode)	
	MIL-E-22200/8	MIL-80XX-B2 and -B2L MIL-90XX-B3 and -B3L
	AWS A5.5	E8018-B2 and -B2L E9018-B3 and -B3L
A-6B	CrMo steel (1.0 to 3.0 percent Cr, 0.4 to 1.2 percent Mo) (bare electrode, rod and insert)	
	MIL-I-23413	MIL-515 MIL-521
	AWS A5.28	ER80S-B2 and -B2L ER90S-B3 and -B3L
A-6C	CrMo Steel, (1.0 to 3.0 percent Cr, 0.45 to 1.10 percent Mo) (bare electrode and flux)	
	AWS A5.23	F8PX-EB2-B2HB F9PX-EB3-B3HB

See footnotes at end of table.

TABLE II. Grouping of filler materials (welding). 1/ 6/ - Continued

Group	Applicable document	Filler material type 5/
A-7A	CrMo steel (4.0-13.5 percent Cr, 0-5.0 percent Ni, 0.4-1.4 percent Mo) (covered electrode)	
A-7A-1	MIL-E-22200/8	MIL-502-XX MIL-502-XX-L MIL-505-XX
A-7A-2	MIL-E-22200/8	MIL-410-XX MIL-410 NiMo-XX
A-7B	CrMo steel (4.0-13.5 percent Cr, 0-5.0 percent Ni, 0.4-1.4 percent Mo) (bare electrode, rod, and inserts)	
A-7B-1	MIL-I-23413	MIL-505
A-7B-2	MIL-E-19933 AWS A5.9	MIL-410 ER410NiMo
A-7C	High alloy steel (ferritic) (chromium 15-18 percent) (covered electrode)	
	AWS A5.4	E430-XX
A-7D	High alloy steel (ferritic) (chromium 15-18 percent) (bare electrode and rod)	
	AWS A5.9	ER-430
A-8A	High alloy steel (austenitic) (covered electrode)	
	MIL-E-22200/2	MIL-16.8.2-XX MIL-308-XX MIL-308L-XX MIL-308HC-XX MIL-309L-XX MIL-309-XX MIL-309Cb-XX MIL-310-XX MIL-312-XX MIL-316-XX MIL-316L-XX MIL-317-XX MIL-318-XX MIL-330-XX MIL-347-XX MIL-347HC-XX MIL-349-XX
	AWS A5.4	E320-XX

See footnotes at end of table.

TABLE II. Grouping of filler materials (welding). 1/ 6/ - Continued

Group	Applicable document	Filler material type 5/
A-8B	High alloy steel (austenitic) (bare electrode rod and insert)	
	MIL-E-19933	MIL-308 MIL-308L MIL-308HC MIL-309 MIL-310 MIL-312 MIL-316 MIL-316L MIL-317 MIL-318 MIL-321 MIL-347
	AWS A5.9	ER309L ER320
	MIL-I-23413 (inserts)	MIL-308 MIL-308L MIL-310 MIL-312 MIL-316 MIL-316L MIL-348
A-9A	High alloy steel (duplex stainless) (covered electrode).	
	AWS A5.4 10/	E2209-15/16
A-9B	High alloy steel (duplex stainless) (bare electrode and rod)	
	AWS A5.2B 10/	ER2209
A-21B	Aluminum alloy (bare electrode, rod, and insert)	
	AWS A5.10	R1100
	AWS A5.10	ER1100
	MIL-I-23413 (insert)	MIL-1100
A-22B	Aluminum alloy (bare electrode, rod, and insert)	
	AWS A5.10	R5183 R5356 R5554 R5556 R5654
	AWS A5.10	ER5183 ER5356 ER5554 ER5556 ER5654

See footnotes at end of table.

TABLE II. Grouping of filler materials (welding). 1/ 6/ - Continued

Group	Applicable document	Filler material type 5/
A-22B	MIL-I-23413 (inserts)	MIL-5356
A-23B	Aluminum alloy (bare electrode, rod and insert)	
	AWS A5.10	ER-4043
A-24B	MIL-I-23413 (inserts)	MIL-4043
	Aluminum alloy (bare electrode and rod)	
A-31B	AWS A5.10	ER 2319
	Copper alloy (bare electrode and rod)	
A-32A	AWS A5.7	ERCu
	Copper alloy (silicon bronze covered electrode)	
A-32B	AWS A5.6	E-CuSi
	Copper alloy (silicon bronze bare electrode and rod)	
A-33A	MIL-E-23765/3	MIL-CuSi
	Copper tin alloy (covered electrode)	
A-33B	AWS A5.6	ECuSn-A ECuSn-C
	Copper tin alloy (phosphor bronze) (bare electrode and rod)	
A-34A	MIL-E-23765/3	MIL-CuSn-C
	Copper nickel (covered electrode)	
A-34B	MIL-E-22200/4	MIL-CuNi (70/30)
	Copper nickel (bare electrode, rod, and insert)	
	MIL-E-21562	MIL-EN67 MIL-RN67
A-35B	MIL-I-23413 (insert)	MIL-67
	Copper-zinc alloy (bare rod)	
	MIL-E-23765/3	MIL-CuSn-C
A-36B	AWS A 5.8	RBCuZn-B RBCuZn-C RBCuZn-D
	Copper aluminum alloy (aluminum bronze) (bare electrode and rod)	
	MIL-E-23765/3	MIL-CuAl-A2

See footnotes at end of table.

TABLE II. Grouping of filler materials (welding). 1/ 6/ - Continued

Group	Applicable document	Filler material type 5/
A-37A	Copper aluminum alloy (aluminum bronze) (covered electrode)	
	AWS A5.6	ECuA1-A2 ECuA1-B
	AWS A5.13	ECuA1-C ECuA1-D ECuA1-E
A-37B	Copper-aluminum-nickel alloys (NiAl and MnNiAl bronze) (bare electrode and rod)	
	MIL-E-23765/3	MIL-CuNiAl MIL-CuMnNiAl
A-38B	Surfacing alloys (bare rod)	
	MIL-R-17131	MIL-RNiCr-B MIL-RNiCr-C MIL-PNiCr-B-2 MIL-PNiCr-C-2
A-39A	Surfacing alloys (covered electrode)	
	AWSA5.13	ECoCr-A ECoCr-C
A-39B	Surfacing alloys (bare rod)	
	MIL-R-17131	MIL-RCoCr-A MIL-RCoCr-C MIL-PCoCr-E-1 MIL-PCoCr-E-2
A-41A	Nickel (covered electrode)	
	MIL-E-22200/3	MIL-4Ni1
A-41B	Nickel (bare electrode, rod, and insert)	
	MIL-E-21562	MIL-EN61 MIL-RN61
	MIL-I-23413 (insert)	MIL-61
A-42A	Nickel base alloys (covered electrodes)	
	MIL-E-22200/3	MIL-9Ni10
A-42B	Nickel base alloys (bare electrode, rod, and insert)	
	MIL-E-21562	MIL-EN60 MIL-RN60
	MIL-I-23413 (insert)	MIL-60

See footnotes at end of table.

TABLE II. Grouping of filler materials (welding). 1/ 6/ - Continued

Group	Applicable document	Filler material type 5/
A-43A	Nickel base alloys (covered electrode)	
	MIL-E-22200/3	MIL-1N12 MIL-3N12 MIL-4N12 MIL-4N1A MIL-8N12
A-43B	Nickel base alloys (bare electrode, rod and inserts)	
	MIL-E-21562	MIL-EN62 MIL-RN62 MIL-EN82 MIL-RN82 MIL-EN6A MIL-RN6A MIL-EN625 MIL-RN625
	MIL-I-23413	MIL-62 MIL-82
A-44A	Nickel-cobalt alloys (covered electrodes)	
	MIL-E-22200/3	MIL-3N1B MIL-3N1C MIL-4N1W MIL-3N1N MIL-3N1L
A-45A	Nickel-Molybdenum-Chromium Alloy (covered electrodes)	
	AWS A5.11	ENiCrMo-4 (UNS-WB0276) 8/
A-45B	Nickel-Molybdenum-Chromium Alloy (bare electrode and rod)	
	AWS A5.14	ERNiCrMo-4 (UNS-NI0276) 9/
A-51B	Titanium-unalloyed (bare electrode)	
	AWS A5.16	ERTi-1 ERTi-2 ERTi-3 ERTi-7
A-53B	Titanium base alloys (bare electrode)	
	AWS A5.16	ERTi-5 ERTi-5ELI

- 1/ If filler material of similar chemistry and mechanical properties is not listed under an A-group, it may be considered as a part of a group upon approval.
- 2/ To be also used for welding ordinary strength steel to HY-80 steel.
- 3/ To be used with neutral flux.

- 4/ Electrodes with an "HY" suffix are also suitable for welding ordinary or higher strength steel to HY-80 steel or to HY-100 steel.
- 5/ A filler material type containing an "X" in the designation allows various options; for example, "MIL-309-XX" permits "MIL-309-15 or -16".
- 6/ Use of AWS filler material shall require compliance with 5.2.1 where the same military specification filler material type exists. If there is no military specification filler material type, conformance testing of each lot of electrode shall be accomplished in accordance with AWS A5.01. As a minimum, schedule J shall be employed. Lot classification shall be in accordance with AWS A5.01 Class C3 for covered electrodes, Class S2 for bare solid electrodes and rods, brazing filler metal, and consumable inserts; Class T2 for flux cored electrodes and metal cored electrodes and rods; and Class F2 for fluxes for SAW and brazing. Test requirements shall be submitted for approval in accordance with 5.2.1.
- 7/ See paragraph 6.5.
- 8/ The covered electrodes shall conform to all the quality conformance requirements of MIL-1N12 specified in MIL-E-22000/3 but with tensile properties and chemical composition of E NiCrMo-4 as specified in AWS A5.11.
- 9/ The filler metal shall conform to all the quality conformance requirements for EN/RN625 specified in MIL-E-21562 but have a minimum tensile strength of 100 ksi, an elongation of 25 percent and a chemical composition of ER NiCrMo-4 as specified in AWS A5.14.
- 10/ With additional requirements for toughness, ferrite content and other items as approved by NAVSEA.

5.2.1 Material substitution approval. Unless otherwise covered in the Government equipment specifications, materials acquired in accordance with AMS, AWS, ASTM, or ASME standards (or approved substitution material list) may be used for materials listed in tables I and II subject to the following provision:

- (a) To ensure compliance to the governing material specification, quality assurance and inspection requirements shall be established by the contractor and submitted to NAVSEA or authorized representative for approval. After obtaining approval, the contractor shall invoke the requirements in purchase orders for materials or perform the required inspection upon receipt of material or prior to its use in fabrication.

5.2.2 Specification deviations. Unless otherwise covered in the Government specification, deviations from specification requirements of governing material specifications shall be submitted to NAVSEA or authorized representative for review and approval.

5.2.3 Exceptions. Approvals required by 5.2.1 and 5.2.2 will be granted only by NAVSEA when materials related to sections 13, 14, and 15 are involved.

5.3 Material inspection. In addition to the requirements of 4.1.2, material records shall be verified to assure conformance of the material with the applicable specifications. Verification shall be accomplished by checking mill or inspection reports against the applicable specification requirements and material marking, as applicable, against the material received. Additionally, for material supplied from a warehouse or jobber (not directly from the manufacturer), the user activity (construction) shall conduct periodic independent testing to establish reasonable confidence in the reliability of contractor test data in accordance with a written procedure. If the contractor's quality conformance inspection records are not available, the construction activity shall establish specification conformance of the material in accordance with a written procedure.

5.3.1 Material identification. The identification of the material shall be maintained to the point of initial fabrication in accordance with a written procedure. The identification of the material shall be visually verified at the point of initial fabrication as being the same material identification or an approved alternate material identification, as required by the installation plan.

5.3.2 Filler material inspection. Inspection test reports covering tests conducted by the manufacturer shall be verified by the contractor for conformance with specification requirements. If the manufacturer's quality conformance inspection records are not available, the construction activity shall establish specification conformance of the material.

6. WELDING REQUIREMENTS AND CONTROLS

6.1 General. This section contains the requirements or controls that are essential for ensuring satisfactory welds in machinery, piping, pressure vessels, and steam turbines hereinafter referred to as M, P, A, and T.

6.1.1 Gas metal-arc welding - short circuiting transfer (GMAW short arc) restriction. This process shall not be used unless approved otherwise for a specific application, on a case-by-case basis, by NAVSEA.

6.1.2 Non-structural welds such as name plates, clips and insulation supports on class P-1, P-LT, A-F, A-I, A-2, A-3, A-LT, T-1, and M-1 components shall be made by welders qualified for butt or fillet welds. These welds shall be inspected in accordance with section 10.

6.1.3 Autogenous welding shall not be used for S-10H materials.

6.2 Welding processes and filler materials. Acceptable welding processes and compatible filler materials are shown in table III. Specific filler materials for steam service applications shall be in accordance with 6.2.5.1. Processes and materials not listed in table III and material not in accordance with 6.2.5.1 shall be permitted where applicable welding procedure qualification data are approved by NAVSEA and authorized for the particular production applications. Aluminum alloys shall be welded only by the inert gas metal-arc and the inert gas tungsten arc processes. The root pass of S-8 piping welds in which the reverse side of the weld cannot be visually examined and is exposed to water shall be welded with a gas shielded welding process. Inert gas shielding is also required for S-51, S-52, and S-53 materials as required in 6.2.7.

6.2.1 Oxyacetylene restrictions. Except as permitted by 11.6, oxyacetylene or fuel gas welding processes shall not be used for welding on chromium-molybdenum (S-4, S-5), chromium alloy (S-6, S-7), chromium-nickel (S-8), quenched and tempered alloy steels (S-11), and aluminum or aluminum alloys (S-21, S-22, S-25 and S-26).

6.2.2 Class P material thickness limitation. The shielded metal arc process may be used for wall thickness of 0.109 inch or over when welded on board ship and 0.083 inch or over when welded in the shop. Other welding processes will be permitted for thinner walls on the basis of welding procedure qualification tests.

6.2.3 Covered electrodes for class P-1 carbon steel pipe. Class P-1 carbon steel pipe shall be welded with electrode types MIL-7018, MIL-7018M, MIL-7018-A1, MIL-7015 or MIL-7016 (A-2A) except when nominal wall thickness is 1/2 inch or less MIL-7010-A1 electrodes A-1A may be used.

6.2.4 Prohibited electrodes. Unless specifically approved, types MIL-6010, 6012 or 6013 electrodes of AWS A5.1 shall not be used for M, P, and A applications.

TABLE III. Welding filler material chart.

Base metal	Welding processes and compatible filler material 1/				Oxygen acetylene	Insert materials	Plasma arc
	S number group	Shielded metal-arc	Submerged arc	Gas shielded processes (gas metal-arc, gas tungsten arc, and flux cored)			
Carbon-steel	S-1	A-1A, A-2A, A-3A	A-2C 6/	A-2B, A-3B, A-2D	A-1B	A-2B	.
Quenched and tempered carbon-steel	S-2	A-2A, A-3A	A-2C A-3C	A-2B, A-3B, A-2D	.	A-2B	.
Alloy steel (C) < 3/4 percent	S-3 S-3A	A-2A 2/, A-3A, A-6A 2/ 3/	A-2C A-3C	A-2B, A-3B	.	A-2B	.
Alloy steel (Cr 3/4-2 percent)	S-4	A-6A 9/	A-6 C	A-6B	.	A-6B	.
High alloy steel (alloy not > 10 percent)	S-5	A-6A 9/ A-7A-1	A-6 C	A-6B	.	A-6B	.
High alloy steel (martensitic)	S-6 S-6A	A-7A-2 A-7A-2 10/	A-7B-2 5/ 11/, 12/ A-7B-2 5/ 10/, 12/	A-7B-2 11/ A-7B-2 10/	.	.	.
High alloy steel (ferritic)	S-7	A-7A-2
High alloy steel (austenitic)	S-8 7/	A-8A 7/	A-8B 5/	A-8B 7/	.	A-8B	.
High alloy steel (duplex)	S-10H	A-9A	.	A-9B	.	.	.
Quenched and tempered alloy steel	S-11 13/

See footnotes at end of table.

Original 50

S9074-AR-GIB-010/278

TABLE III. Welding filler material chart. - Continued

Base metal	Welding processes and compatible filler material 1/				Oxygen acetylene	Insert materials	Plasma arc
	S number group	Shielded metal-arc	Submerged arc	Gas shielded processes (gas metal-arc, gas tungsten arc, and flux cored)			
Aluminum and aluminum-base alloys	S-21	.	.	A-21B	.	A-21B	.
	S-22	.	.	A-22B	.	A-22B	.
	S-25	.	.	A-22B	.	A-22B	.
	S-26	.	.	A-23B, A-24B	.	A-22B	.
Copper and copper-base alloys	S-31	.	.	A-31B	.	.	.
	S-32	A-32A	.	A-32B	A-31B	.	.
	S-33	A-32A	.	A-32B	A-32B, A-35B	.	.
	S-34	A-34A	A-34B 5/	A-34B	A-32B	.	.
	S-35	A-37A	.	A-37B, A-36B	.	A-34B	.
	S-36A	A-37A 4/	.	A-37B	.	.	.
	S-36B	.	.	A-37B	.	.	.
	S-37A	A-37A	.	A-36B, A-37B	.	.	.
	S-37B	A-37A	.	A-36B, A-37B	A-35B	.	.
	S-38	.	.	A-32B	.	.	.
	S-39	.	.	A-33B	A-35B	.	.
	Nickel and nickel-base alloy	S-42	A-42A	A-42B 5/	A-42B	.	.
S-43		A-43A	A-43B 5/	A-43B	.	A-42B	.
Nickel-Molybdenum-Chromium alloy	S-44	A-45A	.	A-45B	.	A-43B	.
Hardsurfacing	.	A-39A 8/	.	A-38B, A-39B	.	A-45B	.
	.	.	.	A-38B, A-39B	A-38B, A-39B	.	A-38B
Titanium and titanium alloy	S-51	.	.	A-51B	.	.	A-39B
	S-52	.	.	A-51B	.	.	A-51B
	S-53	.	.	A-53B	.	.	A-51B
							A-53B

See footnotes at end of table.

Original 51

59074-AR-GIB-010/278

TABLE III. Welding filler material chart. - Continued

- 1/ This table is intended to assist in selecting filler material for the various welding processes (see table II to identify "A" numbers).
- 2/ Electrodes of MIL-E-22200/7 only.
- 3/ When joining S-3 materials whose minimum tensile requirements are 80,000 lb/in².
- 4/ Not to be used for welding of MIL-B-24480.
- 5/ When used with flux in accordance with qualified procedure.
- 6/ Filler material A-2B is permitted when used with flux in accordance with qualified procedure.
- 7/ For welding CN-7N or CN-7MS material, E-320 and ER-320 filler materials should be used for SMAW and GMAW/GTAW, respectively.
- 8/ Deposition technique must yield a surface hardness of R_c 35 minimum.
- 9/ See 6.2.5.1.1.
- 10/ Type 410 NiMo only.
- 11/ For 410 and 410S steel only.
- 12/ Where approved by NAVSEA for the specific application.
- 13/ See 6.5.

6.2.5 Selection of filler materials. Filler materials shall be selected for compatibility with the base material on the basis of chemical composition, mechanical properties, post weld heat treatment requirements, and component/system operating conditions and requirements. Tables II and III identify specifications in which guidelines may be found to assist in selecting compatible filler materials for more commonly used base materials.

6.2.5.1 Filler materials for steam service applications.

6.2.5.1.1 Ferritic and martensitic steel filler metals for the base materials commonly used in steam service applications shall be as follows:

Base material S-group No.	Filler metal A-group no.
For S-1 materials	- A-2A, A-2B, A-2D, A-1B, and A-1A (MIL-7010-A1 only as noted in 6.2.3)
For S-3 materials	- A-2A (MIL-7010-A1, 7011-A1, 7018-A1, and 7020-A1 only)
For S-3A materials	- A-3A, A-3B, A-3C
For S-4 materials	- A-6A (80XX-B2 and -B2L only) A-6B (MIL-515, ER80S-B2 and -B2L only) A-6C (FBPX-EB2-B2HB only)
For S-5 materials	- A-6A (90XX-B3 and -B3L only) A-6B (MIL-521, ER90S-B3 and -B3L only) A-6C (F9PX-EB3-B3HB only)
For S-6 and S-7 materials	- A-7A-2 or A-7B-2
For S-6A materials	- A-7A-2 (MIL-410-NiMo-XX only), A-7B-2

6.2.5.1.2 For welding of different combinations of the base materials as specified in 6.2.5.1.1, the welding filler metal shall be specified for either of the base materials involved except for covered electrodes, only the low hydrogen types XX-15, XX-16, and XX-18 shall be used with S-3A, S-4, S-5, S-6 and S-7 base materials.

6.2.5.1.3 For joining base materials under groups S-1, S-3, S-3A, S-4, S-5, S-6 and S-7 to base materials under group S-8, the following filler metals shall be used:

Nickel base alloys

A-43A (MIL-8N12 only)

A-43B (MIL-82, EN82, and RN82 only)

High alloy steel (austenitic)

A-8A (MIL-309-XX, MIL-309L-XX, MIL-309Cb-XX, and MIL-310-XX only)

A-8B (MIL-309, MIL-310, and ER309L only)

Where post weld heat treatment is required by component or equipment specifications, or where design service temperature exceeds 400°F, only the above listed A-43A or A-43B filler metals shall be used.

6.2.5.1.4 For surfacing applications to resist steam cutting, the filler metals specified in 6.2.5.1.3 may be used on base materials under groups S-1, S-3, S-3A, S-4, S-5, S-6 and S-7. Where subsequent post heat treatment of these base materials is required, only the MIL-8N12, EN-82, and RN82 filler metals shall be used.

6.2.5.1.5 For welding the dissimilar metal combinations of S-10H to S-11 or S-2 alloy steels, the electrode for shielded metal-arc welding shall be MIL-1N12 OF MIL-E-22200/3 and for gas metal-arc and gas tungsten-arc welding the filler metal shall be MIL-EN625 or MIL-RN625 of MIL-E-21562 as applicable.

6.2.6 Number of weld passes. Unless otherwise approved, no less than two layers shall be used for all pressure containing weld joints.

6.2.7 Weld back side shielding. Inner root surface of all consumable insert type welds and all full penetration butt welds not employing a backing ring shall be shielded by inert gas. Internal purge shall be continued until after completion of the third layer or a thickness of 3/16 inch, whichever is greater. This requirement does not apply to P-2 type weld joints in P-2 piping systems of materials other than S-21 through S-26, provided it can be demonstrated to the satisfaction of the authorized representative that the internal surface of the weld meets the visual requirements of MIL-STD-2035.

6.2.7.1 When welding in or to titanium or titanium alloys (including repair welding of base metal and welds) the weld area backside shall be shielded with inert gas unless the backside temperature is determined to remain less than 500°F. Shielding shall continue until completion of welding. Temperature shall be determined by checking actual backside surfaces during welding with pyrometers or other suitable means, or if the area is inaccessible for measurement, a mock-up of the weldment heat sink simulating worst case production conditions shall be welded. Temperature measurements shall be obtained from the mock-up weld backside area as necessary to demonstrate that temperatures will remain below 500°F during all production welding. A description of the mock-up and welding and temperature test results shall be maintained with the welding procedure qualification records.

6.2.8 Age hardenable alloys. Welding of age hardenable alloys is subject to NAVSEA approval.

6.3 Preheat and interpass temperatures. Preheat and interpass temperatures shall be as specified in tables IV and V unless otherwise approved by welding procedure qualification.

TABLE IV. Preheat and interpass temperature for welded ferrous alloys.

Material group number	Material identification	Minimum preheat temperature °F 1/. 2/. 3/	Maximum interpass temperature °F	Supplementary provisions for preheat and interpass temperature
S-1	Carbon steel	175	-	Where both carbon content in base metal is greater than 0.30 percent and thickness exceeds 1 inch
		60	-	For all other S-1 materials
S-2	Quenched and tempered carbon steel	60	300	Minimum preheat and interpass temperature for all thicknesses
S-3	Carbon molybdenum	175	-	Where either the specified minimum tensile strength is greater than 70,000 lb/in ² or thickness is greater than 5/8 inch
		60	-	For all other S-3 materials
S-3A	Manganese molybdenum and NiMo	300	500	For all thicknesses
S-4	Chromium molybdenum steel Cr 3/4-2 percent	250	-	Where either the specified minimum tensile strength is greater than 60,000 lb/in ² or thickness is greater than 1/2 inch
		60	-	For all other S-4 materials
S-5	Chromium molybdenum steel Cr > 2 percent	400	-	Where either the specified tensile strength is greater than 60,000 lb/in ² or has both specified chromium content greater than 6.0 percent and thickness greater than 1/2 inch
		300	-	For all other S-5 materials

See footnotes at end of table.

TABLE IV. Preheat and interpass temperature for welded ferrous alloys.
 - Continued

Material group number	Material identification	Minimum preheat temperature °F 1/. 2/. 3/	Maximum interpass temperature °F	Supplementary provisions for preheat and interpass temperature
S-6 5/	High alloy steel martensitic	400	-	For all S-6 materials except as permitted below
		300	500	For 410 welded with 410NiMo
		200	500	For 410S welded with 410NiMo unless otherwise permitted below
		60 4/	500	For 410S welded by SMAW with 410NiMo, with 0.03% C maximum, or when using GMAW or GTAW for 410S with 410NiMo filler material
S-6A	High alloy steel martensitic	200	500	For all S-6A material except as permitted below
		60 4/	500	For thickness less than 1.5 inches; and SMAW with 410NiMo electrode with 0.03% C maximum or when using GTAW or GMAW and 410NiMo filler material.
S-7	High alloy steel ferritic			Preheat is not mandatory - The preheat and interpass temperature used in qualifying the welding procedure shall be an essential element of that procedure, to be applied in production welding.
S-8	High alloy austenitic steel		350	Preheat and interpass temperature shall not exceed 350°F for all S-8 materials except as provided for in footnote 2.

See footnotes at end of table.

TABLE IV. Preheat and interpass temperature for welded ferrous alloys.
 - Continued

Material group number	Material identification	Minimum preheat temperature °F <u>1/</u> . <u>2/</u> . <u>3/</u>	Maximum interpass temperature °F	Supplementary provisions for preheat and interpass temperature
S-10H	High alloy steel duplex stainless	60	400	For all thicknesses.
S-11	-	-	-	See 6.5

- 1/ Where consumable inserts are used, preheat temperatures for GTA root welding (tacking and consuming the insert) can be the temperatures established in approved welding procedure qualification tests.
- 2/ Preheat and interpass temperatures for dissimilar metal welds, where specified temperatures for the different materials are not within the same range, shall be established by approved welding procedure qualification tests except as provided for in footnote 3.
- 3/ Where different combinations of S-1, S-3, S-3A, S-4, S-5, S-6, S-6A, and S-7 are welded, the preheat temperatures shall be the higher required for the materials involved except as provided for in footnote 1.
- 4/ These lower preheat temperatures are only permissible for SMAW when electrodes are specially procured to 0.03% maximum carbon content. Applicable welding procedures shall specify this requirement. Records required by 4.1.3 shall list the heat and lot number of all electrodes used with these lower preheat temperatures. A procedure for purchasing electrodes to this requirement and for segregating all such electrodes from high carbon content electrodes shall be developed by the activity and submitted for approval in accordance with 5.2.1 prior to use.
- 5/ The maximum interpass temperature for welding with all 410NiMo type filler materials shall be 500°F.

TABLE V. Preheat and interpass temperature for welded nonferrous alloys.

Material group number	Material identification	Minimum preheat temperature °F	Maximum interpass temperature °F	Supplementary provisions for preheat and interpass temperature <u>1/</u>
S-21 S-22 S-26	Aluminum and aluminum base alloys	60	-	Preheating may be used to control distortion and prevent cracking providing the preheat and interpass temperatures are supported by qualification tests. To prevent a reduction in resistance to stress corrosion cracking in alloys 5086 and 5456 temperatures between 150°F and 400°F should be avoided.
S-33	Silicon-bronze	60	-	Preheating may be used to control distortion and prevent cracking providing the preheat and interpass temperatures are supported by qualification tests.
S-34	Copper-nickel	-	350	Preheating is not required
S-35	Aluminum-bronze	300	-	
S-36A	Nickel-aluminum-bronze	-	-	Preheat is not mandatory. The preheat and interpass temperatures used in qualifying the welding procedure shall be essential elements of that procedure to be applied in production welding.

See footnotes at end of table.

TABLE V. Preheat and interpass temperature for welded nonferrous alloys.
- Continued

Material group number	Material identification	Minimum preheat temperature °F	Maximum interpass temperature °F	Supplementary provisions for preheat and interpass temperature 1/
S-36B	Manganese-nickel-aluminum-bronze	-	-	Preheat is not mandatory. The preheat and interpass temperatures used in qualifying the welding procedure shall be essential elements of that procedure to be applied in production welding.
S-37A	Manganese-bronze	300	-	Depending on welding process used, preheat and interpass temperatures from 500°F to 800°F may be necessary to ensure crack-free weldments.
S-37B	Nickel-manganese-bronze	-	-	Preheat is not mandatory. The preheat and interpass temperatures used in qualifying the welding procedure shall be essential elements of that procedure to be applied in production welding.
S-38	Tin-nickel-bronze	-	-	Preheat is not mandatory. The preheat and interpass temperatures used in qualifying the welding procedure shall be essential elements of that procedure to be applied in production welding.
S-39	Phosphor-bronze	-	-	Preheat is not mandatory. The preheat and interpass temperature used in qualifying the welding procedures shall be essential elements of that procedure to be applied in production welding.
S-42	Nickel-copper	-	350	Preheating is not required.

See footnotes at end of table.

TABLE V. Preheat and interpass temperature for welded nonferrous alloys.
- Continued

Material group number	Material identification	Minimum preheat temperature °F	Maximum interpass temperature °F	Supplementary provisions for preheat and interpass temperature ^{1/}
S-43	Nickel-chromium-iron and nickel-chromium-molybdenum-columbium		350	Preheating is not required.
S-44	Nickel-molybdenum-chromium alloy		200	Preheating is not required.
S-51 S-52 S-53	Titanium and titanium alloys	60	250	Interpass temperatures greater than 250°F shall require requalification of the procedure with the maximum interpass temperatures to be used for production.

^{1/} Preheat and interpass temperatures for dissimilar metal joints shall be those established by welding procedure qualification tests and approval.

6.3.1 Methods of preheating and interpass temperature control. Preheat may be applied by any method which ensures uniform temperature of the joint to be welded. Cyclic heating and severe temperature gradients in the welding area shall be avoided. Interpass temperature shall be controlled by:

- (a) Proper placement of preheat elements and control of power input.
- (b) Proper welding sequences.
- (c) Proper distribution of welders.

Welding operations shall be shielded from wind and inclement weather until the weldment has cooled to within ambient temperature plus 50°F, unless post weld stress relieving is required and is to be performed immediately upon completion of welding. Where gas torch flame is used for low temperature preheating, there shall be no condensation in way of welding.

6.3.1.1 Titanium and titanium alloys. Heating of S-51, S-52, and S-53 materials shall be limited to the use of lamps, resistance heaters or induction heating equipment. Use of oxy-fuel gas torches is prohibited. When using resistance heaters or induction coils, contact of the heating elements with the work shall be avoided.

6.3.2 Verifying temperatures. Preheat and interpass temperature shall be verified by periodic checks using such indicating devices as crayons or electrical potentiometers. Use of low melting metallic alloys for temperature measurement is prohibited. Crayon marks shall be located a minimum of 1 inch away from the weld area. Temperature indicating crayons shall not be used on S-51, S-52, and S-53 materials. For these materials the temperature shall be measured with a contact pyrometer.

6.4 Postheating. Unless otherwise approved, postheat of welded joints to relieve stresses and to improve the metallurgical and corrosion resisting properties of the heat affected zone shall be performed in accordance with table VI (ferrous alloy materials), section 8, and 6.4.1 through 6.4.6 (non-ferrous alloys). For dissimilar thicknesses, post weld heat treatment shall be based on the thicker member. Holding time at temperature shall be based on weld metal thickness, including reinforcement.

TABLE VI. Post heat requirements for welded ferrous alloys.

Material group number	Material identification 1/	Holding temperature °F 2/, 3/	Applicable supplementary provisions and exceptions		
			Machinery class M 1/	Pressure vessels, turbines classes A-F, A-LT, A-1, A-2, A-3, A-4, T-1, and T-2	Piping class P
6/ 4/ S-1	Carbon steel	1100-1250	Thermal stress relief shall be performed where required for dimensional stability.	<p>For class A valves installed in class P piping systems (see 3.3.2), stress relief may be performed according to class P requirements of this table.</p> <p>Thermal stress relief is required for all carbon steel pressure vessel classes except it is not mandatory for classes A-3 and A-4 of weld thickness 3/4 inch and less provided (a) that carbon is less than 0.35 percent, (b) there are no nozzles with finished inside diameter greater than 2 inches or connections forming ligaments that require increase shell or head thickness, (c) that if cellulose coated electrodes are used the joints shall be preheated to 200°F minimum and this preheat maintained during welding.</p>	<p>Thermal stress relief required when one or more of the following conditions apply:</p> <p>(a) Carbon content is over 0.35 percent.</p> <p>(b) Weld thickness is in excess of 3/4 inch.</p> <p>(c) Joints 2-1/2 inches nominal pipe size (nps) and larger are welded with cellulose coated electrodes and the preheat or interpass temperature was below 200°F.</p>

S9074-AR-GTB-010/278

Original 62

See footnotes at end of table.

TABLE VI. Post heat requirements for welded ferrous alloys. - Continued

Material group number	Material identification 1/	Holding temperature °F 2/. 3/	Applicable supplementary provisions and exceptions		
			Machinery class M 1/	Pressure vessels, turbines classes A-F, A-LT, A-1, A-2, A-3, A-4, T-1, and T-2	Piping class P
S-2	Quenched and tempered carbon steel	1000-1050	Thermal stress relief shall be performed where required for dimensional stability.	Thermal stress relief is required for all classes without exception.	Not applicable.
6/ 4/ S-3	Carbon Molybdenum alloy steels chromium <3/4 percent	1100-1250	Thermal stress relief mandatory should S-3 be used to fabricate class M machinery parts.	Thermal stress relief is mandatory for Mn-Mo steel welded fabrication in all classes; it is not mandatory for class A-3 when carbon-molybdenum steel is welded in thicknesses up to and including 5/8 inch. Thermal stress relief is required for all thicknesses over 5/8 inch except that it is not mandatory for nonpressure type attachment welds to pressure parts when the latter's carbon does not exceed 0.25 percent, and fillet welds that have throats 1/2 inch and less in thickness are used.	Thermal stress relief required for welded carbon-molybdenum piping only when one or more of the following apply: (a) carbon is over 0.25 percent (b) wall thickness is in excess of 5/8 inch (c) pipe size exceeds 4 inches maximum nominal outside diameter.
6/ S-3A	Mn-moly	1100-1175			

Original 63

S9074-AR-GIB-010/278

See footnotes at end of table.

TABLE VI. Post heat requirements for welded ferrous alloys. - Continued

Material group number	Material identification 1/	Holding temperature °F 2/, 3/	Applicable supplementary provisions and exceptions		
			Machinery class M 1/	Pressure vessels, turbines classes A-F, A-LT, A-1, A-2, A-3, A-4, T-1, and T-2	Piping class P
6/ Z/ S-4	Alloy steel (Cr content 3/4 - 2 percent, total alloy content 2 - 3/4 percent maximum)	1250-1375	Thermal stress relief mandatory should S-4 materials be used to fabricate class M machinery parts.	Thermal stress relief required. No exceptions. All attachments or parts welded thereto shall be stress relieved.	Except as specified in footnotes 5 and 7, thermal stress relief is required when any one of the following apply: (a) carbon content is over 0.15 percent, (b) wall thickness is in excess of 5/8 inch, (c) pipe size exceeds 4 inches maximum nominal outside diameter, (d) preheat and interpass temperature was below 250°F.
6/ Z/ S-5	Alloy steel (total alloy content 10 percent maximum)	1350-1400	Thermal stress relief mandatory should S-5 materials be used to fabricate class M machinery parts.	Thermal stress relief required. No exceptions. All attachments or parts welded thereto shall be stress relieved.	Except as specified in footnotes 5 and 7, thermal stress relief is required when any one of the following apply: (a) carbon content is over 0.15 percent, (b) chromium content is over 2.75 percent, (c) wall thickness is in excess of 5/8 inch, (d) pipe size exceeds 4 inches maximum nominal outside diameter, (e) preheat or interpass temperature was below 300°F.

S9074-AR-GIB-010/278

Original 64

See footnotes at end of table.

TABLE VI. Post heat requirements for welded ferrous alloys. - Continued

Material group number	Material identification 1/	Holding temperature °F 2/, 3/	Applicable supplementary provisions and exceptions		
			Machinery class M 1/	Pressure vessels, turbines classes A-F, A-LT, A-1, A-2, A-3, A-4, T-1, and T-2	Piping class P
S-6	High alloy steel martensitic	1250-1400 9/ 1100-1150 10/ 1st: 1225-1275 2nd: 1100-1150	Thermal stress relief mandatory should S-6 materials be used to fabricate class M machinery parts.	Thermal stress relief required. No exceptions. All attachments or parts welded thereto shall be stress relieved.	Thermal stress relief required for welds in all sizes of piping.
S-6A	High alloy steel martensitic	8/ 1100-1150	Thermal stress relief mandatory should S-6A materials be used to fabricate class M machinery parts	Thermal stress relief required. No exceptions. All attachments or parts welded thereto shall be stress relieved.	Thermal stress relief required for welds in all sizes of piping.
S-7	High alloy steel ferritic	1350-1425	Thermal stress relief mandatory should S-7 materials be used to fabricate class M machinery parts.	Thermal stress relief required. No exceptions. All attachments or parts welded thereto shall be stress relieved.	Thermal stress relief required for welds in all sizes of piping.

See footnotes at end of table.

Original 65

S9074-AR-GIB-010/278

TABLE VI. Post heat requirements for welded ferrous alloys. - Continued

Material group number	Material identification 1/	Holding temperature °F 2/, 3/	Applicable supplementary provisions and exceptions	
			Machinery class M 1/	Pressure vessels, turbines classes A-F, A-LT, A-1, A-2, A-3, A-4, T-1, and T-2
				Piping class P
S-8	High alloy austenitic steel		<p>Weldments of austenitic corrosion resistant steel shall not be post-weld heat treated unless otherwise specified herein or in the controlling component specification. Annealing or solution treating of austenitic corrosion resistant steel shall be done only for putting precipitated carbides back into solution and only for those weldments that can be entirely water quenched immediately after heating. When such heat treatment is required, the weldment shall be heated to a temperature of between 1950 and 2050°F, held at that temperature for 1 hour for each inch or fraction thereof of thickness at the thickest part, and then the entire weldment shall be water quenched. Post weld heat treatment of CN-7M or CN-7MS stainless steel castings is required to restore the corrosion resisting properties of the material. Heat treatment shall consist of heating the casting to 2050°F minimum, hold for sufficient time to heat the casting to temperature, and then quench in oil or water. However, post weld heat treatment is not required for welding on the nonwetted surface (casting surface which is not exposed to sea water) where such welding can be accomplished without causing any portion of the wetted surface to be heated to a temperature exceeding 800°F.</p>	
S-10H	High alloy duplex stainless steel		<p>Weldments of duplex stainless steel shall not be post-weld heat treated unless otherwise specified herein or in the controlling component specification. Annealing or solution heat treating shall be done only for putting precipitated carbides or sigma phase back into solution and only for those weldments that can be entirely water quenched immediately after heating. When such heat treatment is required, the weldment shall be heated to a temperature of between 1900 and 1975°F, held at that temperature for 1 hour for each inch or fraction thereof of thickness at the thickest part, and then the entire weldment shall be water quenched. When this option is exercised, test samples shall be removed from the heat treated parts, or test coupons from the same heat and lot as the heat treated subassemblies and heat treated with the parts, shall be tested as required by the base material specifications. The heat treatment procedure, including the mechanical test specimen requirements, shall be submitted for approval.</p>	

S9074-AR-GIB-010/278

Original 66

See footnotes at end of table.

TABLE VI. Post heat requirements for welded ferrous alloys. - Continued

Material group number	Material identification 1/	Holding temperature °F 2/, 3/	Applicable supplementary provisions and exceptions		
			Machinery class M 1/	Pressure vessels, turbines classes A-F, A-LT, A-1; A-2, A-3, A-4, T-1, and T-2	Piping class P
S-11	Low alloy quenched & tempered steel		Stress relief of S-11 materials is prohibited unless specifically approved by NAVSEA. See 6.5.		

Footnotes to table VI:

- 1/ Materials used in the fabrication of machinery components and not covered in this table shall be stress relieved in accordance with the conditions established by approved welding procedure qualification tests.
- 2/ For quenched and tempered or normalized and tempered alloys, stress relief temperatures shall not exceed base metal tempering temperatures and, in general, should be approximately 50°F below tempering temperature.
- 3/ Minimum holding time at temperature shall be 1 hour per inch of thickness. For thicknesses less than 1 inch, the holding time shall be proportional to the thickness but not less than 30 minutes.
- 4/ When it is impractical to post-weld heat treat at temperatures specified in table VI, it is permissible to use lower temperatures for longer periods of time as follows:

Temperature decrease below specified temperature °F	Minimum holding time at decreased temperature, hours per inch of thickness
50	2
100	3
150	5
200	10

- 5/ Where carbon content of pipe or fitting exceeds 0.15 percent but is not greater than 0.20 percent, stress relief is not required for socket welds 2 inches nps and under, provided welding is done with the low carbon type electrodes (80XX-B2L for 1-1/4 Cr-1/2 Mo; and 90XX-B3L for 2-1/4 Cr-1 Mo).

Original 67

S9074-AR-GIB-010/278

TABLE VI. Post heat requirements for welded ferrous alloys. - Continued

- 6/ The post weld thermal stress relief requirement of the ASME Code, sections I and VIII, as applicable, may be used provided the holding temperature ranges specified in this table are used. The table selected shall be used in its entirety, exclusive of the others.
- 7/ Stress relief is not required for the following welds in 2-1/4 Cr-1 Mo and 1-1/4 Cr-1/2 Mo boiler superheaters when welded in accordance with NAVSEA 0951-LP-031-8010 or NAVSEA 0951-LP-038-6030, as applicable, using low carbon (0.05 maximum carbon content) filler material.
- (a) External superheater tube-to-header welds of NAVSEA 0951-LP-038-6030 figure 7-2 and repairs to these welds which are not deeper than maximum design weld joint depth.
 - (b) Internal superheater tube-to-header "seal" welds which have a maximum groove depth, before welding, of 1/4 inch or less, where tubes are fully rolled into the header prior to welding. For the purpose of this requirement, groove depth shall be determined at the location of minimum counterbore depth.
 - (c) Weld repairs to internal superheater tube-to-header "seal" welds which extend no deeper below the header inside surface than "b" above.
 - (d) Tube plug seal welds of 1/4-inch maximum throat thickness.
 - (e) Handhole plate seal welds of 5/16-inch maximum throat thickness where handhole plates are entirely secured by an integral threaded system.

Omission of stress relief for any other welds (that is, internal tube-to-header "seal" welds of greater than 1/4-inch groove depth, tube hole repairs, minor header repairs, and so forth) shall require specific approval by NAVSEA.

- 8/ Part must be cooled to ambient temperature before final heat treatment. Minimum hold time at temperature shall be 2 hours. Above 2 inch thickness add 1 hour for each additional inch, or fraction, of thickness. A double temper heat treat cycle with $1250 \pm 25^\circ\text{F}$ for the first temper is permissible. The final temper shall be $1125 \pm 25^\circ\text{F}$. Minimum hold time for each temper shall be 2 hours plus 1 hour for each inch, or fraction, of thickness over 2 inches.
- 9/ This holding temperature shall be used for 410 or 410S steel welded with 410NiMo weld metal. Part must be cooled to ambient temperature before final heat treatment. Minimum hold time at temperature is 4 hours. Above 4 inches add 1 hour for each additional inch, or fraction, of thickness. Separate welding procedure qualification using these temperatures is required; HAZ toughness testing shall be performed.
- 10/ An alternate double temper heat treat cycle for 410 or 410S steel welded with 410NiMo weld metal. Part must be cooled to ambient temperature before 1st and 2nd parts of heat treat cycle. Minimum time at temperature for each part of heat treat cycle is 2 hours. Above 2 inches add 1 hour for each additional inch, or fraction, of thickness. Separate welding procedure qualification using these temperatures is required.

6.4.1 Nickel alloys. Postweld heat treatment of the following nonferrous alloys shall not be performed unless it is necessary for dimensional stability, in which case temperatures shall be as indicated:

<u>Materials</u>	<u>Holding temperatures, °F</u>	<u>Holding time</u>
Nickel-copper alloy (S-42)	See Note	1 hour per inch of thickness. For thicknesses less than 1 inch, the holding time shall be proportional but not less than 30 minutes.
Copper-nickel alloy (S-34)	575 ± 25	
Nickel-chromium-iron (S-43)	See Note	

NOTE: Weldments to be post-weld heat treated shall not contain weld deposits made with electrode type 3Ni10 or 8Ni10 of MIL-E-22200/3 or electrode types E NiCrMo-4/ER NiCrMo-4 of AWS A5.11 and A5.14 respectively. Precipitation hardened nickel-copper weldments shall not be stress relief heat treated. Copper-nickel alloy welded with copper-nickel or nickel-copper filler materials may be stress relief heat treated for dimensional stability (subject to the prohibitions against types 3Ni10 and 8Ni10 electrodes). Holding temperatures for S-42 and S-43 materials shall require NAVSEA approval prior to the performance of any post weld heat treatment. The responsible activity shall recommend the desired holding temperature and shall provide sufficient technical information to demonstrate that required mechanical properties will be maintained.

6.4.2 Aluminum alloys. Post-weld heat treatment shall not be performed on wrought aluminum alloys.

6.4.3 Alloys not specifically covered. Post-weld heat treatment of alloys not covered by this document shall be considered for approval on the basis of the qualification tests where such post-weld heat treatment is an essential element of the welding procedure.

6.4.4 Age hardenable alloys. Where the specified aging heat treatment cannot be performed or where filler metals are used that do not respond to aging heat treatment, a design review shall be performed to ensure that the weldment satisfies design requirements and NAVSEA approval for repair shall be obtained.

6.4.5 Copper alloys. In general, copper alloy castings do not require post-weld heat treatment to improve corrosion resistance. An exception to this is nickel-aluminum bronze in accordance with MIL-B-24480, where a post-weld temper anneal heat treatment is required if the weld is made on any surface exposed to seawater or where the heat affected zone extends to within 1/4 inch of this surface. Post-weld heat treatment is not required for non-seawater applications. When required, temper annealing shall consist of holding the casting at 1250 ± 25°F for 6 hours minimum, followed by air cooling.

6.4.6 Titanium and titanium alloys.

6.4.6.1 General heat treating requirements. For furnace equipment requirements, heat treating procedures, minimum metal removal after exposure to high temperatures, and general information, refer to MIL-H-81200.

6.4.6.2 Stress relieving. When required for dimensional stability, S-51 and S-52 materials shall be stress relieved in the temperature range of 900° to 1100°F for 1-1/4 hour per inch within the range of 1/4 to 4 hours. S-53 materials shall be stress relieved in the temperature range of 900° to 1200°F for 1 hour per inch, within the range of 1 to 4 hours.

6.4.6.3 Annealing. When required to improve ductility, dimensional or thermal stability, fracture toughness, and creep resistance, S-51 and S-52 materials shall be annealed in the temperature range of 1200° to 1400°F for 1-1/4 hours per inch, within the range of 1/3 to 2 hours. S-53 material shall be annealed in the temperature range of 1275° to 1500°F for 1 hour per inch, within the range of 1/3 to 2 hours.

6.5 Special requirements for welding and forming S-11 steels and special treatment steels (STS). Welding and forming of HY/HSLA steels and STS steels shall be in accordance with MIL-STD-1681, MIL-STD-1688 or MIL-STD-1689, as applicable. Preheat and interpass temperatures, filler metal selection, and postheat temperature and holding time for MIL-S-23284 steel shall conform to the requirements of MIL-STD-2191; welding procedure qualification shall employ MIL-S-23284 steel unless otherwise approved by NAVSEA.

6.5.1 Special requirements for welding with MIL-120 and MIL-140 series filler materials. Except for MIL-STD-2191 applications and handling and storage of MIL-12018 electrodes (see 6.6), additional requirements shall be as approved by NAVSEA for welding with MIL-120 and MIL-140 series filler materials. These additional requirements involve at least the following items:

- (a) Heat input (minimum and maximum) requirements.
- (b) Heat soaking requirements of welds and weld repairs (as required).
- (c) Preheat and interpass temperature (minimum and maximum) requirements.
- (d) Loss of preheat or heat soak and weld removal requirements.
- (e) Ordering requirements.
- (f) Receipt inspection of welding filler materials.
- (g) Weld repairs of base material.
- (h) Weld repairs using undermatching filler materials in lieu of MIL-120 or MIL-140 series filler materials.

6.6 Electrode handling and storage.

6.6.1 General. Welding electrodes, including covered types and bare spooled electrode (wire form) shall be handled so as to prevent damage. Where containers show evidence of damage, their contents shall be examined and electrodes with cracked or flaked-off coatings, or damaged spools of filler metal shall not be used for production welding. Covered electrodes and bare electrodes (wire form) and rods

shall be stored under clean dry conditions to prevent damage from contamination, moisture, or water.

6.6.1.1 Covered electrodes (excluding MIL-types 9018, 10018, 11018, 12018, 10018-N1, and 410NiMo). Low hydrogen types, including ferritic, austenitic and nonferrous alloy types, except MIL-types 9018, 10018, 11018, 12018, 10018-N1, and 410NiMo or similar AWS or ASTM types (see 6.6.2) shall be used within 9 hours after removal from hermetically sealed containers or holding oven. The holding oven shall be a vented type and a temperature of 150 to 350°F shall be maintained. Electrodes exposed to ambient conditions for more than 9 hours after removal shall be held for at least 8 hours at 150 to 350°F in a vented oven prior to reissue.

6.6.2 Conditioning electrodes (MIL-types 9018, 10018, 11018, 12018, 10018-N1, and 410NiMo and type E2209-15/16). Electrode MIL-types 9018, 10018, 11018, 12018, 10018-N1, and 410NiMo and type E2209-15/16 shall be conditioned in accordance with 6.6.2.1 through 6.6.2.4.

6.6.2.1 Exposed electrodes. Electrodes removed from holding ovens or hermetically sealed containers shall not be used if they are exposed to the atmosphere for more than 5 hours. Electrodes which have been exposed for more than 5 hours shall be stored in the holding oven for at least 8 hours or baked in accordance with 6.6.2.3. Electrodes which meet the moisture and moisture resistance requirements as specified in MIL-E-22200/10 may be used for a period of 9 hours without baking.

6.6.2.2 Storage in holding ovens. Electrodes should be stored in holding ovens upon opening the hermetically sealed containers. Electrodes which have been baked shall be transferred to holding ovens before cooling to 150°F. The temperature of the holding oven shall be 225 to 300°F.

6.6.2.3 Baking. Electrodes shall be conditioned by baking at temperatures of $800 \pm 50^\circ\text{F}$ ($625 \pm 25^\circ\text{F}$ for MIL-410NiMo-XX) for 1/2 to 1 hour in a forced convection or circulation oven. The oven temperature at time of loading shall not exceed 300°F and the electrodes should be spread in thin layers on trays. During baking, the temperature shall not be raised more than 300°F for each hour when oven temperatures are 500°F and above. Ovens should be automatically controlled and calibration shall be checked periodically at intervals of not more than 6 months.

6.6.2.3.1 Rebaking. Rebaking of electrodes is permitted, provided tests are performed on each electrode brand to confirm that the number of rebaking cycles to be used does not adversely affect weld deposit quality in accordance with governing specification requirements.

6.6.2.4 Moisture test. Moisture test of electrode coatings at the jobsite is not required.

6.6.3 Submerged arc granular flux for general welding.

6.6.3.1 Storage. Granular flux shall be stored in a dry area.

6.6.3.2 Reuse. Except as specified in 6.6.4, unfused granular flux may be reused subject to the following conditions:

- (a) Flux shall be collected from clean, dry work pieces.
- (b) Flux should be mixed with new flux.

6.6.4 Submerged-arc granular flux for welding high hardenable alloys.

6.6.4.1 Preparation for use. Prior to the start of any welding operation, granular flux shall be heated to 250°F minimum and used while warm to the touch. Flux shall be heated in clean, uncoated metal containers. Requirements for flux for S-11A and S-11C materials shall be in accordance with MIL-STD-1689 or MIL-STD-1688 as applicable.

6.6.4.2 Reuse. Unfused granular flux may be reused subject to the following conditions:

- (a) Flux shall be collected from clean, dry work pieces.
- (b) Flux should be mixed with approximately 50 percent new flux.
- (c) If flux is not warm to the touch, it shall be reheated to 250°F minimum.

6.6.5 Titanium and titanium alloy electrodes. Bare spooled electrodes and bare rod electrodes shall be kept in their original sealed containers until used. To prevent contamination, wire and rod shall be handled only with clean fabric gloves except leather may be used in actual welding. Once mounted on the wire spool hub, the titanium wire shall be kept enclosed in a dust cover. The wire feed path shall be cleaned at least once daily to remove any accumulated chips or dirt in the guide tube, rollers, or torch. Manually fed wire or rod shall be wiped with a clean solvent-soaked cloth before use and thereafter handled only with clean gloves. Wire or rod shall always have 1-inch of filler length removed from the tip before reuse. Wire and rod not in use for an extended period shall after removing the contaminated stub end be placed in clean, dust-free containers. Prior to reuse, this wire or rod electrode shall be wipe-tested by drawing a clean, lint free cloth, wet with solvent, along a 12-inch length of the electrode. A slight darkening or smudge on the cloth is acceptable but any evidence of foreign material coming off the electrode is cause for rejection until the wire is double-wiped with solvent, respooled, and passes the wipe test.

6.7 Production testing of S-51, S-52 and S-53 welds. See 40. in appendix A.

7. WORKMANSHIP REQUIREMENTS

7.1 General. This section contains the minimum requirements for workmanship practices and methods to ensure sound welded joints.

7.2 Cleaning prior to and during welding. The joint members to be welded, including the base metal surfaces, shall be cleaned to remove foreign material for a minimum of 1 inch from the weld edge. Mill scale or metallic oxides shall be removed from surfaces on which weld metal will be deposited. Slag shall be removed from all weld metal surfaces prior to depositing subsequent passes or layers and upon completion of the weld. For S-10H materials, wire brushing shall be accomplished using stainless steel brushes which have not been used on alloys other than stainless steels.

7.2.1 Seal welding in areas having threaded connections. Threads in the seal weld and inspection areas of threaded connections shall be removed prior to welding and subsequent inspection.

7.2.2 Titanium preweld preparation. As a minimum, all contaminants shall be removed from the weld joint surface (i.e., surfaces to be welded over) and the adjacent 1-inch of material prior to welding. Weld joint surfaces shall also be free of discoloration. Preparation of surfaces shall not deposit iron or other deleterious contaminants that are not subsequently removed from base metal surfaces. Unless otherwise approved by NAVSEA, the following shall be performed, as a minimum, prior to welding. Forged and cast surfaces and surfaces heat treated in air which will be welded over shall require a minimum of 1/32 inch metal removal. Weld joint should be prepared by machining with carbide or ceramic tools. If high speed steel tooling is used, weld joint surfaces shall be dressed with carbide burrs to remove any embedded steel particles. Weld joint surfaces prepared by shearing, sawing, etc. shall also be dressed with a carbide burr to remove all surface markings from the cutting operation (see 11.3.1 for cleaning of thermal cut surfaces). The final surfaces shall be brushed with a stainless steel wire brush, and then wiped along with 1-inch of adjacent material with solvent.

7.2.3 Titanium interpass cleaning. Where required, discoloration shall be removed by burring or filing type operations. Except for S-53 materials, straw color may be removed by stainless steel wire brushing. Should discoloration of a weld bead occur, the cause shall be determined and corrected prior to further welding. Where cleaning and defect removal type operations on weld beads in titanium materials are performed, requirements of 7.2.2 shall be met.

7.3 Peening of welds. Welds may be peened to help control distortion, to relieve stresses, or to improve weld quality. When peening is performed on weld layers subject to nondestructive evaluation, all visual evidence of peening or smeared metal shall be removed. Peening of the first or last layer of pipe welds shall not be performed. Peening shall be performed using a round or blunt nosed tool of circular or oblong cross section. Welds shall not be overpeened, causing flaking and laps or reducing the cross section of the adjacent base metal. Surface slag, slag inclusions, cracks, porosity, and other weld defects shall be removed prior to peening. Welds in S-51 and S-52 materials shall only be peened using

NAVSEA approved procedures and equipment. Peening of welds in S-53 materials shall not be permitted.

7.4 Butt welds. Butt welds shall be as follows:

- (a) Welds shall have complete penetration, when required, for the full length. Undercutting, overlapping, and sharp-ridged or deep-valleyed surface conditions shall be avoided. The reinforcement need not be removed except as required to meet reinforcement requirements. Where nonremovable backing strips are used, such strips are not considered to be weld reinforcements.
- (b) Before applying weld metal on the reverse side of double welded joints, the joint shall be prepared for welding by chipping, grinding, machining, or arc-air gouging to remove all unsound weld metal, except as permitted in section 9. Proper contouring and clearing shall be achieved as preparation for sound reverse root welding (see 9.3.2.1.1).

7.5 Thermal cut surfaces. Thermal cut surfaces for welding shall meet the acceptance standards of 11.3 and sample 2 or better of AWS C4.1-6. For S-10H materials, thermal cut edges shall be ground or machined to bright metal prior to welding.

7.6 Alignment of joint members. Joints shall be fitted and aligned in position. Tack welds or mechanical devices may be used to retain the alignment during welding. Tack welds shall be removed by suitable methods so that they do not become part of the welded joint unless they are made using approved welding procedures and meet the requirements of 10.3.8.

7.7 Repairs. Weld defects, defined herein as unacceptable, and detected by visual test (VT) or other NDT methods, shall be removed and repaired only to the extent necessary to render the area acceptable. All visual evidence of arc-strikes, weld or HT prod, shall be removed by grinding and repaired if necessary to meet minimum thickness requirements. Arc-strikes which reduce metal thickness below the minimum design requirement shall be repair welded. Discoloration on metal surfaces due to HT inspection shall be disregarded. Excavations resulting from defect removal shall not require repair welding unless the depth and extent of the excavation exceeds the allowable depth and extent of acceptable weld undercut allowed by MIL-STD-2035 for the class of welding, or unless any portion of the excavation reduces the remaining metal thickness below the minimum design thickness for the part or weldment.

7.7.1 Excavations not requiring repair welding shall blend smoothly and gradually with the adjacent weld metal or base material. Excavations not requiring repair welding shall be HT or PT examined if HT/PT inspection is a requirement for the class of welding.

7.7.1.1 For all arc strikes that occurred after final heat treatment in S-1 materials with carbon content greater than 0.30 percent, S-3, S-3A, S-4, S-5, S-6, and S-6A materials, complete removal of the heat affected zone shall be verified

with an etchant that has been demonstrated to disclose heat affected zone structure in the material involved unless repair welding is required. Etchants shall be prepared and used in accordance with good metallurgical practice.

7.7.2 Excavations requiring repair welding shall be MT/PT examined or visually examined at 5X magnification, prior to repair welding, if MT/PT inspection is a requirement for the class of welding. Excavations requiring repair welding shall be welded only to the extent necessary to restore minimum design thickness or to achieve a condition equivalent to acceptable depth and extent of weld undercut. Repair welds of excavations, if required, shall be inspected by the same NDT method as the original weld. Except where the repair welded excavation of previously accepted radiographed or ultrasonically tested welds does not exceed 3/16 inch or 20 percent of the base metal thickness, whichever is less, the repair may be MT/PT inspected in lieu of radiographic testing (RT) or ultrasonic testing (UT). The total thickness, repair weld plus base metal, shall be used for determining the approved acceptance criteria. See 13.2.8.1 for additional requirements for S-51, S-52, and S-53 materials.

7.8 Marking. Marking of welds for identification purposes, such as may be required in mapping of joints, record keeping, and establishing responsibilities for workmanship and quality of welding, shall be done preferably with an electro-etch pencil or vibro-tool method. Where it may be necessary to retain identification markings and the electro-etch pencil or vibro-tool methods are inadequate due to application of paint or other coatings which may tend to obliterate such marking, the low-stress round-bottom impression stamping method may be used in lieu of vibro-tool or electro-etch methods. Where the stamping method is used, impression should be placed on the thicker joint member, such as fittings in piping systems or the lowest stressed surfaces of other classes of welding. Pipe and tubing shall not be stamped. The maximum allowable depth of the impression shall be 0.01 inch and the impression tool shall be in accordance with the following requirements.

Character size (inches)	Minimum character face radius (inches)
1/16	0.005
3/32	0.006
1/8	0.007
3/16	0.008
1/4	0.010

The depth of the impressions shall not reduce material thickness below the minimum thickness required by design. Marking shall be located so as not to interfere with interpretation of radiography.

7.9 Defect removal. Defects, whether from weld or base material, may be removed by grinding, machining, or filing with clean tools. The removal process shall not deposit iron, lead or other deleterious contaminants on the surface of corrosion resistant material. For titanium and titanium alloys, see 7.2.2. If weld

repair is not required to meet minimum thickness specifications, the excavation shall be blended smoothly into the adjacent material.

7.10 Titanium and titanium alloy welds.

7.10.1 Thermal gouging. Thermal methods shall not be employed for backgouging or defect removal.

7.10.2 In process color inspection. Each weld pass, including the backside of two sided welds, shall be inspected for color in the as-deposited condition before brushing and cleaning, and shall meet the criteria of table XI, note 5. Results shall be recorded where required by 4.1.3, note 2. This inspection may be performed by the production personnel if trained and periodically audited to ensure proficiency in accordance with a program approved by the activity's MIL-STD-271 test examiner.

8. POST WELD HEAT TREATMENT

8.1 General. Unless otherwise specified in the qualified welding or heat treatment procedure, post-weld thermal stress relief heat treatment shall be performed in accordance with table VI, 6.4, and this section.

8.2 Special requirements.

8.2.1 Dissimilar metal joints. When parts of two different S-number groups are joined by welding, the post-weld heat treatment temperatures shall be selected on the basis of preserving the mechanical properties of the more critical of the two materials for the application concerned.

8.2.2 Post-weld heat treatment for different thicknesses of plate in pressure vessels. When the welded joint connects parts of pressure vessels that are of different thicknesses, the thicknesses to be used in applying the requirements for post-weld heat treatment shall be as follows:

- (a) The thinner of two adjacent butt-welded plates including heat to shell connections.
- (b) The thicker of the shell or head plate in connections to intermediate heads.
- (c) The thickness of the shell in connections to tube sheets, flat heads, covers, or similar constructions.
- (d) The thickness of the shell or head plate in nozzle attachment welds.
- (e) The thickness of the nozzle neck at the joint in nozzle neck to flange connections.
- (f) The thickness of the pressure part, at the point of attachment, where a nonpressure part is welded to a pressure part.

8.3 Ferrous material. Post-weld heat treatment for ferrous materials shall be in accordance with table VI.

8.4 Nonferrous material. Post-weld heat treatment for nonferrous materials shall be in accordance with 6.4.1 through 6.4.6.

8.5 Post-weld heat treatment procedures (furnace).

8.5.1 Loading temperature. The furnace temperature shall not exceed 800°F at the time weldment is placed in it.

8.5.2 Rate of heating. The rate of heating above 800°F shall be not more than 400°F per hour divided by the maximum metal thickness of the component or vessel in inches, but in no case more than 400°F per hour (see 8.5.7).

8.5.3 Temperature variation during heating and cooling cycles. During the heating and cooling period, the portion of the weldment being heated shall not vary more than 250°F between the highest and lowest reading.

8.5.4 Holding temperature variation. Holding temperature shall be considered the mean between the highest and the lowest thermocouple readings. Thermocouple readings shall be within the temperature ranges specified for the materials involved: table VI for ferrous materials, nickel alloys (see 6.4.1), and other alloys as approved. During the holding time at the specified stress-relieving temperature, the maximum temperature difference between any two points on the weldment shall not exceed 100°F.

8.5.5 Preventing oxidation and distortion. During the heating and holding periods the furnace atmosphere shall be controlled to minimize surface oxidation. Flame shall not impinge directly on the weldment for which support shall be provided if required to minimize sagging due to its weight and the effect of high temperatures.

8.5.6 Rate of furnace cooling. Except for materials that are quenched from post-weld heat treatment temperatures, cooling above 800°F shall be done in a closed furnace or cooling chamber at a rate not greater than 200°F per hour. From 800°F, vessel or component may be cooled in still air provided it is protected from inclement conditions and drafts (see 8.5.7).

8.5.7 Special considerations (heating or cooling rates). The rates of heating and cooling need not be less than 100°F per hour. However, consideration of closed chambers and complex structures may indicate the need to reduce loading temperatures and rates of heating and cooling to avoid structural damage due to excessive thermal gradients.

8.5.8 Post-weld heat treatment of titanium and titanium alloys shall be performed in accordance with MIL-H-81200 and the additional requirements of 8.8.

8.6 Post-weld heat treatment procedures (local).

8.6.1 Heating method. Post-weld heating shall be accomplished by electric inductance or electrical resistance devices, or other approved local heating methods.

8.6.2 Heating rate, holding temperature variation, and cooling rate. The heating rate of localized heating shall not exceed 40°F per 5-minute period. Holding temperature variation and rate of cooling shall be in accordance with 8.5.4 and 8.5.6 respectively.

8.6.3 Postheating piping welds. The width of circumferential band to be heated shall be at least equal to 3 times the wall thickness, but in no case less than 1-1/2 times the width of the weld face, on each side of the joint. Where a pipe is welded to a valve, the width of the heated zone may be decreased on the valve side to a minimum distance, measured from the edge of the weld, equal to the width of the weld face.

8.6.4 Postheating pressure vessels. Circumferential welded joints may be heat treated by uniformly heating a circumferential band having a minimum width of 6 times the material thickness on each side of the joint. Nozzles or other welded attachments for which post-heat treatment is required may be treated by locally heating a circumferential band around the entire vessel with the connection at the center of the band. The band width shall be a minimum of 6 times the material thickness on each side of the attachment. Local postheat treatment for applications other than those listed above will not be permitted without approval by the contracting activity of the detailed procedure.

8.7 Postheating repaired welds in pressure vessels and piping. Unless otherwise approved, vessels or parts of vessels and piping that have been heat treated in accordance with section 8 shall again be postweld heat treated after repair or alterations have been made.

8.8 Heat treatment of titanium and titanium alloys. Protective (inert gas) atmospheres, vacuum, or molten salts can be used, when needed, to protect surfaces from oxidizing or reducing reactions, contamination, and changes in carbon content or embrittlement by undesirable elements such as hydrogen, oxygen, or nitrogen. Refer to MIL-H-81200.

8.8.1 Gases used for protective atmospheres shall be limited to argon or helium meeting the requirements of 30.2.1.

8.8.2 When parts are heat-treated in a vacuum furnace, the furnace shall be purged and backfilled twice before heating with pure argon or helium meeting the requirements of 30.2.1. The furnace may also be backfilled during cooling with the argon or helium.

8.8.3 When salt baths are used for heat treating, the salt mixtures shall consist mostly of nonchloride oxidizing salts with chloride limited to 2000 ppm maximum. Reducing or nitriding salts shall not be used.

8.9 Temperature measuring methods.

8.9.1 Pyrometric equipment. Pyrometric recording equipment shall be provided to indicate the temperature of the weldment and not the furnace except as specified in 8.9.4. The average of the observed temperatures of the weldment is considered to be the temperature of the weldment provided all observed temperatures are within the temperature range specified in table VI.

8.9.2 Locating thermocouples. Thermocouples shall measure the temperature at the anticipated hottest point on the weldment and at the anticipated coolest point. The number of thermocouples provided shall assure complete coverage of the weldment and adequate temperature history. If more than one weldment is to be stress relieved at the same time, thermocouples shall be attached to each weldment. In no case, however, shall more than six thermocouples be required for a furnace charge. For local heating operations, not less than two thermocouples shall be attached to the weldment. When only two thermocouples are used, they shall be separated by a distance equal to 3 times the width of the weld reinforcement with the weld centered

between them. For flange to pipe joints, one thermocouple shall be attached to the flange side of the joint.

8.9.3 Installing thermocouples. Thermocouple wires shall be electrically insulated except at their hot junctions. In order to avoid erroneous readings, thermocouples shall be so arranged that flames do not impinge on the junctions of the wires themselves. When the electrical resistance heating method is used, the thermocouple provided to control the operation shall be covered by a protective wrapping to prevent direct radiation of the heating elements on its hot junction. Thermocouples shall be attached to the weldment by a method which ensures that the thermal junction is held firmly.

8.9.4 Pyrometrically controlled furnaces. For furnace stress relief of weldments, when a recording pyrometric control furnace has been calibrated and it is verified that the temperature variation within the furnace is within the stress relieving temperature range for the materials involved, the furnace control thermocouples may be used as the indication of the temperature of the part being treated in lieu of thermocouples attached to the component.

9. DESIGN REQUIREMENTS FOR WELDED JOINTS

9.1 General. This section contains the minimum requirements for the design of welded joints for machinery, piping, pressure vessels, and turbines (M, P, A, and T). Piping schedules and fabrication details for specific piping systems of surface ships and submarines are covered in MIL-STD-777 and MIL-STD-438 respectively. Within this document design group classifications consist of butts, tees, corners, and partial penetration type joint designs.

9.2 Joint design. Unless otherwise approved or unless otherwise modified by the application and limitations of MIL-STD-777 or MIL-STD-438, the design of welded joints for classes M, P, A, and T shall be as shown in table VII. Figure 1 gives examples of acceptable nozzle and flange joint locations for radiography.

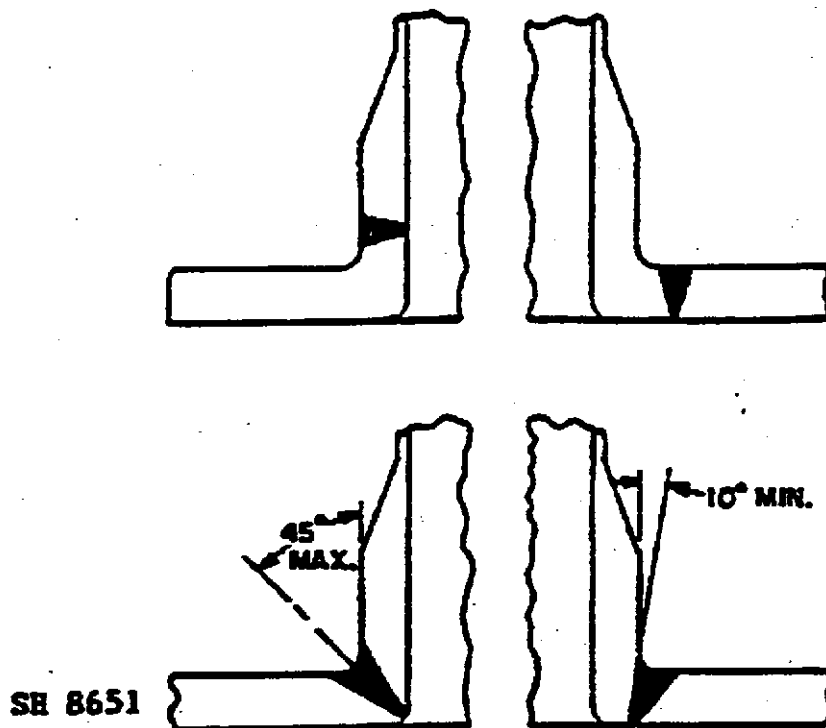

FIGURE 1. Examples of acceptable weld joint locations.

TABLE VII. Approved weld joint designs. 1/

Service classification	Approved joint efficiencies and notes 14/	Joint identification numbers (MIL-STD-22)
Machinery class M	100 percent efficiency	B1V.1 B2V.1 B2U.5 CIV.5 CIV.12 C2J.1 C2S.1 B1V.2 B2V.3 B2J.1 CIV.6 C2V.1 C2J.2 C2S.2 B1V.3 B2S.1 B2J.2 CIV.7 C2V.2 C2J.3 TIV.1 B1V.5 B2U.1 B2J.3 CIV.8 C2V.3 C2J.4 TIV.2 B1V.6 B2U.2 B2J.4 CIV.9 C2V.4 C2J.5 T2V.1 B1V.7 B2U.3 B2(S)V.2 CIV.10 C2V.5 C2J.6 T2V.2 B1S.2 B2U.4 B2(S)V.4 CIV.11 C2V.6 C2U.1 T2J.1 T2J.2
	80 percent efficiency	B1S.1 CIV.2 CIV.4 CIJ.1 CIJ.3 CIJ.5 C1S.2 T1J.1 CIV.1 CIV.3 CIU.1 CIJ.2 CIJ.4 C1S.1 TIV.3
	2/	E1V.1 E1U.1 PT2S.1 PT2S.3 PT2V.2 PT2J.2 LIV.2 LIS.2 E1S.1 E1U.2 PT2S.2 PT2V.1 PT2J.1 LIV.1 LIS.1 L2S.1
Pressure vessel classes A-1, A-2, A-3, A-4, A-F, A-LT	100 percent efficiency 3/ 4/ 5/ 6/ 13/	B1V.1 B1V.7 B2U.3 B2J.3 C2V.2 C2J.5 P-70 V-9 B1V.2 B2V.1 B2U.4 B2J.4 C2V.5 C2J.6 P-71 V-11 B1V.3 B2V.3 B2U.5 B2(S)V.2 C2V.6 P-14 P-72 V-12 B1V.5 B2U.1 B2J.1 B2(S)V.4 C2U.1 P-63 V-7 V-27 B1V.6 B2U.2 B2J.2 C2V.1 C2J.4 P-64 V-8 V-28
Pressure vessel classes A-3, A-4	100 percent efficiency 3/ 5/ 6/	V-4 V-25 V-5 V-26 V-6 V-21 V-22
Pressure vessel class A-4	100 percent efficiency 3/ 5/ 6/	B2S.1 CIV.8 C2V.1 C2V.6 C2J.5 TIV.1 T2J.2 B2(S)V.2 CIV.9 C2V.2 C2J.1 C2J.6 TIV.2 PT2S.1 CIV.5 CIV.10 C2V.3 C2J.2 C2S.1 T2V.1 V-23 CIV.6 CIV.11 C2V.4 C2J.3 C2S.2 T2V.2 V-24 CIV.7 CIV.12 C2V.5 C2J.4 C2U.1 T2J.1
Piping classes P-1, P-2, P-LT	7/ 8/ 10/ 11/	P-3 P-8 P-13 P-68 P-74 P-4 P-9 P-14 P-70 P-75 P-5 P-10 P-15 P-71 P-76 P-6 P-11 P-17 P-72 P-77 P-7 P-12 P-67 P-73

See footnotes at end of table.

Original 82

TABLE VII. Approved weld joint designs. 1/ - Continued

Service classification	Approved joint efficiencies and notes 14/	Joint identification numbers (MIL-STD-22)
Piping class P-2	9/ 10/ 12/ 13/	P-1 P-61 P-2 P-62 P-16 P-63 P-42 P-64 P-60 P-66
Steam turbines class T-1	Welded joints shall be full penetration (see MIL-STD-22 for guidance)	
Steam turbines class T-2	Joint designs of the same types used for previous Navy turbines are acceptable. New joint designs, not proven in service, shall be reviewed and commented on by NAVSEA prior to production application. MIL-STD-22 may be used for guidance.	

- 1/ The application of the listed joint designs to a specific service classification is subject to the applications and limitations of MIL-STD-777 for surface ships and MIL-STD-438 for submarines.
- 2/ These joints may be used when specifically approved.
- 3/ Pressure vessel joints: Welded joints for all pressure vessels shall be of 100 percent efficiency (see 9.3). Circumferential and longitudinal joints shall be welded from both sides or consumable inserts or backing strips shall be used to assure complete weld penetration. Welds shall be made with multiple layers of deposited metal.
- 4/ Welded joints for openings in class A-1, A-2, A-F, and A-LT pressure vessels including nozzles, handholes, manholes, or other penetrations of sizes 2-1/2 inch nps and greater shall be of a design and in a location which permits radiography in accordance with MIL-STD-271.
- 5/ Butt welding plates of unequal thicknesses shall be in accordance with the applicable figure of MIL-STD-22.
- 6/ The joints listed are applicable to welds in the pressure containing envelope of the vessel except for systems subject to submergence pressure where welds shall be full penetration. The designer is not limited to these joints or 100 percent efficiency requirement for internal or external structural attachments except where required by component or system specifications.

- 7/ Class P-1 piping butt joints shall be designed, welded, and inspected to assure complete weld penetration. P-1 piping butt joints in submarine seawater systems shall be the consumable insert type except that backing rings may be used for closure welds where allowed by drawings or specifically approved. Joint P-73 may have $\theta = 45$ degrees plus or minus 5 degrees for copper-nickel seawater systems. Joints P-13, P-14, and P-15 shall be limited to 2-inch nps and smaller for class P-1 piping systems (except that socket weld designs shall not be used in systems where 100,000 or more cycles of pressure variation, of more than 2/3 normal operating pressure, are expected) and a reference mark suitably located shall be established as a benchmark for verifying fillet weld size by an appropriate gauge measuring device.
- 8/ Joints such as P-3, P-13, P-14, and P-15 shall not be permitted on materials subject to crevice corrosion except as permitted by footnote 10.
- 9/ Except as permitted by footnote 10, joints such as P-1, P-2, P-12, P-60, P-61, P-62, P-67, and P-68 shall not be permitted on materials subject to crevice corrosion unless the inside surface of the weld is visually inspected to assure complete weld penetration.
- 10/ Joints addressed by footnotes 8 and 9 are satisfactory for use in seawater service when the material of fitting and pipe is copper-nickel, 70-30 or 90-10 alloys or a combination of both.
- 11/ P-67 joint and P-68 joint 4 inches and smaller welded from one side only may be used for class P-1 where the following conditions are met:
- (a) Branch connection fit-up, welding processes, and final inspection ensures complete root penetration and an acceptable weld contour on inner surface. Welding of such joints requires separate welding procedures and welder qualifications in accordance with MIL-STD-248.
 - (b) The PT or MT (as applicable) inspection methods shall be used for the root weld layer and both final weld surfaces. Visual examination at 5X magnification may be substituted for MT/PT of the root weld pass in the grooved side.
- 12/ P-42 joints shall not be used with butterfly valves, spiral wound gaskets, or flanged joints in oil systems.
- 13/ Unreinforced branch connections such as P-60, P-61, P-62, P-63, and P-64 joints shall not be used in any systems where the design gauge pressure is over 150 lb/in² or the design temperature is over 449°F. Reinforcement shall not be obtained by weld buildup and any branch connection fabricated by the use of welding only shall be considered as unreinforced.
- 14/ See 9.3.2.1.

9.3 Joint efficiency. The efficiency of a welded joint shall be based on the minimum tensile strength of the weaker member where the weaker member is defined to be the member whose product of thickness times its minimum tensile strength has the lower value.

9.3.1 Fillet welds.

9.3.1.1 Continuous double fillet tee or continuous double fillet lap welded joints. When it is necessary to calculate the size, strength, or efficiency of a continuous double fillet welded tee or lap joint, the resulting data shall be considered as the allowable ultimate design values regardless of the direction of application of the load. The sizes, strength, and efficiencies of double fillet welds shall be determined by using the applicable formulas and the appropriate filler metal shear strength data of MIL-STD-1628.

9.3.1.2 Fillet joints welded all around. For those cases where the fillet weld is continuous around the ends of the member; such as in the case of a round or rectangular tube, bar, or rod whose end is welded to a plate or similar member; the weld shall be sized to develop the strength required by the design. Calculations for the sizes, strengths, and efficiencies of these joints shall be made in accordance with MIL-STD-1628, giving full credit for the length and location of the fillet and the sectional properties of the tube, bar, rod, and so forth.

9.3.2 Joints other than fillet welds.

9.3.2.1 Full penetration joints. Full penetration welds, where compatible weld metal of equivalent or greater ultimate tensile strength is used, are considered to be 100 percent efficient welds. For welds made with MIL-120 and MIL-140 series filler materials, joint efficiencies of welds in thin material (where at least one member is less than 3/4 inch thickness) shall be modified to account for the reduced strengths of as deposited filler materials which occur in these low cooling rate applications (see 6.5).

9.3.2.1.1 Full penetration joints welded from both sides. Full penetration joints welded from both sides shall have the root layer back-gouged, chipped, ground, or machined to sound metal prior to welding the second side; however, joints may be welded without such cleaning when qualified procedures and techniques (such as twin arc and submerged arc) are approved for such application.

9.3.2.1.2 Full penetration joints welded from one side. Full penetration joints welded from one side only without backing bars or consumable inserts may be rated 100 percent efficient when fabricated using a qualified welding procedure. Joints of this type not conforming to the above shall be rated at efficiency values which do not exceed 80 percent.

9.3.2.2 Partial penetration joints. Where partial penetration welded joints are required, the weld shall be sized to develop the strength required by the design.

9.3.2.2.1 For class M-2 and class A applications, the thickness limitations of MIL-STD-22 do not apply.

9.3.2.2.2 Joints within the same design group may be interchanged without drawing changes provided weld joint efficiencies are not reduced.

9.3.2.2.3 Full penetration joint designs may be used where partial penetration joint designs are specified provided the required joint efficiency is maintained. When this is done, the inspection requirements for the partial penetration joint design apply.

10. INSPECTION REQUIREMENTS

10.1 General. This section contains the minimum requirements for inspection of welded joints in machinery, piping, and pressure vessels. This section is not applicable to components listed in sections 12, 13, 14, and 15.

10.2 Performing NDT. NDT shall be performed in accordance with MIL-STD-271. When RT is specified and the geometry of the part or weld is such that RT is not technically practical, an alternate inspection system shall be approved by NAVSEA. Where MT or PT inspection methods are applied, both root (backside when accessible) and finished weld surface shall be so inspected. Pneumatic testing may be used in lieu of hydrostatic testing (for pressure test) for pneumatic systems.

10.3 Extent of inspection and methods.

10.3.1 Class M machinery. Welded joints in class M machinery components, except welded joints in turbines and propulsion and auxiliary gears (see sections 13 and 14), shall be inspected as specified in table VIII.

TABLE VIII. Class M machinery inspection requirements.

Machinery class	Category	Welded joint type	Required examinations and tests					
			VT <u>7/</u>		MT/PT test <u>6/</u>		RT <u>4/</u>	
			Root layer	Final weld	Root layer	Final weld	Final weld	Extent
M-1	A	Butts	-	X	X <u>1/</u>	X <u>2/</u>	X	100 percent
		All others	-	X	X <u>1/</u>	X <u>2/</u>	<u>3/</u>	-
	B	All	-	X	X <u>1/</u>	X <u>2/</u>	<u>3/</u>	-
	C	All	X	X	-	<u>3/</u>	-	-
M-2	A	All	-	X	X <u>1/</u>	X <u>2/</u>	<u>3/</u>	-
	B	All	-	X	X <u>1/</u>	X <u>2/5/</u>	-	-
	C	All	X	X	-	<u>3/</u>	-	-

NOTE: X indicates that the test is required.

1/ For joints welded from one side only, MT/PT inspect the root pass. For double welded joints, MT/PT inspect the backchipped, gouged, ground, or machined root area prior to welding the second side. VT at 5X magnification may be substituted for MT/PT inspection. Linear discontinuities shall be unacceptable. Root layer inspection may be deleted if the weld is given a 360 degree (or 100 percent) RT or UT inspection.

- 2/ When post weld heat treatment or stress relief is performed, this inspection shall be accomplished after heat treatment or stress relief. Where accessible, the inner face shall be MT/PT inspected and the inspection shall be performed after any machining operations.
- 3/ Inspection required when specified in drawing, shipbuilding, or component specification.
- 4/ UT may be substituted for RT when approved.
- 5/ For Class M2, category B welds in Ship Stores Refrigeration Plant, structural components of S-1 materials, VT of the final weld may be substituted for the required MT inspections.
- 6/ See 10.3.12.
- 7/ See 10.3.13 for S-51, S-52, and S-53 material welds.

10.3.2 Class P piping. Welded joints in class P piping systems shall be inspected as specified in table IX.

TABLE IX. Class P piping inspection requirements. 1/ 2/

Piping class	Welded joint type	Pipe size, inches nps	Required examinations and tests						
			VT 18/		MT/PT test 17/		RT		Pressure 11/
			Root layer	Final weld 16/	Root layer	Final weld 5/	Final weld 3/	Extent 15/	
Lethal or gasoline	Butt	All	-	X	X 4/	X	X	360 deg.	X
P-1 and P-LT 12/	Butt	>3-1/2	-	X	X 4/	X	X 13/	360 deg.	X
		2-1/2 to 3-1/2 inclusive	-	X	X 4/	X	X 6/ 7/ 13/	60 deg. min.	X
		<2-1/2	-	X	X 4/	X	X 6/ 7/ 8/ 9/ 13/	60 deg. min.	X
	Sockets, fillets 14/, and other attachments	All	-	X	X 4/	X	-	-	X

TABLE IX. Class P piping inspection requirements. 1/ 2/ - Continued

Piping class	Welded joint type	Pipe size, inches nps	Required examinations and tests						
			VT <u>18/</u>		MT/PT test <u>17/</u>		RT		Pressure
			Root layer	Final weld <u>16/</u>	Root layer	Final weld <u>5/</u>	Final weld <u>3/</u>	Extent <u>15/</u>	<u>11/</u>
P-2	Butt	2-1/2 and >	-	X	-	<u>10/</u>	<u>10/</u>	-	X
		<2-1/2	-	X	-	<u>10/</u>	-	-	X
	Sockets fillets and other attachments	All	-	X	-	<u>10/</u>	-	-	X

NOTE: X indicates that the test is required.

- 1/ This table does not apply to piping used in components or accessories covered in sections 13, 14, and 15, which specifically list inspection requirements.
- 2/ Where new welds in piping intersect existing or older welds, the latter welds shall be inspected for a distance of 6 inches or a distance equal to 50 percent of the pipe size diameter, whichever is less, as measured from points of intersection. Acceptance criteria for the existing or older welds and adjacent base metal shall be the same as that specified by MIL-STD-2035 for inadvertent radiography.
- 3/ For the following applications or systems, MT or PT may be substituted for RT provided the inspection requirements of footnote 4 are met:
- Piping for gas turbine and diesel engine exhaust system, except that section in submarines between the inboard and outboard exhaust valves which is subject to submergence pressure.
 - Incinerator up-takes.
 - Exhaust relief valve which dumps to the bilge or the atmosphere.
 - Trim and drain pump suction piping welds which are not in the reactor compartment.
- 4/ For joints welded from one side only, MT/PT inspect the root pass. For double welded joints, MT/PT inspect the back chipped, gouged, ground, or machined root area prior to welding the second side. VT at 5X magnification may be substituted for MT/PT inspection except for boiler tube to drum joints and superheater tubes to header joints. Linear discontinuities shall be

unacceptable. Root layer inspection may be deleted if the weld is given a 360 degree (or 100 percent) RT or UT inspection. Root layer inspection is not required for welds, such as bosses and removable backing, where the root layer will be removed.

- 5/ The outer surface and, when accessible, the inner surface shall be MT/PT inspected, and the inspection shall be performed after machining operations. When postweld heat treatment or stress relief is performed, this inspection shall be accomplished after heat treatment or stress relief.
- 6/ RT of welds on piping in the horizontal fixed position shall represent a sector which was welded in the vertical or overhead position.
- 7/ In lieu of 60-degree RT, PT or MT may be performed on the inside of a joint where the weld is within 2-1/2 nominal pipe diameters from the open end and is back welded, has backing ring removed, or used consumable insert.
- 8/ Welds in boiler generating tubes and economiser elements, and external superheater tube-to-header stub welds may be MT or PT inspected in lieu of RT. For safe end welds and other welds in superheater tubes (support tubes excluded), sample RT inspection in accordance with NAVSEA 0910-LP-331-5300 may be performed in lieu of RT of each weld.
- 9/ RT is required only when the design pressure exceeds 575 lb/in². For design pressure of 575 lb/in² and less, only MT or PT inspection is required.
- 10/ PT inspection shall be required for seawater systems in submarines on completed P-70 through P-72 type copper-nickel welds as defined in MIL-STD-22. Other systems shall require MT/PT and RT only when specified in the shipbuilding or component specification.
- 11/ (a) Refer to the applicable system or component specifications for tests requirements. Testing shall be conducted on uncoated piping welds.
(b) For repairs to systems that have passed a hydrostatic test, rehydrostatic test is not required where repairs do not exceed 3/16 inch or 20 percent of base metal thickness, whichever is less. This exception does not apply if the repair weld is subjected to post weld heat treatment.
- 12/ For class P-LT piping constructed of cryogenic compatible materials such as aluminum alloys or 300 series stainless steel, the inspection requirements shall be as follows:
 - (a) Butt joints and other full penetration welds - 60 degrees minimum shall be subjected to RT in addition to VT and PT inspection.
 - (b) Socket welded joints and other partial penetration joints - VT and PT inspection.

- 13/ For hydraulic systems, RT is required only when the design pressure exceeds 600 lb/in².
- 14/ Includes boiler tube to drum joints and superheater tube to header joints.
- 15/ Where unacceptable defects in pipe welds are located by partial radiography, the entire circumference of these welds shall be radiographed.
- 16/ See footnote 9 of table VII.
- 17/ See 10 3.12.
- 18/ See 10.3.13 for S-51, S-52, and S-53 material welds.

10.3.3 Class A pressure vessels and class T turbines. Welded joints in class A pressure vessels shall be inspected as specified in table X, except welds in forced draft blowers shall be inspected in accordance with section 16. Welds in class T turbines shall be inspected in accordance with section 14.

TABLE X. Class A pressure vessel inspection requirements. 1/

Pressure vessel class	Weld joint type	Required examination and tests						
		VT <u>10/</u>		MT/PT test <u>9/</u>		RT		Pressure
		Root layer	Final weld	Root layer	Final weld <u>7/</u>	Final weld <u>7/</u>	Extent <u>8/</u>	<u>2/</u>
A-F A-1 A-2	Butt and other complete penetration welds	X	X	X <u>3/</u>	X <u>4/</u>	X	100 per-cent of all long. and circ. welds	X
A-F A-1 A-2	Nozzles 2-1/2 inches and greater	X	X	X <u>3/</u>	X <u>4/</u>	X	360 deg.	X
	Nozzles less than 2-1/2 inches, pads and other attachments	-	X	X <u>3/</u>	X <u>4/</u>	-	-	X

See footnotes at end of table.

TABLE X. Class A pressure vessel inspection requirements. 1/ - Continued

Pressure vessel class	Weld joint type	Required examination and tests						
		VT 10/		MT/PT test 9/		RT		Pressure 2/
		Root layer	Final weld	Root layer	Final weld 7/	Final weld 7/	Extent 8/	
A-3 A-LT	Butt and other complete penetration welds	-	X	X 3/	X 4/	X 5/ 6/	10 percent of all long. and circ. welds	X
	All nozzles, pads, and other attachments	-	X	X 3/	X 4/	-	-	X
A-4	Butt and other complete penetration welds	X	X	-	-	-	-	X
	All nozzles, pads, and other attachments	X	X	-	-	-	-	X

NOTE: X indicates that the test is required.

- 1/ Where new welds in pressure vessels intersect or terminate on existing or older welds, the latter welds shall be RT inspected for a distance of 6 inches (each side of intersection), measured from the point of intersection. Acceptance criteria for the existing or older welds and adjacent base metal shall be the same as that specified by MIL-STD-2035 for inadvertent radiography.
- 2/ Welded vessels shall be subjected to hydrostatic pressure test in accordance with the requirements for pressure vessels of their type and held for sufficient time to permit VT of all welds. Pressure tests shall be conducted on uncoated pressure vessels.
- 3/ For joints welded from one side only, MT/PT inspect the root pass. For double welded joints, MT/PT inspect the back chipped, gouged, ground, or machined root area prior to welding the second side. VT at 5X magnification may be substituted for MT/PT inspection. Linear discontinuities shall be unacceptable. Root layer inspection may be deleted if the weld is given a 360

degree (or 100 percent) RT or UT inspection. Root layer inspection is not required for welding such as bosses and removable backing, where the root layer will be removed.

- 4/ The outer surface and, when accessible, the inner surface shall be MT/PT inspected, and the inspection shall be performed after any machining operations. When post weld heat treatment or stress relief is performed, this inspection shall be accomplished after heat treatment or stress relief.
- 5/ Where both longitudinal and circumferential weld joints are used, the intersection of these welds shall be included in the 10 percent radiographed.
- 6/ RT is not required when the nominal operating pressure does not exceed 125 lb/in², even though the relief valves are set at gauge pressures greater than 150 lb/in².
- 7/ For HY/HSLA and STS final weld inspection shall be performed no sooner than the following:
 - RT (butt welds only): a minimum of 8 hours after reaching ambient temperature.
 - MT (all welds): a minimum 24 hours after reaching ambient temperature.
- 8/ Where unacceptable defects in pressure vessel welds are located by partial radiography, the entire length of these welds shall be radiographed.
- 9/ See 10.3.12.
- 10/ See 10.3.13 for S-51, S-52, and S-53 material welds.

10.3.4 Repaired welds. Completed weld repairs of weld defects, if required as specified in 7.7, shall be inspected by the same nondestructive method required for the original weld. Where additional weld metal has been deposited on the surface of previously accepted RT or UT welds and finished repair weld thickness does not exceed 3/16 inch or 20 percent of base metal thickness, whichever is less, the finishing layer may be inspected by the MT or PT method. The acceptance criteria shall be those specified for the weld class involved.

10.3.5 Base metal repair. Surface defects and damaged base material may be repair welded provided the repair weld and adjacent metal is inspected by the same methods as required for the class of welding. Excavations on the pipe within the socket bore depth of socket welds are not required to be repaired. Excavations in way of the fillet weld of socket welds may be restored during welding of and considered part of the fillet weld. Weld repairs not in excess of those defined for minor casting repair (see 13.2.2) can be made on wrought material at the discretion of the fabricator provided all requirements of this document are met. More extensive weld repairs shall require approval except that no approval shall be required for repairs made with an approved standard repair procedure including welding parameters, inspection, and record requirements meeting all the requirements

specified herein and in MIL-STD-248. Where RT is a requirement for the class of welding, MT or PT may be used in lieu of RT where finished weld thickness does not exceed 3/8 inch or half the design thickness of the base material, whichever is less. In addition, where RT would normally be required for the class of welding involved and the repair falls within a non-fluid boundary area (such as misdrilled flange bolt holes and so forth), case basis approval to delete RT may be obtained from the authorized representative. Repairs on P-1, P-LT, A-1, A-2, A-3, A-F or A-LT components shall be documented and records maintained available to the authorized representative for review. These repair records shall include the following: name and identification of component; description of defects repaired (location, length, width, and depth of excavation); base material; welding filler metal; post heat treatment (where applicable); and final inspection results.

10.3.5.1 Arc strikes and removal sites of welded attachments shall be ground to fair smoothly into base material surfaces. Where grinding reduces thickness below design requirements, areas shall be restored by welding and grinding. Finish ground areas, whether repair welded or not, shall be inspected by MT, PT, or VT at 5X magnification where any of the following apply: weldment is class P-1, P-LT, A-1, A-2, A-3, A-F, or A-LT; or base material is S-1 (with carbon content 0.35 percent or greater), S-3, S-3A, S-4, S-5, S-6, S-6A, S-11, S-51, S-52 or S-53.

10.3.5.2 Base metal weld repairs of class P-3 brazed piping system components shall be inspected in accordance with 10.3.5 using the appropriate equivalent welded piping system classification (P-1, P-2, or P-LT) for the system after matching the brazed piping system fluid, operating pressure, and operating temperature to the equivalent welded piping system classification for those system conditions.

10.3.5.3 Where buildup by welding in a joint to correct oversize root openings or errors in joint preparation is accomplished, it should be done prior to fitting and unless specifically approved otherwise, such buildup of each joint edge shall not exceed 1/2T or 1/2 inch, whichever is less (where T is the thickness in way of the weld buildup member being welded). The buildup allowed for both joint edges may be applied to one joint edge.

10.3.6 Weld deposited cladding, hardsurfacing, and buttering. Weld deposited cladding or hardsurfacing shall be VT and PT inspected; acceptance criteria shall be in accordance with 10.4.2. Buttering shall be inspected by MT or PT method, as applicable. Where joint edges are buttered prior to joint welding and the joint requires RT inspection, the buttered edges shall also require RT inspection. The buttered area and the completed weld can be radiographed at the same time. Where MT or PT inspection of the completed joint is required, all exposed surfaces of the buttered area shall also be inspected during the inspection of the finished weld joint. In addition, weld deposited buttering that forms part of a pressure boundary subject to submergence pressure shall also require UT inspection to detect defects and lack of bond prior to joint welding. UT inspection shall be in accordance with MIL-STD-271 as modified by 10.4.4.1. Acceptance criteria shall be in accordance with 10.4.4.2.

10.3.7- Loss of preheat and interpass. Welds for which the preheat and interpass temperature is permitted to drop below temperatures specified in table IV

before completion shall require reheating as necessary, prior to resumption of welding. Partially completed welds shall be MT inspected prior to resumption of welding when ferromagnetic filler material is used and the following conditions of temperature drop occur:

- (1) For S-3A, S-4, S-5, S-6 and S-7, temperature drop is more than 100°F below the minimum specified in table IV.
- (2) For S-11A 1 1/8" and thicker, material temperature decreases to less than 100°F.
- (3) For S-11B 5/8" and thicker, material temperature decreases to less than 100°F for GMAW and 150°F for SMAW.

Inspection records are not required. For loss of preheat and interpass temperatures when using MIL-120 or MIL-140 series filler material, paragraph 6.5.1 shall apply.

10.3.8 Tack welds. Tack welds to be incorporated into the final weld shall be visually examined and defects, such as cracks, excessive undercut, entrapped slag, and excessive surface roughness, shall be corrected to the extent necessary to assure that final weld quality requirements will be met. All cracks shall be removed except cracked or broken tack welds need not be removed provided: (a) they were made by the GTA process, (b) they will not permit movement of joint components which causes the joint to exceed fit-up requirements, (c) they will be completely re-melted in deposition of the first layer, and (d) the first layer is made by the GTA process.

10.3.9 Seal welds. The final layer of seal welds shall be inspected by the PT method if MT/PT is required for the class of welding for the system involved or is specified by governing equipment or system specification. Other system seal welds shall be visually inspected.

10.3.10 Substitution of VT inspection. VT inspection at a magnification of 5X may be performed in lieu of PT inspection within 1/4 inch of open ends of welds or repairs to the root layer of partial penetration welds which would permit entrapment of penetrant materials.

10.3.11 Non-structural welds. Non-structural welds covered by 6.1.2 shall be MT, PT or 5X visual inspected to assure freedom from cracks.

10.3.12 MT inspection for MIL-140S, MIL-120S and MIL-12018 welds in class A-F, A-1, A-2, A-LT, P-1, P-LT and M-1 (Category A and B). Final MT of MIL-120S and MIL-12018 butt welds in Class A-F, A-1, A-2, A-LT, P-1, P-LT and M-1 (Category A and B) shall be performed in accordance with the additional MT requirements for Class I.A.1 butt welds as specified in MIL-STD-1688. For MIL-140S welds additional MT requirements shall be as approved by NAVSEA.

10.3.13 Titanium and titanium alloy welds. The final surface of titanium and titanium alloy welds including the inner surface of any weld or weld repair, when

accessible shall be inspected for color in the "as-deposited" condition by a qualified VT inspector. Use of borescopes is not required.

10.4 Acceptance standards.

10.4.1 Visual examination. Acceptance of completed welds subjected to visual examination shall be based on conformance with the document and class requirements specified in table XI.

TABLE XI. Acceptance standards and classes.

Weld application ^{1/}	MIL-STD-2035 VT ^{5/} and MT/PT ^{2/ 4/}	MIL-STD-2035 RT	MIL-STD-2035 UT
	Class	Class	Class
Class M-1	2	2	2
Class M-2	3	<u>3/ 3</u>	3
Class P-1, P-LT	1	1	-
Class P-2	2	<u>3/ 2</u>	-
Class A-1, A-2	1	1	-
Class A-3, A-4	2	<u>3/ 2</u>	-
Class A-F, A-LT	1	1	-

- ^{1/} Where unacceptable defects in pipe welds are located by partial radiography, the entire circumference of these welds shall be radiographed. For other applications of partial radiography, where defects in excess of the standard are found, the welds shall be radiographed until the full extent of defective welding has been located.
- ^{2/} In general, MT shall be used on ferrous materials and PT on nonferrous and austenitic corrosion resisting steels.
- ^{3/} Acceptance is to be based on conformance with the requirements of the indicated class where the specific inspection method is required by a governing component or equipment specification.
- ^{4/} PT shall not be used on weld beads in S-51, S-52, and S-53 materials that will be welded over unless a crack is detected by VT and shall then only be used in the limited area of the crack to explore its removal. All traces of the penetrant must be removed from the joint before welding over.
- ^{5/} Prior to any cleaning, brushing, etc., intermediate and final weld surfaces, including inner weld surfaces, of S-51, S-52, and S-53 materials shall be as follows:

- (a) Welds and surrounding 1/32 inch of material shall exhibit a bright, shiny, silvery luster. Other conditions are unacceptable and shall be dispositioned as follows: Loss of luster or colors other than straw (e.g., purple, blue, yellow, gray, etc.) shall require complete removal of the affected weld bead along with 1/16-inch minimum of surrounding material. Straw color on surfaces to be welded over shall be removed prior to further welding. Straw color does not require removal from final weld surfaces.
- (b) For areas beyond 1/32 inch from the weld toes. All discoloration on surfaces to be welded over is unacceptable and shall be removed prior to further welding. Colors except for straw on other surfaces shall be removed. Removal may occur after completion of welding.

10.4.1.1 General. VT inspection shall be performed using a written procedure and qualified personnel in addition to the requirements of MIL-STD-271. VT inspection qualification and training shall be documented in a written procedure. VT inspection shall be accomplished without the use of magnifying glasses or other visual aids except for corrective aids to restore normal vision.

10.4.1.2 Welds. VT inspection of welds shall be performed after slag removal and with the weld in the final surface condition. For welds in S-51, S-52, and S-53 materials VT inspection for color (contamination) shall be in the as-welded condition before wire brushing or any other cleaning. After correction of unacceptable color condition, a final visual inspection for color shall be performed.

10.4.1.3 Base material. The surface to be inspected shall be in a clean condition. Surfaces which have been cleaned and painted with one coat of primer are considered suitable for inspection.

10.4.2 MT and PT inspection. Acceptance of welds and the adjacent base metal subjected to MT or PT inspection shall be in accordance with the standard and class requirements specified in table XI. Acceptance criteria for cladding or weld overlay shall be in accordance with the class specified for the weld application; however, where weld cladding is used to provide corrosion resistance for gasket seats or similar applications, the following acceptance criteria apply:

- (1) O-ring or gasket seating surfaces plug 1/8 inch to either side of the designed gasket location or line of contact -- class 1.
- (2) Other cladding normally subjected to liquid pressure -- class 2.
- (3) Other cladding normally dry (for example, on the low pressure side of the gasket) -- class 3.

10.4.2.1 Adjacent casting base material. PT indications in casting base material adjacent to fabrication welds may be evaluated as follows:

- (1) Castings requiring PT inspection in accordance with the footnotes to the tables in section 12 may be evaluated to the applicable casting acceptance standard.
- (2) Castings not requiring PT inspection in accordance with the footnotes to the tables in section 12 may be evaluated in accordance with 13.2.8.2.1.

10.4.3 Radiography. Radiographs for welds shall be compared with the standard for radiography and classes in accordance with table XI.

10.4.4 UT inspection. Acceptance of welds subjected to UT inspection shall be in accordance with the applicable standard and classes specified in table XI.

10.4.4.1 UT inspection of weld deposited buttering. Prior to UT inspection of the weld deposited buttering for defects and lack of bond, the test equipment shall be calibrated by using a calibration block which has been fabricated by buttering using the same process, filler metal, and base metal as the production part. (Equivalent S number base metal may be used. For this purpose, S-1, S-2, S-3, S-4, S-5, and S-11 material are considered equivalent.) Calibration block shall have equivalent weld thickness and surface finish as the production part and shall be sufficiently thick to accommodate the required calibration holes needed to establish the distance amplitude correction (DAC) curve.

10.4.4.1.1 Calibration for inspecting weld deposited buttering for both weld metal defects and lack of bond.

(a) Holes shall be drilled into the block as follows:

Either 1/8-inch diameter flat bottomed holes shall be drilled from the base metal side with their axes perpendicular to the sound beam entry surface or 1/16-inch diameter holes at least 1-1/2 inches long shall be drilled parallel to the sound beam entry surface. The holes shall be positioned so that the following test metal distances (TMD) from the sound beam entry surface to the nearest surface of a hole are obtained:

(1) Deposited thickness up to and including 1/2 inch:

- 1/16 inch TMD
- (T/2) TMD \pm 1/32 inch
- (T) TMD \pm 1/16 inch

Where T = Deposited thickness or 1/2 inch, whichever is less.

For deposits less than 7/16 inch thick, the T/2 TMD hole may be omitted.

(2) Deposited thickness (T) over 1/2 inch:

- 1/2 inch TMD
- (T/2 inch + 1/4 inch) TMD \pm 1/32 inch
- (T) TMD + 1/16 inch

For deposits greater than 1/2 inch and less than 1 inch, the (T/2 + 1/4 inch) TMD hole may be omitted.

All holes in the test block shall be separated sufficiently to preclude acoustic or mechanical interference with calibration.

- (b) In the case of deposited metal 1/2 inch or less in thickness, the test equipment shall be adjusted to provide an indication 85 to 90 percent of full screen height from the hole at T/2 TMD. At this equipment setting, the signal amplitudes received from the other two holes shall be marked on the screen and all three signals shall be connected by means of straight lines to provide a DAC curve. If the T/2 TMD hole is omitted, the test equipment shall be adjusted to provide an indication 85 to 90 percent of full screen height from the hole which reflects the greatest signal amplitude. The peaks of the signals received from the two holes will be connected by a straight line to form the DAC. In the case of deposited metal thicker than 1/2 inch, the test equipment shall be adjusted to provide an indication 85 to 90 percent full screen height from the hole which reflects the greatest signal amplitude. At this equipment setting, the indications from the remaining holes (or hole) shall be marked on the screen and a DAC curve made. When inspecting production hardware, the first 1/2 inch of weld deposited metal shall be evaluated using the DAC curve specified in (a)(1) and the remaining thickness shall be evaluated using the DAC curve specified in (a)(2). The horizontal sweep shall be adjusted so that the position of the indication from the calibration hole at TMD + 1/16 inch is at least 25 percent of full screen width.

10.4.4.2 Acceptance criteria for weld defects and lack of bond in weld deposited buttering:

- (a) Indications greater than the DAC curve specified in 10.4.4.1.1 are unacceptable.
- (b) Indications greater than 50 percent of the DAC curve and longer than that permitted by figure 2 are unacceptable.
- (c) Separate indications greater than 50 percent of the DAC curve shall be separated by a minimum distance of 2 inches in any direction.
- (d) Indications greater than 50 percent of the DAC curve shall be recorded on the UT report as to amplitude, extent, and location.

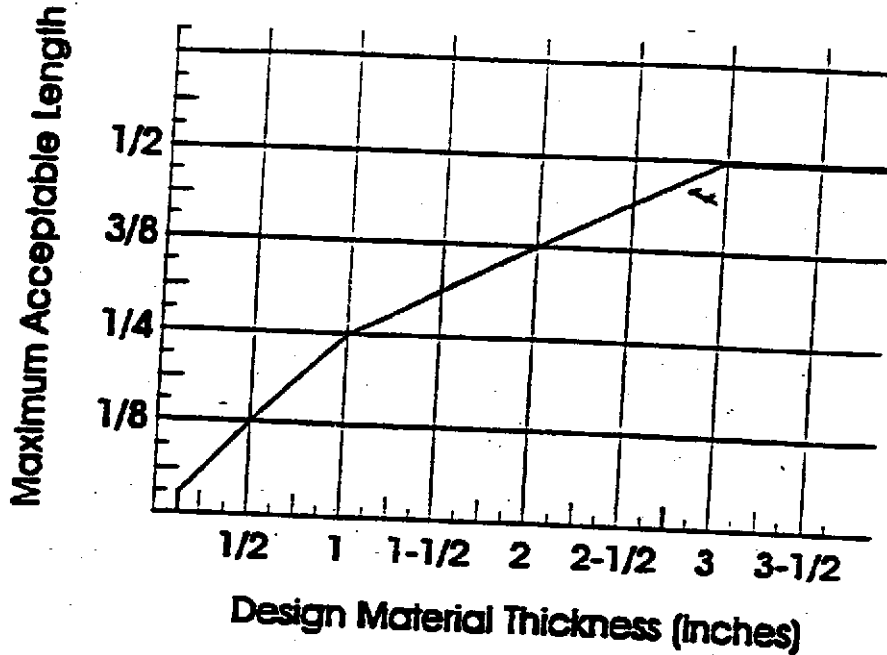

FIGURE 2. Maximum acceptable ultrasonic indication length for weld deposited buttering.

10.5 Disposition of rejected welds. Welds not meeting the specified acceptance criteria shall be rejected until repaired and reinspected to the applicable criteria.

10.6 Hardness testing of titanium and titanium alloy flame cut surfaces. Hardness testing using a portable hardness tester shall be conducted on conditioned surface at approximately 6 inches interval to ensure that all contaminated metal has been removed. Hardness of the conditioned cut surface shall be not more than three points Rockwell C higher than that of the base material taken as an average of ten readings, at a minimum of 1 inch from the cut surface.

11. ALLIED PROCESSES

11.1 General. This section contains the minimum requirements for welding processes allied to those processes used for welded joints.

11.2 Thermal spraying. Thermal spraying for purposes other than providing corrosion protection by aluminum shall be in accordance with MIL-STD-1687. Thermal spraying for corrosion protection by aluminum shall be in accordance with DOD-STD-2138.

11.3 Thermal cutting. Thermal cutting may be employed in the preparation of plates, piping, and fabrication subject to the restrictions specified herein. Carbon steels and low alloy steels having a carbon content less than 0.35 percent may be oxyfuel gas cut. Higher alloy steels shall not be oxyfuel gas cut. Wherever practicable, machine thermal cutting shall be used to cut materials greater than 1/2 inch in thickness. After cutting, all scale and slag on the cut surfaces shall be removed by mechanical means prior to further fabrication or use. The discoloration which may remain on the cut surface is not considered to be detrimental oxidation. Thermal cut surfaces to be welded shall not contain gouges or other irregularities detrimental to making of sound welds. Preheating, as necessary, shall be done to avoid cracking.

11.3.1 Titanium and titanium alloys. Thermal cut surfaces of S-51, S-52, and S-53 materials shall be conditioned by removing a 1/8-inch minimum of material, beyond the kerf, from the cut surfaces by saw cutting, burring or machining and preparing the weld joint per 7.2.2. The conditioned thermal cut surface shall be inspected visually with 5X magnification prior to wire brushing to ensure absence of cracks and shall be hardness tested per 10.6.

11.4 Resistance welding. Resistance welding shall be performed with automatically-timed machinery capable of producing welds of acceptable strength, ductility, and corrosion resistance. Qualification of both procedure and equipment shall be required before any production work is undertaken. The strength, location, and spacing of the welds proposed shall be clearly shown on the drawings submitted for acceptance. Welding shall be in accordance with MIL-W-6858.

11.5 Stud welding.

11.5.1 General. Automatic timed arc or percussive (capacitor discharge) welded studs for all permanent applications shall be inspected at the beginning and end of each set-up (diameter change) or shift operation by bending or torque testing five consecutively welded studs.

11.5.1.1 Bend testing. If bend testing is performed, the studs to be tested shall be welded to a piece of material of the same S-group thickness and position as the production application. Bending of production studs is prohibited. Studs shall be bent to an angle of 15 degrees and return using a device similar to that shown on figure 3.

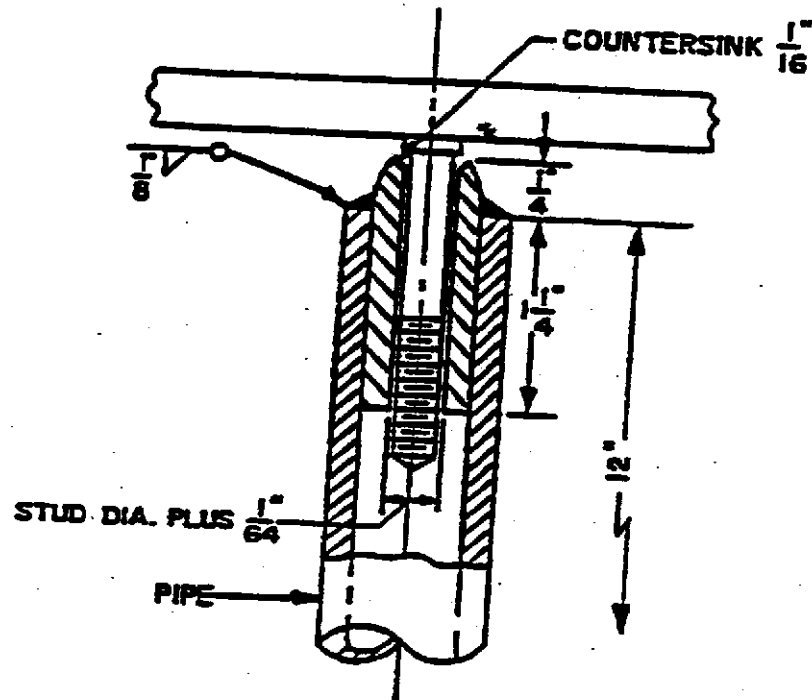

SH 9320

FIGURE 3. Device for testing welded studs.

11.5.1.2 Torque testing. Studs shall be tested by torquing until a tensile load equivalent to 80 plus 10 or minus 0 percent of the yield strength of the stud material is applied. Production studs shall be tested. The stud cross section at the stud base or root of the threads, whichever is less, shall be used as the basis for determining the required load. Any convenient means, such as placing a sleeve and washer over the stud and tightening a nut with a calibrated torque wrench, may be used to achieve the required axial load. To ensure that the weld is loaded primarily in tension, the stud threads and nut-washer interface shall be clean, free of burrs and lubricated with a graphite base, or a comparable lubricant (do not use molybdenum disulfide on studs of (or studs welded to) high strength low alloy steels such as 4140, 4340, HY/HSLA, where stress corrosion cracking might occur). The tensile loads and torque values specified in Table XII shall be used when the listed yield strengths and dimensions apply.

Table XII. Torque-tension minimum values (80 percent of yield strength).

		Carbon steel & stainless steel (35 klbs/in ² yield strength)		UNS N06625 (60 klbs/in ² yield strength)		Aluminum (15 klbs/in ² yield strength)	
Stud Size and Thread Class	Minor Thread Diameter	Axial Load	Torque	Axial Load	Torque	Axial Load	Torque
UNC, UNF NC/NF Class 2A	Inches	lbs	Inch-lbs	lbs	Inch-lbs	lbs	Inch-lbs
10-24	0.1379	417	9	715	15	179	4
10-32	.1508	501	11	859	19	215	5
1/4-20	.1876	773	22	1325	37	331	9
1/4-28	.2052	927	29	1588	49	397	12
5/16-18	.2431	1299	47	2227	81	557	20
5/16-24	.2603	1490	58	2553	100	638	25
3/8-16	.2970	1940	86	3326	149	882	37
3/8-24	.3228	2290	111	3926	190	982	48
7/16-14	.3485	2761	144	4579	239	1145	60
7/16-20	.3749	3091	174	5299	298	1325	75
1/2-13	.4041	3590	218	6153	373	1538	93
1/2-20	.4374	4208	276	7214	473	1804	118
5/8-11	.5119	5762	442	9878	759	2470	190
5/8-18	.5554	6784	565	11630	969	2908	242
3/4-10	.6255	8604	807	14750	1384	3688	346
3/4-16	.6718	9926	1000	17015	1715	4254	429
7/8-9	.7368	11939	1320	20466	2262	5117	566
7/8-14	.7858	13580	1601	23278	2744	5820	686
1.0-8	.8446	15691	1988	26897	3408	6725	852
1.0-14	.8960	17654	2373	30261	4067	7566	1017
1-1/8-7	.9475	19743	2806	33842	4810	8461	1203
1-1/8-12	1.0210	22724	3511	39294	6018	9824	1505

11.5.1.3 Rejection procedure.

- (a) Beginning of set-up or shift. If any of the five studs tested show signs of failure, the conditions causing failure shall be rectified and the test repeated.
- (b) End of shift or set-up. If any of the five studs tested show signs of failure, a sampling plan shall be used to determine the extent of defective stud welding performed during the shift or set-up. The conditions causing failure shall be corrected and all defective studs welded during the shift or set-up shall be replaced.

11.5.2 Pressure containing applications. In addition to the testing required by 11.5.1, studs used in connection with openings in watertight, oil tight, gas or air tight, or pressure containing applications shall also be tested as follows:

- (a) Ten percent of the studs, but not less than two per opening, shall be torque tested in accordance with 11.5.1.2. The sample tested shall include the first and last studs welded for each opening. If any of the studs tested show signs of failure, all of the studs for the opening shall be tested. Studs showing signs of failure shall be removed and new studs welded and tested.

11.5.3 Nonpressure containing applications. For permanent nonpressure containing applications, the inspection requirements of 11.5.1 apply.

11.5.4 Temporary attachments. No testing is required for temporary attachment studs.

11.5.5 Repair to studs. Undercutting or lack of fusion up to 1/4 of the stud diameter may be ground and repair welded using shielded metal-arc or gas tungsten-arc welding processes. Undercutting or lack of fusion greater than 1/4 of the stud diameter indicates poor stud welding technique for which the cause shall be determined and corrected. Studs whose defects exceed 1/4 of the stud diameter shall be removed and the plate surface ground smooth. Each stud that has been repair welded shall be inspected in accordance with 11.5.1.2.

11.6 Hard surfacing valve parts. Hard surfacing alloys are overlaid on valve part areas subjected to abrasion, corrosion, impact, and seizure in service. Hard surfacing alloys may be applied by shielded metal arc, oxyacetylene, gas tungsten-arc, and plasma-arc welding processes. Use of the oxyacetylene process for S-8 materials shall be limited to low carbon or stabilized grades only. Applicable welding procedures shall list only these grades.

11.6.1 Preheating and heat treatment of carbon and alloy steel. Preheating shall be at least to the minimum preheat temperature specified in table IV. Upon completion of welding, the part shall be covered and allowed to cool slowly. Weldments may be post weld heat treated immediately upon completion of welding, without prior cooling. Postheat stress relieving of austenitic stainless steels shall be restricted to the stabilized and low carbon grades and shall require specific approval as specified in table VI. Stress relief for S-1, S-3 and S-4 materials is not required but may be performed for dimensional stability. For other alloy steels, stress relief shall be performed if required by table VI.

11.6.2 Inspection. Hard surfacing welds shall be visually examined and PT inspected in accordance with MIL-STD-271.

11.6.3 Acceptance. Hard surfacing welds shall be in accordance with visual acceptance requirements and criteria for PT tests specified in MIL-STD-2035.

11.7 Pipe and tube bending. Pipe and tube bending shall be in accordance with MIL-STD-1627.

12. CASTING INSPECTION

12.1 General. This section contains the minimum requirements for inspecting castings and repairing defects to the extent necessary to meet the applicable acceptance standard.

12.1.1 Castings purchased or manufactured by the contractor shall be in accordance with the specifications and standards specified herein, except NDT requirements shall be as specified herein. If no specifications or standards are referenced, drawings for castings which are subject to stress in service shall include the following information:

- (a) Chemical composition of material.
- (b) Required mechanical properties.
- (c) Melting process to be used.
- (d) Heat treatment, including aging or stabilizing treatments.
- (e) Cleaning methods to be used.
- (f) Pressure or proof test, if required.
- (g) RT, HT, or PT inspection requirements.
- (h) Identification markings.

12.2 Definitions.

12.2.1 Pressure containing. For purposes of section 12, pressure containing means a casting area which prevents contained fluid from escaping.

12.2.2 Sub-category. Sub-category designations (for example: A, A1, B, B1, C, C1, and so forth as shown in tables XIII, XIV, and XV for category 1, 2, and 3 castings) are assigned to simplify reference to the various application rules specifying which castings are to be inspected by which inspection rules.

TABLE XIII. Category 1, non-pressure containing castings in machinery or pressure vessels. 1/

Sub cat	Application rules	Stress due to	Stress level percent of yield	5/ 6/ Weight	NDT requirements			Sub cat
					RT	MT/PT2/	VT	
A3/	Castings which by failure of any one casting would prevent normal steering, diving, or propulsion and for which there is no standby capability.	Dynamic 4/ loads	A11	.	X	X	X	A1
		Hi impact shock grade A	>2/3	.	X	X	X	A2
			2/3 and <	.	-	X	X	A3
		Static loads	A11	.	-	X	X	A4
B	Castings which by failure of any one casting would reduce the capability of the ship to launch, land, or transfer aircraft between flight and hangar decks	Dynamic 4/ loads	A11	.	X	X	X	B1
		Hi impact shock grade A	>2/3	.	X	X	X	B2
			2/3 and <	.	-	X	X	B3
		Static loads	A11	.	-	X	X	B4
C	Castings for weapons handling systems, which by failure of any one casting would: (a) Result in dropping or damaging a weapon or (b) Result in reduction of weapons service to any space, launcher, or aircraft by 50 percent or more	Dynamic 4/ loads	A11	.	X	X	X	C1
		Hi impact shock grade A	>2/3	.	X	X	X	C2
			2/3 and <	.	-	X	X	C3
		Static loads	A11	.	-	X	X	C4

See footnotes at end of table.

TABLE XIII. Category 1, non-pressure containing castings in machinery or pressure vessels. 1/ - Continued

Sub cat	Application rules	Stress due to	Stress level - percent of yield	5/ 6/ Weight	NDT requirements			Sub cat
					RT	MT/PT2/	VT	
D	Other than A, B, and C	Dynamic 4/ 7/ loads or Hi impact shock grade A	> 2/3	>100 lbs	X	X	X	D1
				100 lbs and <	-	X	X	D2
			2/3 and <	A11	-	-	X	D3
		Static 8/ load	A11	A11	-	-	X	D4

- 1/ This table does not apply to castings used in components and accessories covered by sections 14, 15, and 16 in which the NDT requirements are specifically listed for the castings involved.
- 2/ MT or PT is required for ferrous castings. PT is not required for nonferrous castings.
- 3/ Ship propellers shall be subjected to VT with PT used only as an aid in locating discontinuities as specified in MIL-STD-2035 (RT not required).
- 4/ For purposes of clarification, castings stressed by dynamic loads are castings with areas which are designed for normal service dynamic loads of a degree and frequency that such loads are used in the strength equations which determine dimensions of the area (note: Hi impact shock is not a dynamic load for purposes of this rule).
- 5/ "Weight" is design weight (when design weight is not calculated, actual weight of finished part may be used).
- 6/ All weights of aluminum shall be subjected to RT and VT (PT not required).
- 7/ Includes static or dynamic loaded castings in weight handling equipment where the stress level under maximum test conditions exceeds 2/3 percent of the minimum specified yield strength of the material.
- 8/ Except for static loaded castings addressed by footnote 7.

TABLE XIV. Category 2. pressure containing castings - machinery
or pressure vessel castings. 1/

Application rules	Pressure 2/ (lb/in ²)	Size 3/ (inches)	NDT requirements 5/				Sub cat
			RT	MT/PT4/	Pressure 7/	VT	
Lethal or gasoline service	A11	A11	X	X	X	X	A
Oxygen or hydrogen service	A11	A11	X	X	X	X	B
Steam service	300 and >	2-1/2 and >	X	X	X	X	C
Gas (other than lethal, oxygen, or hydrogen), water or hydraulic service	1000 and > /	2-1/2 8/ and >	X	X	X	X	D
	300 to <1000 6/	2-1/2 and >	-	X	X	X	E
Special shipboard systems: (a) <u>Weapon service - all ships:</u> casting for weapons handling systems	A11	A11	X	X	X	X	F
(b) <u>Submarine service:</u> pressure castings associated with hull boundary and subject to submergence pressure	A11	A11	X	X	X	X	G
(c) <u>Aircraft carrier service:</u> castings, failure of which would reduce the capability to launch, land, or transfer aircraft between the flight and hangar decks	A11	2-1/2 and >	X	X	X	X	H
(d) <u>Combatant surface ships:</u> castings for normal steering systems	A11	2-1/2 and >	X	X	X	X	I
Castings not covered above	-	-	-	-	X	X	J

See footnotes at top of next page.

Footnotes to table XIV:

- 1/ Table XIV does not apply to castings used in components and accessories covered by sections 14, 15, and 16 in which the NDT requirements are specifically listed for the castings involved.
- 2/ "Pressure" is the design pressure of the system in which the casting is used.
- 3/ For machinery and pressure vessel castings, the size shown is the inside diameter (or an equivalent cross sectional area).
- 4/ MT or PT is required for ferrous castings. For nonferrous castings, PT inspection is required only on submergence pressure boundary surfaces where stresses due to normal working loads would exceed 2/3 of the yield strength of the casting material; otherwise PT inspection is not required.
- 5/ Where NDT requirements of the component specifications differ from those specified in this table, the former shall govern.
- 6/ Exception: Subcategory "D" NDT requirements shall apply to main feed water pump castings of design pressure of 550 lb/in² and greater.
- 7/ Refer to the applicable system or component specifications for pressure test requirements. Pressure test shall be conducted on uncoated castings.
- 8/ For hydraulic components with cylindrical datum features, this size is the largest diameter subject to normal operating pressure. For components with non-cylindrical datum features, the size shall be the largest dimension of the largest cross-sectional area subject to normal operating pressure.

TABLE XV. Category 3, pressure containing castings - piping system castings - valves, fittings, flanges, and auxiliary equipment. 1/

Application rules	Pressure 2/ (lb/in ²)	Nps 3/ size (inches)	NDT requirements 5/				Sub cat
			RT	MT/PT4/	Pressure 8/	VT	
Lethal or gasoline service	A11	A11	X	X	X	X	A
Oxygen or hydrogen service 9/	100 and >	1/2 and >	X	X	X	X	B

See footnotes at end of table.

TABLE XV. Category 3, pressure containing castings - piping system castings - valves, fittings, flanges and auxiliary equipment. 1/ - Continued

Application rules	Pressure 2/ (lb/in ²)	Nps 3/ size (inches)	NDT requirements 5/				Sub cat
			RT	HT/PT4/	Pressure 8/	VT	
Other than lethal or gasoline, oxygen or hydrogen and submarine seawater services 10/	> 3400	1 and >	X	X	X	X	C
	300 thru 3400	2-1/2 and >	X	X	X	X	D
	300 thru 3400	< 2-1/2	-	-	X	X	E
Submarine service 6/ (a) castings associated with pressure hull boundary and subject to submergence pressure	-	All	X	X	X	X	F
(b) castings in sea connected systems from the inboard flange of the backup valve outboard to the hull	-	All	X	X	X	X	G
(c) castings in sea connected systems inboard of the backup valve which are open to the sea below 200 feet submergence depth during any normal mode of operation	-	4 and > 7/	X	X	X	X	H
Castings not covered above	-	-	-	-	X	X	I

- 1/ Table XV does not apply to flange connections and fittings integral with components covered by sections 14, 15, and 16 and auxiliary equipment furnished with the basic equipment and specifically listed for the equipment involved.
- 2/ "Pressure" is the design pressure of the system in which the casting is used.
- 3/ For piping system castings, the size shown is nps size.
- 4/ HT or PT is required for ferrous castings. For nonferrous castings, PT inspection is required only on submergence pressure boundary surfaces, where stresses due to normal working loads would exceed 2/3 of the yield strength of the casting material.

- 5/ In event of conflict in NDT requirements between this table, the ship's specifications, the component specification or other documents, the more stringent NDT requirements shall be invoked.
- 6/ RT of cast valve discs and balls is required only where such discs or balls form a part of the hull boundary and failure could permit direct flooding inside ship, except RT is not required for centrifugally cast balls.
- 7/ Castings of sizes less than 4 inches shall be RT inspected where their failure would result in the loss of propulsion power due to lack of cooling water necessitated by the closing of the hull and back-up valves in the main seawater system for the purpose of isolating defective castings.
- 8/ Refer to the applicable system or component specification for pressure test requirements. Pressure tests shall be conducted on uncoated castings.
- 9/ RT and MT/PT requirements do not apply to castings in open ended oxygen or hydrogen vents or drains that are located between the last isolation valve and the open end.
- 10/ RT is not required for holding bulkhead isolation valves 2-1/2 inches NPS and larger with design pressure of 300 through 3400 psi of nonpropulsion systems unless required by other requirements of this military document.

12.3 Inspection details.

12.3.1 General. Tables XIII, XIV, and XV summarize the inspection requirements for cast nonpressure and pressure containing castings based on application, service conditions, size, and in some cases, stress. "X" indicates that the specific NDT test is required for the application and conditions described by the applicable pertinent horizontal data.

12.3.2 Visual examination. Each casting shall be visually examined for conformance with specified dimensions and surface conditions. Identification markings shall be checked to assure accuracy.

12.3.2.1 Inspection qualification. Visual examination shall be performed by personnel who have successfully passed the vision test in accordance with MIL-STD-271.

12.3.3 NDT. NDT shall be conducted in accordance with MIL-STD-271. Except as specified in 12.3.2 castings described for applications listed in tables XIII, XIV, and XV regardless of material shall be inspected by the NDT method indicated. Where MT/PT is indicated, materials which are magnetic at ambient temperatures shall be inspected by MT; materials which are non-magnetic shall be inspected by PT.

12.3.4 Radiographic standard shooting sketches. Shooting sketches prepared in accordance with MIL-STD-271 shall be provided to assist in interpretation of the applicable radiographics. Approval of the sketches is required.

12.3.5 Substitution of tests. When RT is specified and the geometry of the castings is such that inspection by radiography is not meaningful or cannot be performed in accordance with MIL-STD-271, MT or PT, as applicable, may be substituted when approved. PT may be substituted for MT when a casting surface location or condition is such that it is inaccessible for MT or may be injured or contaminated by the MT method. UT, in accordance with an approved written test procedure, may be substituted for RT when approved for the application.

12.4 Acceptance criteria.

12.4.1 Visual examination. Nonferrous casting surfaces shall be free from conditions specified in table XV.1 and other harmful or injurious defects. Ferrous castings shall meet the requirements of SP-55.

Table XV.1. Nonferrous casting VT acceptance criteria. 1/, 2/, 3/, 4/, 5/, 6/

A. Defect Type	B. For all casting categories except those of column C; indications exceeding the sizes and other criteria below are rejectable.	C. For table XIII casting categories D3 (except dynamically loaded castings) and D4, indications exceeding the sizes and other criteria below are rejectable. Does not apply to non-redundant weight handling castings or titanium castings which shall be per column B.
1. Cracks and Tears	None allowed.	None allowed.
2. Linear Indications (other than cracks and tears):		
a. All linear indications, except cold shuts (e.g., wrinkles, folds, oxide seams, etc.). <u>7/</u>	3/16" or 1/4T, whichever is less. All linear indications above 1/16" or 1/8T, whichever is less, shall be examined at 5X minimum magnification or explored by grinding to confirm the indications are not cracks, tears or cold shuts. All linear voids and inclusions shall not exceed non-linear criteria. <u>8/</u> , <u>9/</u>	1/4" or 1/3T, whichever is less. All linear indications above 1/16" or 1/8T, whichever is less, shall be examined at 5X minimum magnification or explored by grinding to confirm the indications are not cracks, tears or cold shuts. All linear voids and inclusions shall not exceed non-linear criteria. <u>8/</u> , <u>9/</u>
b. Cold shuts. <u>7/</u>	1/16" or 1/4T, whichever is less. <u>8/</u> , <u>9/</u>	1/8" or 1/3T, whichever is less. <u>8/</u> , <u>9/</u>
3. Non-Linear Indications:		
a. Voids such as gas holes, gas porosity and discrete shrinkage cavities.	3/32" or 1/4T, whichever is less, provided all internal surfaces of the indication are visible. <u>9/</u> , <u>10/</u>	3/16" or 1/3T, whichever is less, provided all internal surfaces of the indication are visible. <u>9/</u> , <u>10/</u>
b. Inclusions	3/32" or 1/4T, whichever is less. <u>9/</u> , <u>10/</u>	(1) For castings where T is less than 1.5" and all aluminum castings: 3/16" or 1/3T, whichever is less. <u>9/</u> , <u>10/</u> (2) For castings (excluding aluminum) where T is 1.5" or greater: 5/16" or 1/8T, whichever is less. <u>9/</u> , <u>10/</u>

Table XV.1. Nonferrous casting VT acceptance criteria. 1/, 2/, 3/, 4/, 5/, 6/ – Continued

A. Defect Type	B. For all casting categories except those of column C; indications exceeding the sizes and other criteria below are rejectable.	C. For table XIII casting categories D3 (except dynamically loaded castings) and D4, indications exceeding the sizes and other criteria below are rejectable. Does not apply to non-redundant weight handling castings or titanium castings which shall be per column B.
4. Tightly adherent sand, scale and other foreign material.	None allowed.	None allowed.
5. Raised metal surfaces having a jagged or irregular surface not addressed by drawing.	Surfaces shall be smoothly blended into surrounding surfaces.	Surfaces shall be smoothly blended into surrounding surfaces.

- 1/ Criteria apply to cast, rough ground or machined surfaces, except for critical machined surfaces. Critical machined surfaces are O-ring surfaces, gasket surfaces and other sealing surfaces, seating surfaces, threaded surfaces and surfaces within 1/2" from intended welds. Critical machined surfaces shall be free of all defects, including those otherwise permitted by Note 4/, unless the defect is within the other limits of this table and is approved by the Design Yard, Planning Yard or Authorized Representative, as applicable.
- 2/ A linear indication is an indication in which the length is equal to or greater than three times the width. A non-linear indication is an indication whose length is less than three times the width.
- 3/ T is the design casting thickness at the indication location. Indications, and excavations of indications not repair welded, shall not reduce casting thickness below the design thickness. Ground areas shall be smoothly blended.
- 4/ Linear indications with length less than or equal to 1/16" or 1/8T, whichever is less, and non-linear indications whose major dimension is less than or equal to 1/16" or 1/8T, whichever is less, do not require classification and are acceptable if acceptably separated (see Notes 8/ and 10/). Indications less than 0.015", regardless of proximity, do not require classification and are acceptable.
- 5/ Not applicable to high pressure die castings (e.g., ASTM B85). Criteria for high pressure die castings shall be proposed by the casting designer for approval by NAVSEA.
- 6/ Indications that are PT inspected and meet the acceptance criteria of table XVI are acceptable.
- 7/ A cold shut is an imperfect junction between two flows of metal in a mold caused by the surface of the streams of metal chilling too rapidly, or in effect, being chilled to the extent that fusion does not occur. This discontinuity may have the appearance of a crack or seam with smooth or rounded edges.
- 8/ Longitudinally aligned linear indications shall be separated by 4D where D is the length of the longer indication. Non-aligned linear indications shall be separated by 2D. There shall be no more than 10 linear indications in any 6" x 6" area. Smaller areas shall be prorated.
- 9/ If minimum indication separation is less than required, then where the total indication lengths (i.e., including separation between indications) are less than the maximum permissible indication size, the indications shall be acceptable.
- 10/ Random individual non-linear indications shall be separated by 2D where D is the maximum dimension of the larger indication. There shall be no more than 4 non-linear indications in any 2" x 2" area. Smaller areas shall be prorated.

S9074-AR-GIB-010A/278

12.4.2 MT, PT, and RT. Acceptance criteria for MT, PT, and RT shall be as specified in tables XVI, XVII, XVIII, XIX, and XX.

TABLE XVI. Acceptance criteria for MT and PT. 1/

Cast material	Finished metal thickness	MT	PT
	(Inches)	MIL-STD-2035	
<u>FERROUS CASTINGS</u>			
Corrosion-resistant steel	Less than 1	Class 1	Class 1
Carbon steel	1 to 3	Class 2	Class 2
Alloy steels	over 3	Class 3	Class 3
<u>NONFERROUS CASTINGS</u>			
Nickel base alloys			
Copper-nickel			
Aluminum-bronze	1 and less	---	Class 2
Nickel-aluminum-bronze	over 1	---	Class 3
Manganese-bronze			
Tin-bronze	1/2 and less	---	Class 2
	over 1/2	---	Class 3
Aluminum	---	---	Class 2
Titanium-titanium alloys	Less than 1	---	Class 1
	1 to 3	---	Class 2
	over 3	---	Class 3
<p>Note:</p> <p>1/ It is characteristic of some castings to be subject to superficial surface craze cracking. MT or PT indications of such craze cracking shall not be prejudicial when they do not exceed 5/16 inch in length. Indications beyond this length shall require removal, except that such indications may be approved subject to technical evaluation for acceptability dependent on intended application service conditions.</p>			

TABLE XVII. RT acceptance criteria for aluminum castings.

Cast material: Aluminum															
Casting category: 1, 2, 3															
Metal thickness (plan dimensions for finished parts) inches	Hot cracks, cold cracks, cold shuts, misruns	Radiography 1/													
		Type of discontinuity													
		Gas holes		Gas porosity				Shrinkage				Foreign material			
				Round		Elongated		Cavity		Sponge		Less dense		More dense	
		Plate	Grade	Plate	Grade	Plate	Grade	Plate	Grade	Plate	Grade	Plate	Grade	Plate	Grade
Inches		Inches		Inches		Inches		Inches		Inches		Inches			
1/2 and less	None	1.1-1/4	3	1.21-1/4	4	1.22-1/4	4	2.1-1/4	3	2.2-1/4	4	3.11-1/4	3	3.12-1/4	3
Over 1/2 thru 1-1/4	None	1.1-3/4	5	1.21-3/4	5	1.22-3/4	5	2.1-1/4	4	2.2-3/4	4	3.11-3/4	4	3.12-3/4	4
Over 1-1/4 thru 2	None	1.1-3/4	6	1.21-3/4	6	1.22-3/4	6	2.1-1/4	5	2.2-3/4	5	3.11-3/4	5	3.12-3/4	5
Over 2 thru 3	None	1.1-3/4	7	1.21-3/4	7	1.22-3/4	7	2.2-1/4	7	2.2-3/4	6	3.11-3/4	6	3.12-3/4	6
Over 3	None	1.1-3/4	8	1.21-3/4	8	1.22-3/4	8	2.1-1/4	8	2.2-3/4	8	3.11-3/4	7	3.12-3/4	7

See footnotes at top of next page.

Original 113

S9074-AR-GIB-010/278

Footnotes to table XVII:

- 1/ ASTM E 155, reference radiographs (films) shall be applied as specified. Reference films listed provide a basis for acceptability by comparison with production radiographs. Discontinuities shown in the reference film are acceptable in any unit area as defined below and may be accepted when discontinuities in production radiographs are concentrated in an area the size of the reference film (2 by 2 inches) provided the balance of the unit area is clear. The unit area shall be a square, 4 inches on each side. Areas less than a unit area shall be judged proportionately to the unit area.

TABLE XVIII. RT acceptance criteria for steel (carbon, alloy, and corrosion resistant), titanium, and titanium alloy castings.

Thickness (inches)	Criticality level <u>1/</u>	ASTM standard <u>2/</u>	Maximum severity level				
			Shrinkage	Porosity	Inclusion	Hot tear, crack	Insert, chaplet
Less than 1	1	E 446	CA 2 CB 2 CC 2 CD 2	A 2	B 2	None	None
	2	E 446	CA 3 CB 3 CC 3 CD 3	A 3	B 3	None	<u>3/</u> EA 2
	3	E 446	CA 4 CB 4 CC 4 CD 4	A 4	B 4	None	<u>3/</u> EA 2
1 to 2	1	E 446	CA 3 CB 3 CC 3 CD 3	A 3	B 3	None	None
	2	E 446	CA 4 CB 4 CC 4 CD 4	A 4	B 4	None	<u>3/</u> EA 3
	3	E 446	CA 5 CB 5 CC 5 CD 5	A 5	B 5	None	<u>3/</u> EA 3

See footnotes at end of table.

TABLE XVIII. RT acceptance criteria for steel (carbon, alloy and corrosion resistant), titanium, and titanium alloy castings. - Continued

Thickness (inches)	Criticality level <u>1/</u>	ASTM standard <u>2/</u>	Maximum severity level				
			Shrinkage	Porosity	Inclusion	Hot tear, crack	Insert, chaplet
Over 2 to 4-1/2	1	E 186	CA 3 CB 3 CC 3	A 3	B 3	None	None
	2	E 186	CA 4 CB 4 CC 4	A 4	B 4	None	EA 3, EB 3
	3	E 186	CA 5 CB 5 CC 5	A 5	B 5	None	EA 4, EB 4
Over 4-1/2	1	E 280	CA 2 CB 2 CC 2	A 3	B 3	None	None
	2	E 280	CA 3 CB 3 CC 3	A 4	B 4	None	EA 3, EB 3
	3	E 280	CA 5 CB 5 CC 5	A 5	B 5	None	EA 4, EB 4

- 1/ Criticality level 1: Areas requiring 75 percent minimum RT coverage (see 12.5.3).
 Criticality level 2: Areas requiring 50 percent minimum RT coverage (see 12.5.3).
 Criticality level 3: Areas not requiring RT but are inadvertently radiographed or radiographed for information purposes.
- 2/ Evaluation or radiographs for acceptance shall be in accordance with the applicable ASTM standard.
- 3/ ASTM E 186 shall be used for evaluation purposes.

TABLE XIX. RT acceptance criteria for nonferrous castings. 1/
 (a) Nickel base alloys. (d) Nickel-aluminum-bronze.
 (b) Copper-nickel. (e) Manganese-bronze.
 (c) Aluminum-bronze.

Criticality level			Severity level										ASTM E 186 (except as noted)	
			ASTM E 272											
			Shrinkage			Dross		Porosity		Inclusions				
Thick-ness	Level	Level definitions	Type	Reference radiograph	Source	Reference radiograph	Source	Reference radiograph	Source	Reference radiograph	Source	ASTM standard	Reference radiograph	
1 inch and less	1	Areas requiring 75 percent and > RT coverage (see 12.5.3)	Feathery Spongy Linear	Cd 2 Cd 2 Ca 2	X-ray Gamma Gamma	Bb 1	X-ray	A3	X-ray	Ba 3	X-ray	None acceptable		
	2	Areas requiring 50 percent min. RT coverage (see 12.5.3)	Feathery Spongy Linear	Cd 3 Cd 3 Ca 3	X-ray Gamma Gamma	Bb 2	X-ray	A4	X-ray	Ba 4	X-ray	E 186	EA 4	
	3	Areas not requiring RT but inadvertently radiographed or radiographed for information purposes	Feathery Spongy Linear	Cd 4 Cd 4 Ca 4	X-ray Gamma Gamma	Bb 3	X-ray	A5	X-ray	Ba 5	X-ray	E 186	EA 5	
Over 1 inch	1	Same as level 1 as defined above	Feathery Spongy Linear	Cd 3 Cd 3 Ca 3	X-ray Gamma Gamma	Bb 2	Gamma	A3	Gamma	Ba 3	Gamma	None acceptable		
	2	Same as level 2 as defined above	Feathery Spongy Linear	Cd 4 Cd 4 Ca 4	X-ray Gamma Gamma	Bb 3	Gamma	A4	Gamma	Ba 4	Gamma	E 186	EA 4	
	3	Same as level 3 as defined above	Feathery Spongy Linear	Cd 5 Cd 5 Ca 5	X-ray Gamma Gamma	Bb 4	Gamma	A5	Gamma	Ba 5	Gamma	E 186	EA 5	

See footnotes at top of next page.

Original 116

S9074-AR-GIB-010/278

Footnotes to table XIX:

1/ ASTM E 272 and E 186 reference radiographs (films) shall be applied as specified. Reference films in ASTM E 272 are identified by two thickness ranges: (a) up to 2 inches and (b) 2 to 6 inches. Films are shown for the various discontinuity types in both thickness ranges. Three types of shrinkage are shown, designated (a) Feathery, (b) Spongy and (c) Linear. Only feathery type is shown in the up to 2-inch thickness range, and spongy and linear types are shown in the 2-inch to 6-inch thickness range. Films from both thickness ranges have been used without regard to applicable thickness specified herein in order to provide the best coverage and gradation of discontinuities. Since film identification designations are duplicated in the two thickness ranges, they are further identified in the table by stating the source. Where "X-Ray" appears under source in the table, this indicates that the "Low Voltage X-Ray Film" is applicable. Where "gamma" appears under source in the table, this indicates that the "2 MEV X-Ray or Cobalt-60 Gamma Ray Film" is applicable. Reference films specified shall be used for all production radiography sources.

TABLE XX. RT acceptance criteria for tin-bronze castings.

Criticality level			Severity level					
			ASTM E 310				ASTM E 186 (except as noted)	
Thickness	Level	Level definitions	Shrinkage		Porosity	Inclusions	Chaplets	
			Type	Reference radiograph	Reference radiograph	Reference radiograph	ASTM standard	Reference radiograph
1/2 inch and less	1	Areas requiring 75 percent and > RT coverage (see 12.5.3)	Linear	Ca 2	A2	B1	None acceptable	
			Feathery or Spongy	Cd 1				
	2	Areas requiring 50 percent min. RT coverage (see 12.5.3)	Linear	Ca 3	A3	2/ B3	None acceptable	
			Feathery or Spongy	Cd 2				
	3	Areas not requiring RT but inadvertently radiographed or radiographed for information purposes	Linear	Ca 4	A4	B2, 2/ B4	E 186	EA 3
			Feathery or Spongy	Cd 3				
Over 1/2 inch	1	Same as level 1 as defined above.	Linear	Ca 3	A3	2/ B3	None acceptable	
			Feathery or Spongy	Cd 3				
	2	Same as level 2 as defined above	Linear	Ca 4	A4	B2, 2/ B4	E 186	EA 3
			Feathery or Spongy	Cd 3				
	3	Same as level 3 as defined above	Linear	Ca 5	A5	B5	E186	EA 4
			Feathery or Spongy	Cd 4				

See footnotes at top of next page.

- 1/ ASTM E 310 and E 186 reference radiographs (films) shall be applied as specified. The specified films shall be used for all production radiography sources.
- 2/ For the inclusion films, the discontinuities of film B2 are considered to be more severe than those of B3. Those of B2 and B4 are considered to be approximately equal, with those of B4 being fewer in number but larger in size.

12.4.2.1 RT evaluations. Production radiographs shall be evaluated for acceptance by comparing them with the applicable ASTM reference radiographs listed in tables XVII, XVIII, XIX, and XX.

12.4.2.2 Investment castings. Investment castings shall meet the number 5 acceptance level of ASTM E 192 except that filamentary type shrinkages contained therein are not permitted. For double-wall radiography a reference radiograph with a wall thickness compatible with the thickness of both walls of the casting being radiographed shall be used; however, the number 4 acceptance level shall then be used for evaluation purposes.

12.4.3 Pressure test. Pressure test acceptance criteria shall be in accordance with the applicable material, system, or equipment specification.

12.4.4 UT. UT acceptance criteria shall be approved on a case basis.

12.5 Extent of NDT.

12.5.1 VT. VT shall be conducted on 100 percent of all accessible casting surfaces or areas which comprise the finished part. Gates, risers, test coupons, temporary test flanges, or similar extensions used as part of foundry procedure are excluded.

12.5.2 Pressure tests. Pressure tests shall be applied to all pressure containing areas.

12.5.3 Extent of radiography. Castings shall receive complete coverage, when required, in accordance with tables XIII, XIV, and XV. Insofar as casting configurations and thickness variations prevent attainment of the required film density in some locations, and for the purpose of defining coverage required, a casting is considered to contain the following areas:

- (a) 75 percent minimum radiographic coverage areas. Areas include pressure containing areas, areas designed for dynamic loads in accordance with footnote 4, table XIII and areas stressed to 2/3 or more of the yield strength under high-impact shock.
- (b) 50 percent minimum radiographic coverage areas. Remaining areas in the casting.

The 75 or 50 percent minimum coverage is defined as casting areas in the film which are within the specified density limits and are interpretable. It is not the intent that only 75 or 50 percent of casting be radiographed and that any specific area be excluded. Noncritical areas need not be radiographed when approved.

12.5.4 Extent of MT or PT inspection for ferrous castings. Ferrous castings for which radiography is required in accordance with tables XIII, XIV, or XV shall receive in addition to radiography, 100 percent MT or PT inspection of all accessible areas. Ferrous castings for which MT or PT inspection is required in accordance with tables XIII, XIV, or XV and radiography is not specified shall receive 100 percent MT or PT inspection of all accessible surface areas. Static loaded ferrous castings shall receive 100 percent MT or PT inspection of all accessible surfaces which are subject to static loading.

12.5.5 Extent of PT for nonferrous castings. Except as required by footnote 3 to table XIII and footnote 4 to tables XIV and XV, nonferrous castings do not require PT inspection.

12.5.6 Records for NDT of castings. Records of casting inspection by VT and NDT methods shall be as follows:

- (a) Casting identification, including heat number and where applicable, heat treatment lot number, drawing number and serial number.
- (b) Material identification by specification number and class or alloy.
- (c) Inspection methods and results.
- (d) For submarines, extent of inspection and traceability.

Inspection records for castings shall include casting repair records as specified in 13.2.10.

12.6 NDT responsibilities.

12.6.1 Designer responsibility. Where 100 percent inspection is not required, the casting designer shall implement the requirements of 12.5.3 and 12.5.4 by identifying areas requiring NDT on engineering drawings by appropriate assignment of symbols conforming to AWS A2.4.

12.6.2 Contractor responsibility. The foundry or activity performing the radiography shall prepare the radiographic shooting sketch in accordance with MIL-STD-271 based on requirements established by the designer (see 12.1.1). Prior to preparation, the design requirements for radiography shall be reviewed to ensure feasibility from the fabricator point of view. When disagreements arise between the designer and foundryman concerning areas for which radiography is required, but considered impractical by the foundryman, a meeting of both parties shall be arranged to resolve any controversial issues. Drawings shall be modified to reflect the decisions mutually reached by the designer and foundryman. Since a variety of

processes are permitted under MIL-STD-271, the shooting sketches will necessarily depend not only on the coverage requirements but the equipment and procedures of the particular radiographic facility.

12.6.3 Approvals.

12.6.3.1 Engineering drawings. Casting drawings marked for RT coverage as required by 12.6.1 shall be forwarded to the acquisition activity for acceptance. Copy of transmittal letter shall be forwarded to the DCASMA.

12.7 Weldability tests. When required by the applicable cast material specification, weldability tests shall be performed to demonstrate that a particular heat of metal is of a composition that is readily weldable.

12.8 Sample castings. Except for castings covered in sections 14, 15 and 16, prior to production of a number of similar castings for which foundry methods or techniques have not been established, one or more sample castings shall be produced and subjected to NDT sampling agreed to by the designer and foundry. The results of this NDT shall be reviewed by both designer and foundry prior to production of the remaining castings. Significant changes to casting procedures, thereafter, shall be subject to a similar sample casting review for the area affected by the change.

13. REPAIR OF CASTINGS

13.1 Impregnation. Only castings of copper-base alloys or aluminum-base alloys shall be considered for approval to impregnate. Impregnation of castings will be permitted to seal off minor leakage due to micro-porosity or other casting defects only after NAVSEA approval and when the defective castings are shown by radiography to be structurally sound. The suitability of aluminum base alloy casting for impregnation shall be based on review of the individual radiographs. Copper-base alloy castings which conform to the applicable classification of radiographic standards are considered satisfactory for impregnation. Copper-nickel castings shall not be impregnated. Castings of any alloy for oxygen service shall not be impregnated. Welding shall not be permitted on castings which have been impregnated.

13.1.1 Impregnation authority. Authority to impregnate castings shall be obtained from NAVSEA. Requests for authority to impregnate shall be accompanied by radiographs of the defective areas of the particular casting or representative casting in the case of a large lot, together with complete information as to the condition of the castings including marked drawings where applicable, the percentage of castings of each type requiring impregnation, the service for which intended, the name of the foundry or contractor, and the contract or order number. Approval to impregnate is solely at NAVSEA discretion. In addition to the above requirements approval or disapproval depends upon other considerations such as temperature, pressure, service application (including the need/means for in-service repair) and a comparison of service exposure duration and severity to the conditions in MIL-I-17563 qualification tests.

13.1.2 Impregnation procedure. The impregnation of castings, when approved by NAVSEA, shall be performed in accordance with MIL-STD-276. Each casting which has been impregnated shall be stamped "IMP" on the stamping pad or in a conspicuous place that will not impair the strength or serviceability of the casting.

13.2 Repair welding.

13.2.1 General. This section contains requirements for repair of weldable castings. In the event of a conflict between requirements specified herein and those contained in casting material specifications, the requirements specified herein shall govern.

13.2.2 Minor repairs. Minor repairs are those repairs which do not exceed the following limits:

- (a) Maximum depth does not exceed 20 percent of the casting thickness or 1-inch depth, whichever is less, and individual repair areas do not involve more than 4 percent of the casting surface.
- (b) Weld build-up for correction of casting dimensions or machining discrepancies not exceeding 10 percent of the total area of the castings may be made at the discretion of the contractor or foundry when the weld build-up is within the following limitations:

- (1) 3/16-inch maximum build-up for wall thicknesses 1 inch and under; or
- (2) 20 percent of wall thickness maximum build-up for wall thicknesses over 1 inch but not to exceed 3/8 inch.

NOTE: These thickness limitations apply to the finished condition.

13.2.3 Nominal repairs. Nominal repairs are repair welds in excess of those outlined in 13.2.2 but which do not exceed 1/2 the casting thickness.

13.2.4 Special repairs. Special repairs are those repairs for which excavations of defects are more extensive than those classified as nominal repairs or those that extend through the thickness of the casting, or for which the use of cast inserts may be desired.

13.2.5 Authority for repair of castings. Authority to perform repair on castings by welding shall be as follows:

- (a) Minor repairs may be made at the discretion of the contractor or foundry.
- (b) Nominal repairs of castings may be accomplished without obtaining approval provided that in addition to the records required (see 13.2.10), the manufacturer shall record the casting identification number, welding procedure number or title, welder identification, and name of the authorized representative.
- (c) Special repairs require advance approval of the authorized representative.

The authorized representative shall be notified that repair welding has commenced. The Government representative reserves the right to reject castings where there is evidence that the provisions of this section are violated.

NOTE: For nickel-aluminum-bronze castings, weld repairs (including post weld heat treatment) shall be in accordance with MIL-B-24480 (see 6.4.5).

13.2.5.1 Repair procedures and report. Casting repairs shall be completed in accordance with 13.2.5. Upon completion of nominal and special repairs copies of records required by 13.2.10 shall be made available upon request.

13.2.6 Heat treated weld repairs. For ferrous castings which are to be heat treated at temperatures above the critical transformation temperature, weld repair using weld metal which is responsive to heat treatment may be accomplished prior to such heat treatment provided castings are given a preliminary anneal or softening treatment to avoid welding in the as-cast condition, and the following operations may be performed in this condition:

- (a) Radiography of the castings.
- (b) Weld repair of the casting.
- (c) Re-radiography of weld repairs.

Responsiveness of the filler metal to the specific heat treatment employed shall be established by procedure qualification test. Heat treatment as appropriate shall be performed after the foregoing operations. Required MT inspection shall be performed after such heat treatment. Should any weld repairs develop by reason of the MT inspection, repair shall be accomplished and re-radiography of the repair shall be performed if required. Post weld treatment shall then be either re-heat treatment or stress relief treatment as appropriate. MT inspection shall be performed following the final thermal treatment operation. Stress relief of repair welded castings shall be in accordance with table VI and section 8. In this regard where the term weldment is used, it shall be construed to include repair welded castings.

13.2.7 Stress relief of weld repairs. When stress relieving of repair welded castings is performed in furnaces having recording pyrometric controls, the furnaces shall be calibrated to verify that the temperature variation within the furnace does not exceed 75°F. Calibration of the furnace shall be maintained by a recheck at intervals of no less than 6 months or after any changes or repairs to the furnace that might affect its temperature distribution. Holding temperatures, time and cooling rates shall be as established by the approved welding or heat treatment procedure.

13.2.7.1 Alternate temperature measuring methods for furnace and local stress relief. Alternate temperature measuring methods specified in section 8 are applicable.

13.2.8 Inspection of repair welds.

13.2.8.1 Exploration and repair of cracks. Visual evidence of cracks shall be explored at 5X magnification or by PT inspection and the cracks shall be removed and repaired by welding (see 13.2.8.2) or faired in or radiused providing wall thickness is not reduced below the specified allowable thickness. PT inspection shall be limited to the immediate area of the defect when exploring defects in welds in S-51, S-52, and S-53 materials that will subsequently be repaired by welding. Surrounding areas which may later be overwelded shall be masked away from penetrant or developer. When a defect has been removed, the PT inspected area shall be burred with a carbide burr before welding any further.

13.2.8.2 Surface passes. Completed repair welds, including the adjacent casting surface for a distance of 1/2 inch from the weld edge, shall be inspected by the MT or PT methods, as may be applicable except as noted in 13.2.8.2.1.

13.2.8.2.1 For non-ferrous castings where PT inspection is not required by footnote 2 to table XIII and footnote 4 to tables XIV and XV, the adjacent casting surface (1/2 inch from weld edges) shall be visually examined. For the heat affected zone (3/16 inch from weld edges), the visual examination shall be at 5X minimum magnification. Where the surfaces within 1 inch of weld edges are PT inspected inadvertently during the inspection of the weld deposit, suspect indications within the 1-inch area shall be noted; then the developer and penetrant shall be removed and suspect areas visually examined at 5X minimum magnification. Linear indications greater than 1/16 inch shall be cause for rejection by the visual examination specified herein.

13.2.8.3 Radiography of completed repair. Repair welds in casting areas originally requiring radiography shall be radiographed except in the following case:

Radiography is not required for repair welds of defects not detected by radiography or pressure test if they conform to the criteria of 13.2.2 for minor repairs and are satisfactorily PT or MT inspected as applicable.

13.2.8.4 For repair welds in castings that require radiography which are 3/8 inch and greater in thickness and are made with MIL-120S or MIL-12018 filler metals, also perform the MT inspection required by 10.3.12.

13.2.9 Acceptance standards for repair welds. Acceptance criteria for repair welds shall be as follows:

<u>Inspection Method</u>	<u>Acceptance Standard</u>
RT	(see note 1)
MT	MIL-STD-2035 (see note 2)
PT	MIL-STD-2035 (see note 2)

NOTES:

1. Repair of casting radiographic indications is required only to the extent of bringing such indications within the applicable casting acceptance standard. When radiographs are made after repair excavations, and prior to weld repair to determine the extent of any remaining discontinuities, the acceptance standard for the design thickness of the casting in the excavated area shall apply. UT inspection employed in accordance with an approved procedure may be used for such thickness determination. For post weld repair radiography, discontinuities occurring in the weld metal shall be judged for acceptance to the applicable reference radiograph for casting defects. If the combination of weld defects and casting defects does not exceed the discontinuities allowed in the applicable referenced radiograph for castings, the area shall be accepted. Cracks, lack of fusion, and incomplete penetration in the area of weld repair shall be rejected. Slag and porosity shall be judged as sand inclusions and gas, respectively.

2. MT and PT of repair welds shall be in accordance with the following:

<u>Repair welds in</u>	<u>Finished material thickness (inches)</u>	<u>Acceptance criteria MIL-STD-2035</u>	
		<u>MT</u>	<u>PT</u>
<u>Ferrous castings</u>			
Corrosion-resistant steel	Less than 1 1 to 3 3 and over	Class 1	Class 1
Carbon steel 1 to 3		Class 2	Class 2
Alloy steels 3 and over		Class 3	Class 3
<u>Nonferrous castings</u>			
Nickel-base alloys	1 and less Over 1	-----	Class 2
Copper-nickel		-----	Class 3
Aluminum-bronze		-----	-----
Nickel-aluminum-bronze		-----	-----
Manganese-bronze		-----	-----
Tin-bronze	-----	-----	
<u>Aluminum castings</u>			
1/ <u>Special-alloy casting (S-8)</u>	All	-----	Class 2
CN-7M	All	-----	Class 3
CN-7MS			
<u>Titanium and Titanium Alloy Castings</u>			
	less than 1	-----	Class 1
	1 to 3	-----	Class 2
	over 3	-----	Class 3

- 1/ It is characteristic of these castings to be subject to superficial surface craze cracking. MT or PT indications of such craze cracking shall not be prejudicial when they do not exceed 5/16 inch in length. Indications beyond this length shall require removal, except that such indications may be approved subject to technical evaluation for acceptability dependent on intended application service conditions.

13.2.10 Records. Records of weld repairs shall be maintained and shall include the following (except as modified in sections 14, 15 and 16):

- A sketch showing the size (length, width, and depth) and location of all nominal and special repairs.
- Record of post weld heat treatment (when applicable).
- Record of weld repair inspection results.

- (d) Record of material weldability test when required by the applicable material specification.
- (e) Records shall be retained as required by 13.2.10.1.

13.2.10.1 Maintenance of records. Unless otherwise specified, required records shall be maintained by the activity and be available to the NAVSEA representative throughout the life of the contract and for 3 years after delivery. At the expiration of the record retention period, NAVSEA or its authorized representatives shall be given a written notification. Disposal of records shall be as agreed upon by NAVSEA and the contractor.

13.2.11 Repair welding on existing shipboard castings. Repair welds made on existing shipboard castings shall be inspected by the MT or PT method, as specified in 13.2.8.2. RT shall also be performed when repair welding is located in an area for which radiography was specified for the casting in new condition, except radiography is not required where the following provisions are met:

- (a) Weld overlay is used to restore surface material lost through corrosion, erosion, and wear.
- (b) Depth of area prepared for welding does not exceed the allowable depth of a nominal repair (see 13.2.3).
- (c) Finished weld thickness is 3/8 inch or less.

Where the provisions of (a), (b), and (c) apply to castings of S-1 material, post weld stress relief is not required. For repair welding on nickel-aluminum-bronze see the special note to 13.2.5.

14. NDT REQUIREMENTS FOR TURBINE PARTS

14.1 General. This section contains the minimum inspection requirements for welds, weldments, and castings used in auxiliary and main propulsion turbine components and accessories.

14.2 Inspection requirements.

14.2.1 Turbine components or parts (fabrication, welds, and castings) shall be inspected in accordance with table XXI.

TABLE XXI. NDT inspection of turbine parts. 1/

Part or service	MT/PT	RT	HT	UT	VT
Bearing pedestals and caps:					
(a) Weld joints	X-3	-	-	-	X
(b) Castings	X-3	-	-	-	X
<u>Ahead casings and steam chests: 2/</u>					
(a) Below 300 lb/in ²	X-3	-	X	-	X
(b) 300 to 900 lb/in ²	X-2	3/X-1	X	-	X
(c) Above 900 lb/in ²	X-1	3/X-1	X	-	X
<u>Astern castings and nozzle chamber: 2/</u>					
(a) Below 300 lb/in ²	X-3	-	X	-	X
(b) 300 to 900 lb/in ²	X-2	-	X	-	X
(c) Above 900 lb/in ²	X-1	-	X	-	X
<u>Inner shells and nozzles chambers 2/</u>	X-2	-	-	-	X
<u>Diaphragms</u>	X-3	-	-	-	X
<u>Control mechanism and operating gear</u>	X-3	-	-	-	X
<u>Supports, flexible</u>	X-2	-	-	-	X
<u>Support girders for turbines (fabrications, welds, and castings)</u>	X-2	-	-	-	X
<u>Control valves</u>					
(a) Seating surface of valve and seat weld overlay/inlay	X-1	-	-	-	X
<u>Expansion joints (cross-over)</u>	X-3	-	X	-	X
<u>Gland seal regulator body (hydraulic type)</u>	X-3	-	X	-	X

See footnotes at end of table.

Original 127

TABLE XXI. NDT inspection of turbine parts. 1/ - Continued

Part or service	MT/PT	RT	HT	UT	VT
Piping butt welds: (steam)					
(a) Below 300 lb/in ²	X-2	-	X	-	X
(b) 300 lb/in ² and above. <2-1/2 inches	X-1	-	X	-	X
(c) 300 lb/in ² and above. (2-1/2 inches and above) 2/	X-1	X-1	X	-	X
Piping fillet welds (steam) 300 lb/in ² and above	X-1	-	X	-	X
Piping and piping welds (oil)	-	-	X	-	X
Weld overlay/inlay (for erosion resistance)	-	-	-	-	X
Valve bodies (trip throttle, astern, guard, strainer, maneuvering, and non-return) 2/					
(a) Below 300 lb/in ²	X-2	-	X	-	X
(b) 300 lb/in ² and above	X-1	3/X-1	X	-	X
Valve seat seal weld	X-2	-	-	-	X

1/ Inspections required do not eliminate requirements of applicable material specifications.

X- Indicates test required

X- Followed by number indicates acceptance class or level

2/ Records as specified in 13.2.10 are required.

3/ Applicable to castings with an inside diameter 2-1/2 inches or greater (or an equivalent cross sectional area).

14.2.2 Radiography of castings and steam chests. Radiography of castings and steam chests shall be as follows:

(a) External pressure boundary walls above valve seats (nozzle control and by-pass).

(b) Steam inlet.

(c) Steam chest flange and cover (castings only).

- (d) Front wall and first stage shell area (horizontal flange excluded) where inlet gauge pressure to chest is 900 lb/in² or greater.
- (e) All fabrication welds in the above areas.

14.3 Performing NDT inspection.

14.3.1 NDT inspection shall be performed in accordance with MIL-STD-271.

14.3.2 Radiographic standard shooting sketches. Shooting sketches in accordance with MIL-STD-271 shall be provided to assist in interpretation of the applicable radiographs; however, approval of the sketches is not required.

14.4 Acceptance standards for NDT inspection.

14.4.1 Radiography. Radiography of welded joints and repair welds in castings shall be compared and shall be in accordance with class 1 of MIL-STD-2035. Castings radiographs shall conform to table XXI.

14.4.2 MT and PT inspection of welds. Inspection for surface discontinuities in welds and adjacent areas shall be performed by MT or PT method. In general, the MT method shall be used on ferrous materials and the PT method on nonferrous material and austenitic corrosion resistant steels. Acceptance criteria for welds shall be in accordance with MIL-STD-2035.

14.4.3 MT and PT inspection of castings. There shall be 100 percent MT or PT inspection of all accessible areas for items shown in table XXI. Acceptance standards shall be in accordance with MIL-STD-2035, except that footnote 1 of tables VI and X, therein, does not apply.

14.5 UT inspection.

14.5.1 UT inspection in accordance with an approved written test procedure and acceptance standards may be substituted for radiography when approved for the application.

14.6 Additional inspection for ferritic materials.

14.6.1 Ferritic castings and fabrication welds thereto which are subject to NDT prior to stress relief, as permitted by MIL-STD-271, shall be subjected to MT after stress relief. Acceptance standards shall be as required for the parts or welds involved.

15. NDT INSPECTION REQUIREMENTS FOR PROPULSION REDUCTION GEARS AND STEAM TURBINE DRIVEN AUXILIARY GEARS

15.1 General. This section contains the minimum inspection requirements for welds and castings used in the fabrication of propulsion reduction gears.

15.2 Inspection requirements.

15.2.1 Propulsion reduction gear components or parts shall be inspected in accordance with table XXII.

TABLE XXII. NDT inspection of propulsion reduction gear parts (including steam turbine driven auxiliary gears).

Part or service	MT/PT	HT	UT	LT	VT	Reference notes
Main element forgings for: Pinions, gears, gear rims, shafts, annulus, carrier	X-VA	-	X-VA	-	-	<u>1/ 2/</u>
Teeth of main elements	X-VA	-	-	-	-	<u>2/ 3/</u>
Piping welds						
(a) Small sections of low pressure such as lube oil supply, including welds joining nipple to casing	X-VA	-	-	-	X	-
(b) All other low pressure lube oil piping welded joints made by the gear manufacturer	-	X	-	-	X	<u>4/ 5/</u>
Welds, fabricated gear elements						
(a) Strength welds	X-2	-	-	-	X	<u>6/</u>
(b) All other welds	-	-	-	-	X	-
Welds, casing						
(a) Strength welds	X-3	-	-	-	X	<u>6/</u>
(b) Oil tight welds	-	-	-	X	X	-
(c) All other welds	-	-	-	-	X	-
Hubs, cast	X-VA	-	X-VA	-	X	-
Thrust bearing housing and caps	X-3	-	-	-	X	-
Lube oil sump	-	-	-	X	X	<u>7/</u>

1/ UT shall be in both radial and longitudinal directions using either a shear or longitudinal wave depending upon the geometry of the forging.

2/ Steel forgings shall be examined by the HT method; nonmagnetic materials shall be examined by the PT method.

- 3/ Inspection shall be performed after cutting or grinding teeth, as applicable, but before shot peening for through-hardened elements.
- 4/ Piping which is furnished in sections by the gear manufacturer for installation welding at the shipyard will not require hydrostatic testing by the gear manufacturer where the final assembly is pressure tested by the shipbuilder.
- 5/ Test pressure shall be a gauge pressure of 150 lb/in².
- 6/ A strength weld transmits propulsion torque or propulsion thrust.
- 7/ Test shall consist of filling sump with water or clean hot oil and visually examining for leakage. Leaks shall be cause for rejection pending corrective repairs and retest to assure a sound leak-free sump.

X - Indicates test required.

X - Followed by number indicates acceptance level.

X - Followed by VA indicates vendor levels as approved by NAVSEA

LT - Leak test (gravity)

15.3 Performing NDT inspection.

15.3.1 NDT inspection shall be performed in accordance with MIL-STD-271.

15.4 Acceptance standards for NDT inspection.

15.4.1 MT and PT inspection of welds. Inspection for surface discontinuities in welds and adjacent areas shall be performed by MT or PT method. In general, the MT method shall be used on ferrous materials and the PT method on nonferrous materials and austenitic corrosion resistant steels. Acceptance criteria for welds shall be in accordance with MIL-STD-2035.

15.4.2 MT and PT inspection of castings. There shall be 100 percent MT or PT inspection of all accessible areas for the items shown in table XXII. Acceptance standards shall be in accordance with MIL-STD-2035.

15.5 UT inspection.

15.5.1 UT inspection in accordance with an approved written test procedure and acceptance standards may be used when approved for the application.

15.6 Additional inspection for ferritic materials.

15.6.1 Ferritic castings and fabrication welds thereto which are radiographed prior to stress relief, as permitted by MIL-STD-271, shall be subjected to MT inspection after stress relief. Acceptance standards shall be as required for the parts or welds involved.

16. NDT INSPECTION REQUIREMENTS FOR FORCED DRAFT BLOWERS

16.1 General. This section contains the minimum inspection requirements for welds and casting used in the fabrication of forced draft blowers.

16.2 Inspection requirements.

16.2.1 Forced draft blower components or parts shall be inspected in accordance with table XXIII.

TABLE XXIII. NDT inspection requirements for forced draft blowers.

Part or service	MT/PT	RT	HT	UT	VT
Cylinders	-	-	X	-	X
Blade rings (compressor stator)	X-3	-	-	-	X
Packing casings	X-3	-	-	-	X
Supports, flexible	X-2	-	-	-	X
Control valves:					
Seating surface of valve and seat	X-1	-	-	-	X
Discs - turbine and propeller	X-VA	-	-	X-VA	X

X - Indicates test required

X - Followed by number indicates acceptance class

X - Followed by VA indicates vendor levels as approved by NAVSEA

16.3 Performing NDT inspection.

16.3.1 NDT inspection shall be performed in accordance with MIL-STD-271.

16.3.2 Radiographic standard shooting sketches. Shooting sketches in accordance with MIL-STD-271 shall be provided to assist in interpretation of the applicable radiographs; however, approval of the sketches is not required.

16.4 Acceptance standards for NDT inspection.

16.4.1 Radiography. Radiography of welded joints and repair welds in castings shall be compared with class 1 of MIL-STD-2035. Casting radiographs shall conform to table XVIII.

16.4.2 MT and PT inspection of welds. Inspection for surface discontinuities in welds and adjacent areas shall be performed by MT or PT method. The MT method shall be used on ferrous materials and the PT method on nonferrous materials and austenitic corrosion-resistant steels. Acceptance criteria shall be in accordance with MIL-STD-2035.

16.4.3 MT and PT inspection of castings. There shall be 100 percent MT or PT inspection of all accessible areas for items shown in table XXIII. Acceptance

standards shall be in accordance with MIL-STD-2035, except that footnote 1 of tables VI and X, therein, does not apply.

16.5 UT inspection.

16.5.1 UT inspection in accordance with an approved written test procedure and acceptance standards may be substituted for radiography when approved for application.

16.6 Additional inspection for ferritic materials.

16.6.1 Ferritic castings, and fabrication welds thereto which are subject to NDT prior to stress relief, as permitted by MIL-STD-271, shall be subjected to MT inspection after stress relief. Acceptance standards shall be as required for the parts or welds involved.

17. NOTES

17.1 Cancelled specifications. The following are cancelled or superseded specifications for materials. They are listed in this document to identify applicable requirements for welding, NDT, etc. when the materials are encountered, e.g. in existing ships, components, etc.

FEDERAL

- QQ-A-601 - Aluminum Alloy Sand Castings.
- QQ-B-637 - Brass, Naval: Rod, Wire, Shapes, Forgings, and Flat Products with Finished Edges (Bar, Flat Wire, and Strip).
- QQ-B-728 - Bronze Manganese: Rod, Shapes, Forgings, and Flat Products (Flat Wire, Strip, Sheet, Bar, and Plate).
- QQ-B-750 - Bronze, Phosphor: Bar, Plate, Rod, Sheet, Strip, Flat Wire, and Structural and Special Shaped Sections.
- QQ-C-465 - Copper-Aluminum Alloys (Aluminum Bronze) (Copper Alloy Numbers 606, 614, 630, 632M, and 642): Rod, Flat products with Finished Edges (Flat Wire, Strip, and Bar); Shapes, and Forgings.
- QQ-C-576 - Copper Flat products with Slit, Slit and Edge-Rolled, Sheared, Sawed, or Machined Edges, (Plate, Bar, Sheet, and Strip).
- QQ-C-591 - Copper-Silicon, Copper-Zinc-Silicon, and Copper-Nickel-Silicon Alloys: Rod, Wire, Shapes, Forgings, and Flat products (Flat Wire, Strip, Sheet, Bar, and Plate).
- QQ-E-450 - Electrode, Welding, Covered: Mild Steel.
- QQ-N-288 - Nickel-Copper Alloy and Nickel-Copper-Silicon Alloy Castings.
- QQ-S-766 - Steel, Stainless and Heat Resisting, Alloys, Plate, Sheet, and Strip.
- WW-T-799 - Tube, Copper, Seamless, Water (For Use with Solder-Flared or Compression Type Fittings).

MILITARY

- MIL-S-860 - Steel Forgings for Steam Turbine Rotors.
- MIL-S-861 - Steel Bars, Corrosion Resisting, Naval Steam Turbine Parts Use.
- MIL-S-862 - Steel Bars, Corrosion Resisting, and Steel Billets, Corrosion Resisting; Reforging Application.
- MIL-S-867 - Steel Castings, Corrosion Resisting Austenitic.
- MIL-S-870 - Steel Castings, Molybdenum Alloy.
- MIL-S-872 - Steel Bars, Billets, and Forgings-Carbon-Molybdenum Alloy.
- MIL-P-1144 - Pipe, Corrosion-Resistant, Stainless Steel, Seamless or Welded.

S9074-AR-GIB-010/278

- MIL-S-8699 - Steel Bars and Forging Stock (4330) Vanadium Modified, Aircraft Quality.
- MIL-S-15083 - Steel Casings.
- MIL-C-15345 - Castings, Nonferrous, Centrifugal.
- MIL-S-15464 - Steel, Alloy, Chromium-Molybdenum; Castings.
- MIL-B-16541 - Bronze, Valve; Castings.
- MIL-S-16974 - Steel Bars, Billets, Blooms and Slabs; Carbon and Alloy (for Reforging or Other Operations Before Heat Treatment).
- MIL-S-16993 - Steel Castings (12-Percent Chromium).
- MIL-T-17188 - Tube, Carbon Steel, Electric Resistance Welded, Marine Boiler.
- MIL-S-17509 - Steel Castings, Austenitic, Chromium-Nickel, Low Magnetic Permeability.
- MIL-S-18410 - Steel Bars, Billets, and Forgings - Chromium-Molybdenum Alloy.
- MIL-T-18165 - Tube and Pipe, Chromium-Molybdenum Alloy Steel, Seamless.
- MIL-S-20154 - Steel: Plate, Special Treatment, For Protective Hull Plating.
- MIL-T-20155 - Tube and Pipe, Carbon-Molybdenum Alloy Steel, Seamless (ASTM-A-335-55T, Grade P-1)
- MIL-T-20157 - Tube and Pipe, Carbon Steel, Seamless.
- MIL-C-20159 - Copper-Nickel Alloy Castings (UNS No. C96200 and C96400).
- MIL-T-20168 - Tubes, Brass, Seamless.
- MIL-B-21230 - Bronze, Nickel Aluminum and Manganese-Nickel Aluminum; Castings, Ship Propeller Application.
- MIL-S-24412 - Steel, Special Structural Shape, Weldable, High Tensile (HT); for Submarine Hulls.
- MIL-B-24059 - Bronze, Nickel Aluminum; Rod, Flat Products with Finished Edges, Shapes, and Forgings.

APPENDIX A

ADDITIONAL REQUIREMENTS FOR WELDING TITANIUM AND TITANIUM ALLOYS

10. SCOPE

10.1 This appendix contains additional requirements for a fabrication plan, personnel and production testing of welds for titanium fabrication.

20. REFERENCED DOCUMENTS

20.1 This section is not applicable.

30. APPROVAL FOR FABRICATION AND WELDING

30.1 Fabrication plan. Activities, including all involved subcontractors, seeking to fabricate (i.e., weld, repair weld, heat treat, form, or machine in preparation for welding) S-51, S-52, and S-53 materials shall prepare a written fabrication plan that describes, in detail, all controls for ensuring the quality and integrity of the fabricated product. This plan shall describe and assign duties and responsibilities for each aspect of fabrication and quality assurance. The plan shall include:

- (a) Fabrication design. Components and systems fabricated of S-51, S-52, and S-53 materials shall be specifically designed to ensure that location of welds, assembly of subcomponents, etc. are such that all welding is performed in the shop to the maximum extent practicable, and that shipboard welding is minimized. In addition all shipboard welds shall be designed to ensure that location affords good welder access (considering trailing shields, etc.) and that consideration is given to purging access, obtaining requisite fit-up, practicality of establishing temporary areas for cleanliness (See 30.2), and all other requirements of this document.
- (b) Workmanship and inspection acceptance standards. The standards for acceptance of materials on receipt and in all stages of processing shall be stated. Included shall be all requirements for alloy composition and condition in all forms, cleaning procedures for welding electrodes and weld joints, shielding gas purity and weld coverage through trailing and backing shields, weld contamination color standards, specific weld joint designs, preparation, alignment and tooling for erection, weld repair, and nondestructive inspection.
- (c) Forming and heat treating. Details of the forming and heat treating procedures, including sequencing and inspection, shall be provided. Qualification of the procedure, verification of results and provision for process control in production shall be reviewed for approval by NAVSEA.
- (d) Safety. Procedures for the safe collection, storage and disposal of titanium chips and dust resulting from machining and grinding operations shall be established. Included shall be plans for fire prevention and

fighting of fires in titanium fines. Safe handling, storage, and disposal methods for solvents shall be referenced.

This plan shall be submitted for review and written notification of acceptance shall be received from NAVSEA prior to the start of fabrication. Any proposed technical changes to the plan shall be promptly provided to NAVSEA for review. Where evidence is provided to show that similar fabrications have been previously produced to this document or that the activity has extensive titanium fabricating experience, NAVSEA may, at its discretion, accept procedures established by that activity in lieu of all or portions of the requirements of this paragraph.

30.2 Facilities. The activity and/or its subcontractor(s) shall prepare and obtain NAVSEA approval of a procedure that establishes facility requirements for the fabrication of titanium. This procedure shall include the controls to be established for the welding and fabrication of titanium to preclude contamination. Although, the use of a dedicated facility is recommended, the activity may establish temporary fabrication areas for titanium welding. The procedure shall address: equipment necessary for materials handling, environmental control, welding, machining, conditioning and cleaning, inert gas distribution, heat treating, and nondestructive evaluation. The procedure shall provide requirements that ensure that the welding area is restricted from general traffic, and is protected from winds and draft, dirt, smoke, grinding residues, welding and machining operations on other materials, and other airborne contaminants. All equipment to be used in the titanium welding area shall be blown clean and wiped to remove accumulated dust and dirt before being brought into that area. Pneumatic tools shall not be used in the area of welding or fabrication operations unless requirements specified in the procedure preclude contamination of welds, base materials, and filler materials. A regular scheduled cleanup of welding areas and temporary areas (while maintained for use) shall be established. Clean up is to include use of vacuum cleaners exhausting outside the area rather than items such as brooms. Controls for the use of nondedicated materials, equipment, and facilities (e.g., preheat furnace for hot forming) shall also be included in the procedure to ensure that such use does not contaminate the titanium or titanium alloy.

30.2.1 Materials. All materials involved in the fabrication or inspection of titanium and titanium alloys, including consumables such as shielding gases, cleaning agents, and dye penetrants, shall be certified as to purity and conformance to specification and/or fabrication plan. Shielding and purge gases shall be argon, helium or mixture thereof. All shielding and purge gases used for welding or for heat treating (vacuum furnace purging) shall have (1) a purity of at least 99.995 percent and (2) a dew point of -60°F or less at the work piece (weld) or purge exit. Shielding gas hoses for welding shall be new or shall have been used to carry inert welding shielding gas only. Records of certification shall be maintained.

30.2.1.1 Dew point of shielding and purge gases shall be tested at the beginning of each shift or whenever gas flow is interrupted, except as follows: dew point shall be verified for each weld and repair weld that is not inspected on the backside per 10.3.13 because of inaccessibility.

30.2.1.2 Stainless steel brushes used for cleaning shall be free of any

contaminant and shall be used only on titanium and titanium alloy.

30.2.1.3 The cleaning solvent used shall be acetone, Alcohol Formula 23, isopropyl alcohol or other nonhalogenated solvent proven to have no potential adverse affect on titanium.

30.2.1.4 All tooling for fabrication used on the final surface such as bending dies and mandrels, machine carbide bits, carbide grinding burrs, etc. shall be only used for titanium.

30.3 Personnel. All personnel working with titanium and titanium alloys shall be given formal instruction, within the limits of their discipline, on procedures for handling these materials to avoid inadvertent contamination and to attain the highest quality product. Included shall be: riggers and other materials handlers, machinists, heat treaters, spinners, forgers and press operators, welders, grinders, nondestructive evaluation personnel, the various inspectors responsible for work performance, and materials/welding engineers in production or support positions. Records of personnel training and test results shall be maintained with appropriate review to keep qualification current. A training plan, including methods of review to ensure continuous compliance, shall be submitted for NAVSEA approval.

30.3.1 Welders. Qualified welders and welding operators should not be assigned to weld other materials during the time period that they are engaged in production welding of titanium.

40. PRODUCTION TESTING OF S-51, S-52, AND S-53 WELDS.

40.1 Bend testing of welds in class A components. For class A-F, A-1, A-2 and A-3 pressure vessels and having locations A or B type welds as described in this section, a production test plate of the same specification, grade, and thickness shall be made of sufficient size to provide at least one face and one root bend specimen or two side bend specimens, dependent on plate thickness. Where longitudinal joints are involved, the test plate shall be attached by welding to one end of the longitudinal joint and welded continuously with the joint. Where circumferential joints are involved, the test plate need not be attached but shall be welded along with the joint and each welder or welding operator shall deposit weld metal in the test plate at the location and proportional to that deposited in the production weld. Test plates shall represent each welding process or combination of processes or change from machine to manual or vice versa. At least one test plate is required for each vessel provided not over 100 ft. of Location A or B joints are involved. An additional test plate, meeting the same requirements, as above, shall be made for each additional 100 ft. or portion thereof of Location A or B joints involved. The bend specimens shall be prepared and tested in accordance with MIL-STD-248 and shall meet the requirements therein. Failure of either bend specimen constitutes rejection of the weld.

40.1.1 Welded Joint Location. The location of a welded joint in a vessel defines the placement but not the type of joint. This paragraph establishes joint locations for use in specifying special joint type requirements and degree of inspection of certain welded pressure joints. Since these special requirements,

which are based on service, material, and thickness, do not apply to every welded joint in all classes of vessels, only those joints to which special requirements apply are included. Figure 4 illustrates typical joint orientations and placements included in Locations A, B, C, and D, as described below.

40.1.1.1 Locations A. Longitudinal weld joints within the main shell, communicating chambers, transitions in diameter, or nozzles; any weld joint within a sphere, within a formed or flat head, or within the side plates of a flat sided vessel; circumferential welded joints connecting hemispherical heads to main shells, to transitions in diameter, to nozzles, or to communicating chambers.

- Notes: 1. Communicating chambers are defined as appurtenances to the vessel which intersect the shell or heads of a vessel and form an integral part of the pressure containing enclosure, e.g., sumps.
2. Side plates of a flat sided vessel are defined as any of the flat plates forming an integral part of the pressure containing enclosure.

40.1.1.2 Locations B. Circumferential welded joints within the main shell, communicating chambers, nozzles, or transitions in diameter including joints between the transition and a cylinder at either the large or small end; circumferential welded joints connecting formed heads other than hemispherical to main shells, to transitions in diameter to nozzles, or to communicating chambers.

40.1.1.3 Locations C. Welded joints connecting flanges, Van Stone laps, tube sheets, or flat heads to main shell, to formed heads, to transitions to diameter, to nozzles, connecting one side plate, to another side plate of a flat-sided vessel.

40.1.1.4 Locations D. Welded joints connecting communicating chambers or nozzles to main shells, to spheres, to transitions in diameter, to heads, or to flat-sided vessels, and those joints connecting nozzles to communicating chambers (for nozzles at the small end of a transition in diameter, see Locations B).

40.1.2 When butt welded joints are required elsewhere in this document for Locations B, an angle joint connecting a transition in diameter to a cylinder shall be considered as meeting this requirement provided the angle, α (see Figure 4) does not exceed 30 degrees. All requirements pertaining to the butt welded joint shall apply to the angle joint.

40.1.3 Test results shall be recorded and signed by the activity's responsible official. Records shall be identifiable to the vessel and welds they represent and shall include date of tests and bend radius. Records shall be maintained along with other documentation required herein.

40.2 Testing of Welds in Other than Class A Components.

40.2.1 Each welder and welding operator qualified for pipe shall satisfactorily complete one pipe test coupon for visual and color inspection and

Bend testing as described below. Each coupon shall be completed at intervals of not less than 60 days nor greater than 92 days. Visual and color inspection of individual passes and final weld surfaces (inside and outside) shall be performed per the requirements of this document. Any occurrence of unacceptable color except for straw or very light blue shall cause rejection of the coupon. Bend specimens shall be prepared and tested in accordance with MIL-STD-248. Welding of the test coupon shall conform to the following:

- a. The coupon shall be a full penetration butt joint design of MIL-STD-22 and represent the upper range of thickness welded by the welder in the last three months, or 1/4 inch whichever is less. A backing ring joint design shall not be employed unless the person is only qualified for backing ring joints. For personnel not having butt weld qualifications, an alternate testing method that includes macro and hardness testing can be submitted for NAVSEA approval, or the requirements of this section shall be met.
- b. The coupon shall be large enough to provide necessary bend specimens (one face and one root bend specimen).
- c. The coupon shall be welded in the production environment alongside a production weld following the production welding procedure. The same welding equipment, base metal grade, base metal preparation processes, filler material, and inert gas distribution system as used in production welding shall be used for the coupon. Preparation and fit-up of the coupon shall be performed by the same personnel performing these operations for production welds.
- d. The coupon may be welded in any position.
- e. Subject to g. below, a welder who uses more than one welding process, may use any one of the processes for which he is qualified to weld the coupon.
- f. Subject to g. below, the test coupon should be welded using the manual process where the welder used both manual and automatic processes in production. Also if the welder is engaged in shipboard welding, the coupon should be scheduled so as to be completed shipboard.
- g. The activity shall structure the welding of coupons so that all welding areas and equipment used for production welding are regularly employed for making test coupons from time to time.
- h. If there is no production welding at the end of 92 days, the welder shall make a test coupon whenever the next production welding is started.

40.2.1.1 Except as permitted below, if the test coupon fails, the activity shall ascertain the cause of the failure and correct it and the welder is permitted to repeat the test coupon once. Failure of the second test coupon terminates all the welder's qualifications for titanium and full requalification is required. If the failure is due to a weld defect only, one bend specimen failure per test coupon is permitted provided two additional bend specimens of the same type are removed

from the coupon and are satisfactorily tested per MIL-STD-248.

40.2.1.2 The activity's methods and controls for accomplishing coupon testing shall be described in a written procedure. Records of test results signed by the activity's responsible official, shall be maintained for all welders for the preceding 12 months. Records shall include base material grade and thickness, welding process, bend radius, location of test (shipboard, shop, etc.) test date, results and welder's name.

40.2.1.3 Activities exclusively welding piping or tubing of sizes less than 1-1/2 inch nps are exempt from the requirements of 40.2.1.

40.2.2 For welding other than pipe, as covered by 40.2.1, and pressure vessels, as covered by 40.1, the following shall apply: Testing is not required for class M, category C welds. For personnel performing welding of casting fabrication welds or fabrication welds in other components covered by this document, testing per 40.2.1 shall also be performed except that plate may be used in lieu of pipe. Alternatively, bend testing per 40.1 may be performed for each component. Activities exclusively performing repair welding of castings or producing components made by automatic welding processes in a chamber, or vacuum, of materials less than 1/8 inch thickness are exempt from these requirements.

40.2.3 As an alternate to 40.2.1 or 40.2.2, sampling of in process and final weld hardness in accordance with methods and procedures approved by NAVSEA may be performed.

See 40.1.2, Appendix A

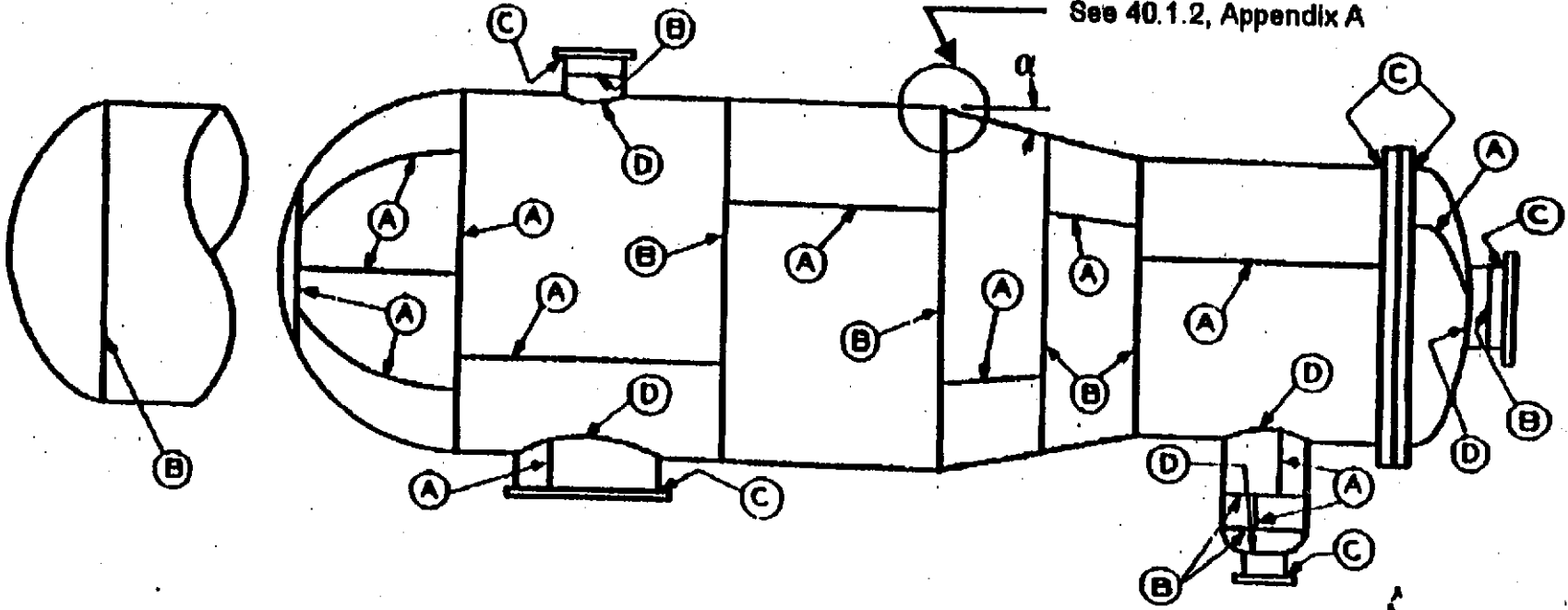

Figure 4. Illustration of Welded Joint Locations

S9074-AR-GIB-010/278

Original 142

NAVSEA/SPAWAR TECHNICAL MANUAL DEFICIENCY/EVALUATION REPORT (TMDER)

INSTRUCTIONS: Continue on 8 1/2" x 11" on page if additional space is needed.

1. Use this report to indicate deficiencies, problems and recommendations relating to publications.
2. For **CLASSIFIED** TMDERs see OPNAVINST 5510H for mailing requirements.
3. For TMDERs that affect more than one publication, submit a separate TMDER for each.
4. Submit TMDERs at web site <https://nsdsa.nmci.navy.mil> or mail to: **COMMANDER, CODE 310 TMDERs, NAVSURFWARCENDIV NSDSA, 4363 MISSILE WAY BLDG 1389, PORT HUENEME CA 93043-4307**

1. PUBLICATION NUMBER	2. VOL/PART	3. REV/DATE OR CHG/DATE	4. SYSTEM/EQUIPMENT ID
-----------------------	-------------	-------------------------	------------------------

5. TITLE OF PUBLICATION	6. REPORT CONTROL NUMBER (6 digit UIC-YY-any four: xxxxxx-10-xxxx)
-------------------------	---

7. RECOMMEND CHANGES TO PUBLICATION

7a. Page #	7b. Para #	7c. RECOMMENDED CHANGES AND REASONS

8. ORIGINATOR'S NAME AND WORK CENTER	9. DATE	10. ORIGINATOR'S E-MAIL ADDRESS	11. TMMA of Manual (NSDSA will complete)
--------------------------------------	---------	---------------------------------	---

12. SHIP OR ACTIVITY Name and Address (Include UIC/CAGE/HULL)	13. Phone Numbers: Commercial () ___-____ DSN ___-____ FAX () ___-____
---	---

FOLD HERE AND TAPE SECURELY
PLEASE DO NOT STAPLE

INCLUDE COMPLETE ADDRESS

USE
PROPER
POSTAGE

FOR OFFICIAL USE ONLY

**COMMANDER
CODE 310 TMDERs
NAVSURFWARCENDIV NSDSA
4363 MISSILE WAY BLDG 1389
PORT HUENEME CA 93043-4307**

FOLD HERE AND TAPE SECURELY
PLEASE DO NOT STAPLE