

T9074-BD-GIB-010/0300

REVISION 2

NAVSEA TECHNICAL PUBLICATION

**BASE MATERIALS FOR CRITICAL APPLICATIONS:
REQUIREMENTS FOR LOW ALLOY STEEL PLATE,
FORGINGS, CASTINGS, SHAPES, BARS, AND HEADS
OF HY-80/100/130 AND HSLA-80/100**



THIS REVISION SUPERSEDES T9074-BD-GIB-010/0300 REVISION 1 DATED 16 JULY 2012.

DISTRIBUTION STATEMENT A: APPROVED FOR PUBLIC RELEASE; DISTRIBUTION UNLIMITED.

PUBLISHED BY DIRECTION OF COMMANDER, NAVAL SEA SYSTEMS COMMAND

0910-LP-112-9925



T9074-BD-GIB-010

18 DECEMBER 2012

T9074-BD-GIB-010/0300 Rev 2

LIST OF EFFECTIVE PAGES

Dispose of superseded pages in accordance with applicable regulations.

Dates of issue for original and subsequent revisions:

Original.....	9 August 2002
Revision 1.....	16 July 2012
Revision 2.....	18 December 2012

TOTAL NUMBER OF PAGES IN THIS PUBLICATION IS 228, CONSISTING OF THE FOLLOWING:

Page No.	Page No.
Title	C-1 through C-10
A	D-1 through D-15
i through xxxvi	D-16 blank
1-1	E-1 through E-15
1-2 blank	E-16 blank
2-1 through 2-3	F-1 through F-19
2-4 blank	F-20 blank
3-1 through 3-5	G-1 through G-9
3-6 blank	G-10 blank
4-1 through 4-5	H-1 through H-8
4-6 blank	I-1 through I-10
5-1	J-1 through J-3
5-2 blank	J-4 blank
6-1	K-1 and K-2
6-2 blank	L-1 through L-20
A-1 through A-24	M-1 and M-2
B-1 through B-22	

NAVSEA TECHNICAL PUBLICATION CERTIFICATION SHEET				1 of 1	
Certification Applies to:		New Document <input type="checkbox"/>	Revision <input checked="" type="checkbox"/>	Change <input type="checkbox"/>	
Applicable TMIN/Pub. No.	T9074-BD-GIB-010/0300 Rev 2				
Publication Date (Mo, Day, Yr)	18 December 2012				
Title: BASE MATERIALS FOR CRITICAL APPLICATIONS: REQUIREMENTS FOR LOW ALLOY STEEL PLATE, FORGINGS, CASTINGS, SHAPES, BARS, AND HEADS OF HY-80/100/130 AND HSLA-80/100					
CHANGES AND REVISIONS					
Purpose: This revision corrects inconsistencies, omissions, and errors. This revision also provides updates with regard to specification improvements, technology developments, and lessons learned. This revision reflects input from producers as well as from public and private shipbuilders.					
TMDER/ACN Numbers Incorporated: None					
<i>Continue on reverse side or add pages as needed</i>					
CERTIFICATION STATEMENT					
This is to certify that responsible NAVSEA activities have reviewed the above identified document for technical adequacy and suitability for the intended use. This form is for internal NAVSEA management use only, and does not imply contractual approval or acceptance of the technical publication by the Government.					
Name	Signature	Organization	Code	Date	
Joseph M. Blackburn		NAVSEA	05P2	12/18/2012	

TABLE OF CONTENTS

Paragraph	Title	Page
CHAPTER 1 SCOPE.....		1-1
1.1 SCOPE.....		1-1
1.2 CLASSIFICATION.....		1-1
CHAPTER 2 APPLICABLE DOCUMENTS		2-1
2.1 GENERAL.....		2-1
2.2 GOVERNMENT DOCUMENTS.....		2-1
2.2.1 Specifications, Standards, and Handbooks.....		2-1
2.2.2 Other Government Documents, Drawings, and Publications.....		2-1
2.3 NON-GOVERNMENT PUBLICATIONS.....		2-2
2.4 ORDER OF PRECEDENCE.....		2-3
CHAPTER 3 REQUIREMENTS		3-1
3.1 FIRST ARTICLE.....		3-1
3.2 MATERIAL.....		3-1
3.2.1 Recycled, Recovered, or Environmentally Preferable Materials.....		3-1
3.2.2 Ingot Discard.....		3-1
3.3 CHEMICAL COMPOSITION.....		3-1
3.4 MECHANICAL PROPERTIES.....		3-1
3.5 HEAT TREATMENT.....		3-1
3.5.1 Heat Treatment Equipment and Controls.....		3-1
3.5.2 Heat Treatment Record.....		3-2
3.5.3 Working Zone Temperature Survey.....		3-2
3.5.4 Load Distribution.....		3-2
3.5.5 Quenchant Temperature.....		3-2
3.5.6 Contact Thermocouples.....		3-2
3.6 SURFACE QUALITY.....		3-2
3.7 DIMENSIONS AND TOLERANCES.....		3-2
3.8 IDENTIFICATION MARKING.....		3-2
3.9 DESCALING AND CLEANING.....		3-2
3.10 INTERNAL SOUNDNESS.....		3-2
3.11 EXPLOSION TESTING.....		3-2
CHAPTER 4 VERIFICATION		4-1
4.1 RESPONSIBILITY FOR INSPECTION.....		4-1
4.1.1 Performance of Inspection.....		4-1
4.1.2 Examination of Material as Offered for Acceptance.....		4-1
4.1.3 Quality System.....		4-1
4.1.3.1 Traceability System.....		4-1

T9074-BD-GIB-010/0300 Rev 2

Paragraph	Title	Page
4.1.4	Product Quality Requirements.....	4-1
4.1.5	Responsibility for Compliance.....	4-1
4.1.6	Certification of Conformance.....	4-1
4.2	CLASSIFICATION OF INSPECTIONS.....	4-1
4.3	FIRST ARTICLE INSPECTION.....	4-2
4.3.1	Sampling for First Article Inspection.....	4-2
4.3.2	Process Control Plan.....	4-2
4.3.2.1	Process Control Plan Contents.....	4-2
4.3.3	Re-Certification of First Article Approval.....	4-3
4.4	CONFORMANCE INSPECTION.....	4-3
4.4.1	Lot Definitions.....	4-3
4.4.1.1	Lot for Chemical Composition.....	4-3
4.4.1.2	Lot for Tension Tests.....	4-3
4.4.1.3	Lot for Impact Tests.....	4-3
4.4.1.4	Lot for Examination and Inspections.....	4-3
4.4.2	Sampling.....	4-3
4.4.2.1	Sampling for Examination.....	4-3
4.4.2.2	Sampling for Chemical and Spectrographic Analysis.....	4-3
4.4.2.3	Sampling for Tensile Test.....	4-3
4.4.2.4	Sampling for Impact Test.....	4-4
4.4.2.5	Marking of Test Specimens.....	4-4
4.4.3	Examination.....	4-4
4.5	TEST PROCEDURES.....	4-4
4.5.1	Chemical or Spectrographic Analysis.....	4-4
4.5.2	Tensile Test.....	4-4
4.5.3	Charpy V-Notch Impact Test.....	4-4
4.5.4	Dynamic Tear Impact Test.....	4-4
4.5.5	Explosion Tests.....	4-4
4.6	REJECTION AND RETESTS.....	4-4
4.6.1	Reheat Treatment.....	4-4
4.6.2	Tensile Retest.....	4-5
4.6.2.1	Gauge Length Retest.....	4-5
4.6.3	Charpy V-Notch Retest.....	4-5
4.6.4	Dynamic Tear Retest.....	4-5
4.6.5	Defective Specimen/Replacement of Test Specimens.....	4-5
CHAPTER 5	PACKAGING.....	5-1
5.1	PREPARATION FOR PACKAGING AND PACKING.....	5-1
5.2	PACKAGING, PACKING, AND MARKING FOR SHIPMENT.....	5-1
5.3	PACKAGING BY DOD PERSONNEL.....	5-1
CHAPTER 6	NOTES.....	6-1

Paragraph	Title	Page
6.1	INTENDED USE	6-1
6.2	ACQUISITION REQUIREMENTS.....	6-1
6.3	FIRST ARTICLE	6-1
6.3.1	New Vendors	6-1
6.3.2	Forwarding Data	6-1
6.3.3	Manufacturing and Testing.....	6-1
6.3.4	Currently Qualified Vendors to Previous Specifications.....	6-1
APPENDIX A (24645) STEEL PLATE, SHEET, OR COIL, AGE-HARDENING ALLOY, STRUCTURAL, HIGH YIELD STRENGTH (HSLA-80 AND HSLA-100).....		A-1
A.1	SCOPE.....	A-1
A.1.1	Scope.....	A-1
A.1.2	Classification	A-1
A.2	APPLICABLE DOCUMENTS	A-1
A.3	REQUIREMENTS.....	A-1
A.3.1	Material.....	A-1
A.3.2	Chemical Composition.....	A-2
A.3.3	Tensile Properties	A-3
A.3.4	Impact Properties	A-4
A.3.5	Heat Treatment	A-4
A.3.5.1	Thermal Hydrogen Soak After Hot Rolling.....	A-5
A.3.6	Surface Quality	A-5
A.3.6.1	Weld Repair of Mill Defects After Heat Treatment.....	A-5
A.3.6.1.1	Weld Repairs of Mill Defects Prior to Heat Treatment.....	A-6
A.3.6.2	Edge Defects	A-6
A.3.7	Dimensional Tolerances.....	A-6
A.3.7.1	Tolerances for Material Less than $\frac{3}{16}$ Inch (4.8 mm) in Thickness	A-6
A.3.7.2	Alternate Dimensional Tolerances.....	A-6
A.3.7.3	Thickness, Weight, and Gauge	A-6
A.3.7.4	Flatness	A-10
A.3.7.5	Camber.....	A-10
A.3.7.6	Size Tolerances.....	A-10
A.3.8	Internal Soundness and Thickness	A-15
A.3.8.1	Recording of Thickness Measurements and Internal Soundness Results.....	A-15
A.3.9	Applicable Fabrication Document	A-15
A.3.10	Cleaning and Preservation of Plate, Sheet, or Coil Surfaces.....	A-15
A.3.11	Marking.....	A-15
A.3.12	Explosion Testing	A-15
A.3.13	Drop Weight Nil-Ductility Test	A-15
A.4	VERIFICATION	A-15
A.4.1	Responsibility for Inspection	A-15

T9074-BD-GIB-010/0300 Rev 2

Paragraph	Title	Page
A.4.2	Classification of Inspections.....	A-15
A.4.3	First Article Inspection.....	A-15
A.4.3.1	Sampling for First Article Inspection.....	A-15
A.4.4	Conformance Inspection.....	A-16
A.4.4.1	Lot Definitions.....	A-16
A.4.4.1.1	Lot for Chemical Analysis.....	A-16
A.4.4.1.2	Lot for Tension Tests.....	A-16
A.4.4.1.3	Lot for Impact Tests.....	A-16
A.4.4.1.4	Lot for Examination and Inspections.....	A-16
A.4.4.2	Sampling for Conformance Inspection.....	A-16
A.4.4.2.1	Location of Test Specimens in Plate, Sheet, or Coil.....	A-16
A.4.4.2.2	Sampling for Chemical or Spectrographic Analysis.....	A-16
A.4.4.2.3	Sampling for Tensile Test.....	A-16
A.4.4.2.4	Sampling for Impact Test.....	A-16
A.4.4.2.4.1	Sampling for Charpy V-Notch Impact Test.....	A-16
A.4.4.2.4.2	Sampling for Dynamic Tear Impact Test.....	A-17
A.4.4.2.5	Thermal Buffer Pad Requirements.....	A-17
A.4.4.2.6	Sampling for Thickness Testing.....	A-17
A.4.5	Visual Examination.....	A-17
A.4.6	Test Procedures.....	A-17
A.4.6.1	Chemical Analysis.....	A-17
A.4.6.2	Tensile Test.....	A-17
A.4.6.3	Impact Toughness.....	A-17
A.4.6.3.1	Charpy V-Notch Impact Test.....	A-17
A.4.6.3.2	Dynamic Tear Impact Test.....	A-17
A.4.6.3.3	Drop Weight Nil-Ductility Test.....	A-17
A.4.6.3.4	Marking of Test Specimens.....	A-17
A.4.6.4	Gauging.....	A-17
A.4.6.5	Ultrasonic Examination.....	A-17
A.4.6.5.1	Ultrasonic Soundness.....	A-17
A.4.6.5.2	Ultrasonic Thickness.....	A-18
A.4.6.6	Documentation.....	A-18
A.4.6.7	Microstructure Analysis.....	A-18
A.4.6.7.1	Prior Austenite Grain Size.....	A-18
A.4.6.7.2	Microstructure.....	A-18
A.4.6.8	Explosion Test.....	A-18
A.5	PACKAGING.....	A-18
A.6	NOTES.....	A-18
A.6.1	Intended Use.....	A-18
A.6.2	Acquisition Requirements.....	A-18

Paragraph	Title	Page
A.6.3	Thin Plates.....	A-19
A.6.4	First Article.....	A-19
A.6.5	Receipt Inspection.....	A-19
APPENDIX B (16216) STEEL PLATE, ALLOY, STRUCTURAL, HIGH YIELD STRENGTH (HY-80 and HY-100)....		B-1
B.1	SCOPE.....	B-1
B.1.1	Scope.....	B-1
B.1.2	Classification.....	B-1
B.2	APPLICABLE DOCUMENTS.....	B-1
B.3	REQUIREMENTS.....	B-1
B.3.1	Material.....	B-1
B.3.2	Chemical Composition.....	B-1
B.3.3	Tensile Properties.....	B-2
B.3.3.1	Ultimate Tensile Strength.....	B-2
B.3.4	Impact Tests.....	B-3
B.3.4.1	Impact Properties.....	B-3
B.3.5	Heat Treatment.....	B-4
B.3.5.1	Thermal Hydrogen Soak After Hot Rolling.....	B-5
B.3.5.2	Simulated Stress Relief.....	B-5
B.3.6	Surface Quality.....	B-5
B.3.6.1	Weld Repair of Mill Defects After Heat Treatment.....	B-6
B.3.6.1.1	Weld Repairs of Mill Defects Prior to Heat Treatment.....	B-6
B.3.6.2	Edge Defects.....	B-6
B.3.7	Internal Soundness and Thickness.....	B-6
B.3.7.1	Recording of Thickness Measurements and Internal Soundness Results.....	B-6
B.3.8	Applicable Fabrication Document.....	B-7
B.3.9	Dimensional Tolerances.....	B-7
B.3.9.1	Thickness, Weight, and Gauge.....	B-7
B.3.9.2	Flatness.....	B-7
B.3.9.3	Camber.....	B-7
B.3.9.4	Size Tolerances.....	B-7
B.3.10	Cleaning and Preservation of Plate Surfaces.....	B-7
B.3.11	Marking.....	B-7
B.3.12	Explosion Testing.....	B-7
B.4	VERIFICATION.....	B-14
B.4.1	Responsibility for Inspection.....	B-14
B.4.2	Classification of Inspections.....	B-14
B.4.3	First Article Inspection.....	B-14
B.4.4	Conformance Inspection.....	B-15
B.4.4.1	Lot Definitions.....	B-15
B.4.4.1.1	Lot for Chemical or Spectrographic Analysis.....	B-15

T9074-BD-GIB-010/0300 Rev 2

Paragraph	Title	Page
B.4.4.1.2	Lot for Tension Tests.....	B-15
B.4.4.1.3	Lot for Impact Tests.....	B-15
B.4.4.1.4	Lot for Examination and Inspections.....	B-15
B.4.4.2	Sampling for Conformance Inspection.....	B-15
B.4.4.2.1	Location of Test Specimens in Plate.....	B-15
B.4.4.2.2	Sampling for Chemical or Spectrographic Analysis.....	B-15
B.4.4.2.3	Sampling for Tensile Test.....	B-15
B.4.4.2.4	Sampling for Impact Test.....	B-15
B.4.4.2.4.1	Charpy V-Notch Specimen.....	B-15
B.4.4.2.4.2	Dynamic Tear Specimen.....	B-16
B.4.4.2.5	Sampling for Mechanical Properties After Simulated Stress Relief.....	B-16
B.4.4.2.6	Thermal Buffer Pad Requirements.....	B-16
B.4.4.2.7	Marking of Test Specimens.....	B-16
B.4.5	Visual Examination.....	B-16
B.4.6	Test Procedures.....	B-16
B.4.6.1	Chemical or Spectrographic Analysis.....	B-16
B.4.6.1.1	Continuous Cast Slabs.....	B-16
B.4.6.2	Tensile Tests.....	B-16
B.4.6.3	Impact Toughness.....	B-16
B.4.6.3.1	Charpy V-Notch Test.....	B-16
B.4.6.3.2	Percent Shear Fracture.....	B-16
B.4.6.3.3	Dynamic Tear Test.....	B-16
B.4.6.4	Gauging.....	B-16
B.4.6.5	Ultrasonic Examination.....	B-16
B.4.6.5.1	Ultrasonic Soundness.....	B-16
B.4.6.5.2	Ultrasonic Thickness.....	B-16
B.4.6.6	Documentation.....	B-16
B.5	PACKAGING.....	B-17
B.6	NOTES.....	B-17
B.6.1	Intended Use.....	B-17
B.6.2	Acquisition Requirements.....	B-17
B.6.3	Thin Plates.....	B-17
B.6.4	First Article.....	B-17
B.6.4.1	First Article Approval.....	B-17
B.6.4.2	Ingot or Continuous Casting Process.....	B-17
B.6.5	Receipt Inspection.....	B-17
B.6.6	Dynamic Tear.....	B-18
APPENDIX C (24512)	STEEL FORGINGS, ALLOY, STRUCTURAL, HIGH YIELD STRENGTH (HY-130).....	C-1
C.1	SCOPE.....	C-1
C.1.1	Scope.....	C-1

Paragraph	Title	Page
C.2	APPLICABLE DOCUMENTS.....	C-1
C.3	REQUIREMENTS.....	C-1
C.3.1	Forging Process.....	C-1
C.3.1.1	Bored Forgings.....	C-1
C.3.2	Chemical Composition.....	C-1
C.3.3	Tensile Properties.....	C-2
C.3.4	Impact Requirements.....	C-2
C.3.4.1	Alternative Impact Requirements.....	C-2
C.3.5	Heat Treatment.....	C-2
C.3.5.1	Reheat Treatment.....	C-3
C.3.6	Stress Relief.....	C-3
C.3.7	Cleaning.....	C-3
C.3.8	Dimensions and Tolerances.....	C-3
C.3.9	Soundness.....	C-3
C.3.9.1	Magnetic Particle Inspection.....	C-3
C.3.9.2	Ultrasonic Inspection.....	C-3
C.3.9.3	Macroscopic Examination.....	C-3
C.3.10	Defect Repair.....	C-3
C.3.11	Marking.....	C-3
C.3.12	Explosion Testing.....	C-3
C.3.13	Forging Sketches.....	C-4
C.4	VERIFICATION.....	C-4
C.4.1	Responsibility for Inspection.....	C-4
C.4.2	Classification of Inspections.....	C-4
C.4.3	First Article Inspection.....	C-4
C.4.3.1	First Article Samples.....	C-4
C.4.3.1.1	Forgings.....	C-4
C.4.3.1.2	Test Prolongations.....	C-4
C.4.3.1.2.1	Prolongation Size.....	C-4
C.4.3.1.3	Explosion Test Specimens.....	C-4
C.4.3.1.4	Test Specimen Location.....	C-4
C.4.3.1.4.1	Charpy V-Notch Test.....	C-5
C.4.3.1.4.2	Chemical Analysis.....	C-5
C.4.3.1.4.3	Tensile Test.....	C-5
C.4.3.1.4.4	Dynamic Tear Test.....	C-5
C.4.3.1.4.5	Charpy Impact Transition Curves.....	C-5
C.4.3.1.4.6	Macroetch Specimen.....	C-5
C.4.3.2	First Article Inspection Report.....	C-5
C.4.4	Conformance Inspection.....	C-5
C.4.4.1	Lot Definitions.....	C-5

T9074-BD-GIB-010/0300 Rev 2

Paragraph	Title	Page
C.4.4.1.1	Lot for Tension and Impact Tests.....	C-5
C.4.4.1.2	Lot for Examination and Inspections.....	C-5
C.4.4.2	Sampling for Conformance Inspection.....	C-5
C.4.4.2.1	Sampling for Chemical or Spectrographic Analysis.....	C-5
C.4.4.2.2	Sampling for Tensile and Impact Tests.....	C-5
C.4.4.2.2.1	Location, Orientation, and Number of Specimens.....	C-5
C.4.4.2.2.2	Location of Tensile and Impact Specimens.....	C-5
C.4.4.2.3	Multiple Forgings.....	C-6
C.4.4.2.4	Orientation of Tensile and Impact Specimens.....	C-6
C.4.4.2.5	Marking of Test Specimens.....	C-6
C.4.4.2.6	Sampling for Forging Soundness (Internal).....	C-6
C.4.4.2.7	Sampling for Forging Soundness (External).....	C-6
C.4.4.2.8	Macroscopic Examination.....	C-6
C.4.5	Test Procedures.....	C-6
C.4.5.1	Chemical or Spectrographic Analysis.....	C-6
C.4.5.2	Ultrasonic Test.....	C-6
C.4.5.3	Magnetic Particle Inspection.....	C-6
C.5	PACKAGING.....	C-6
C.6	NOTES.....	C-6
C.6.1	Intended Use.....	C-6
C.6.2	Acquisition Requirements.....	C-6
APPENDIX D (23008)	STEEL CASTINGS, ALLOY, HIGH YIELD STRENGTH (HY-80 AND HY-100).....	D-1
D.1	SCOPE.....	D-1
D.1.1	Scope.....	D-1
D.1.2	Classification.....	D-1
D.2	APPLICABLE DOCUMENTS.....	D-1
D.3	REQUIREMENTS.....	D-1
D.3.1	Material.....	D-1
D.3.2	Chemical Composition.....	D-1
D.3.2.1	Chaplets and Chills.....	D-1
D.3.3	Thickness Definition.....	D-1
D.3.4	Tensile Properties.....	D-2
D.3.5	Impact Properties.....	D-3
D.3.6	Additional Conformance Testing.....	D-4
D.3.7	Heat Treatment.....	D-4
D.3.7.1	Simulated Stress Relief.....	D-6
D.3.7.1.1	Verification of Properties.....	D-6
D.3.8	Explosion Testing.....	D-6
D.3.9	Cleaning.....	D-6
D.3.9.1	Chills and Chaplets.....	D-6

Paragraph	Title	Page
D.3.10	Internal and External Soundness.....	D-6
D.3.11	Repair of Defects.....	D-6
D.3.11.1	Prohibited Filler Metals.....	D-6
D.3.11.2	Minor Repairs.....	D-6
D.3.11.3	Nominal and Special Repairs.....	D-7
D.3.12	Dimensions and Tolerances.....	D-7
D.3.13	Marking.....	D-7
D.3.14	Hardness.....	D-7
D.4	VERIFICATION.....	D-7
D.4.1	Responsibility for Inspection.....	D-7
D.4.2	Classification of Inspections.....	D-7
D.4.3	First Article Inspection.....	D-8
D.4.3.1	First Article Samples.....	D-8
D.4.3.1.1	Castings.....	D-8
D.4.3.1.1.1	Capability and Feasibility of Casting Design.....	D-8
D.4.3.1.2	Prolongation or Test Block.....	D-8
D.4.3.1.2.1	For Castings 6 Inches (152 mm) and Greater in Thickness.....	D-8
D.4.3.1.2.2	Prolongation or Test Block Size.....	D-8
D.4.3.1.2.3	Prolongation or Test Block Heat Treatment.....	D-9
D.4.3.1.3	Explosion Test Specimens.....	D-9
D.4.3.2	First Article Examinations and Tests.....	D-9
D.4.3.2.1	Examination.....	D-9
D.4.3.2.2	Test Specimen Location.....	D-9
D.4.3.2.2.1	Test Specimen Location in Sections Greater than 6 Inches Thick.....	D-9
D.4.3.2.3	Chemical Analysis.....	D-9
D.4.3.2.4	Tensile Test.....	D-10
D.4.3.2.5	Charpy V-Notch.....	D-10
D.4.3.2.6	Dynamic Tear.....	D-10
D.4.3.2.7	Transition Test Curve.....	D-10
D.4.3.2.8	Explosion Test.....	D-10
D.4.3.2.9	Hardness Testing.....	D-10
D.4.3.2.10	First Article Inspection Report.....	D-10
D.4.4	Conformance Inspection.....	D-10
D.4.4.1	Lot Definitions.....	D-10
D.4.4.1.1	Lot for Tension and Impact Tests.....	D-10
D.4.4.1.2	Lot for Examination and Inspections.....	D-10
D.4.4.1.3	Lot for Chemical Composition.....	D-10
D.4.4.2	Sampling for Chemical Analysis.....	D-10
D.4.4.3	Sampling for Mechanical Tests.....	D-10
D.4.4.3.1	Sampling for Mechanical Tests Following Simulated Stress Relief.....	D-10

T9074-BD-GIB-010/0300 Rev 2

Paragraph	Title	Page
	D.4.4.3.2 Sampling for Tensile Test.....	D-11
	D.4.4.3.3 Sampling for Charpy V-Notch Tests.....	D-11
	D.4.4.3.4 Sampling for Dynamic Tear Test.....	D-11
	D.4.4.4 Nondestructive Testing.....	D-11
	D.4.4.4.1 Hardness Testing.....	D-11
	D.4.5 Test Procedures.....	D-11
	D.4.5.1 Chemical Analysis.....	D-11
D.5	PACKAGING.....	D-11
D.6	NOTES.....	D-11
	D.6.1 Intended Use.....	D-11
	D.6.2 Acquisition Requirements.....	D-11
	D.6.3 First Article.....	D-12
	D.6.3.1 Approval for Different Grade Material.....	D-12
	D.6.3.2 Receipt Inspection.....	D-12
APPENDIX E (23009)	STEEL FORGINGS, ALLOY, HIGH YIELD STRENGTH (HY-80 AND HY-100).....	E-1
E.1	SCOPE.....	E-1
	E.1.1 Scope.....	E-1
	E.1.2 Classification.....	E-1
E.2	APPLICABLE DOCUMENTS.....	E-1
E.3	REQUIREMENTS.....	E-1
	E.3.1 Forging Process.....	E-1
	E.3.1.1 Forging Ratios.....	E-1
	E.3.1.2 Boring of Forgings.....	E-1
	E.3.1.3 Forging Thickness Definition.....	E-1
	E.3.2 Chemical Composition.....	E-2
	E.3.3 Tensile Properties.....	E-3
	E.3.4 Impact Properties.....	E-3
	E.3.5 Explosion Testing.....	E-4
	E.3.6 Heat Treatment.....	E-4
	E.3.6.1 Simulated Stress Relief.....	E-5
	E.3.6.1.1 Verification of Properties.....	E-5
	E.3.6.2 Prolongations or Test Blocks.....	E-5
	E.3.7 Forging Sketches.....	E-5
	E.3.8 Dimensions and Tolerances.....	E-5
	E.3.9 Soundness.....	E-6
	E.3.9.1 Surface Soundness.....	E-6
	E.3.9.1.1 Repair of Surface Defects.....	E-6
	E.3.9.1.2 Repair of Surface Defects by Welding.....	E-6
	E.3.9.2 Internal Soundness.....	E-6
	E.3.9.2.1 Ultrasonic Soundness Acceptance Criteria.....	E-6

Paragraph	Title	Page
E.3.9.3	Macroscopic Examination.....	E-6
E.3.10	Identification Marking.....	E-6
E.4	VERIFICATION.....	E-6
E.4.1	Responsibility for Inspection.....	E-6
E.4.2	Classification of Inspections.....	E-6
E.4.3	First Article Inspection.....	E-6
E.4.3.1	First Article Samples.....	E-7
E.4.3.1.1	Forgings.....	E-7
E.4.3.1.1.1	First Article Complexity.....	E-7
E.4.3.1.1.1.1	Solid Shapes.....	E-7
E.4.3.1.1.1.2	Hollow Forgings.....	E-7
E.4.3.1.1.1.3	Ring Forgings.....	E-7
E.4.3.1.1.1.4	Other, More Complex Designs.....	E-7
E.4.3.1.2	Test Prolongations.....	E-8
E.4.3.1.2.1	Prolongation or Separately Forged Test Block Sizes.....	E-8
E.4.3.1.3	Explosion Test Specimens.....	E-8
E.4.3.1.4	Test Specimen Location.....	E-8
E.4.3.1.4.1	Chemical Analysis.....	E-8
E.4.3.1.4.2	Tensile Test.....	E-8
E.4.3.1.4.3	Dynamic Tear.....	E-8
E.4.3.1.4.4	Charpy V-Notch.....	E-9
E.4.3.1.4.5	Charpy Impact Transition Curves.....	E-9
E.4.3.1.4.6	Macroscopic Examination.....	E-9
E.4.3.2	First Article Inspection Report.....	E-9
E.4.4	Conformance Inspection.....	E-9
E.4.4.1	Lot Size.....	E-9
E.4.4.1.1	Lot Size for Tension and Impact Tests.....	E-9
E.4.4.1.2	Lot Size for Examination and Inspection.....	E-9
E.4.4.1.3	Lot Size for Chemical Analysis.....	E-9
E.4.4.2	Sampling for Chemical Analysis.....	E-9
E.4.4.3	Sampling for Mechanical Properties.....	E-9
E.4.4.3.1	Location, Orientation, and Number of Specimens.....	E-9
E.4.4.3.2	Location of Mechanical Test Specimens.....	E-9
E.4.4.3.2.1	Distance of Tensile and Impact Specimens from the Nearest Heat Treated Surface.....	E-9
E.4.4.3.2.2	Distance of Tensile and Impact Specimens from the Second Nearest Heat Treated Surface.....	E-9
E.4.4.3.2.3	Distance of Tensile and Impact Specimens from the End of the Forging.....	E-10
E.4.4.3.2.4	Sampling for Mechanical Properties Following Simulated Stress Relief.....	E-10
E.4.4.3.2.5	Multiple Forgings.....	E-10
E.4.4.3.3	Orientation of Test Specimens.....	E-10
E.4.4.3.3.1	Orientation of Longitudinal Tensile Specimens.....	E-10

T9074-BD-GIB-010/0300 Rev 2

Paragraph	Title	Page
E.4.4.3.3.2	Orientation of Transverse Tensile Specimens.....	E-10
E.4.4.3.3.3	Orientation of Impact Specimens.....	E-10
E.4.4.4	Sampling for Forging Soundness (Internal).....	E-10
E.4.4.5	Sampling for Forging Soundness (External).....	E-11
E.4.4.6	Macroscopic Examination.....	E-11
E.4.4.7	Visual and Dimensional Examination.....	E-11
E.4.5	Test Procedures.....	E-11
E.4.5.1	Chemical or Spectrographic Analysis.....	E-11
E.4.5.2	Ultrasonic Test.....	E-11
E.4.5.3	Magnetic Particle Inspection.....	E-11
E.5	PACKAGING.....	E-11
E.6	NOTES.....	E-11
E.6.1	Intended Use.....	E-11
E.6.2	Acquisition Requirements.....	E-11
E.6.3	First Article.....	E-12
E.6.3.1	First Article Approval.....	E-12
E.6.4	Receipt Inspection.....	E-12
APPENDIX F (24371)	STEEL PLATE, STRUCTURAL, HIGH YIELD STRENGTH (HY-130).....	F-1
F.1	SCOPE.....	F-1
F.1.1	Scope.....	F-1
F.1.2	Classification.....	F-1
F.2	APPLICABLE DOCUMENTS.....	F-1
F.3	REQUIREMENTS.....	F-1
F.3.1	Materials.....	F-1
F.3.2	Ingots and Slabs.....	F-1
F.3.3	Heat Treatment.....	F-1
F.3.4	Chemical Composition.....	F-2
F.3.5	Tensile Properties.....	F-3
F.3.6	Impact Tests.....	F-3
F.3.6.1	Impact Properties.....	F-4
F.3.7	Stress Relief.....	F-4
F.3.8	Visual Requirements.....	F-4
F.3.8.1	Surface Quality.....	F-4
F.3.8.2	Weld Repair of Mill Defects Prior to Heat Treatment.....	F-4
F.3.8.3	Weld Repairs After Heat Treatment.....	F-5
F.3.8.4	Edge Defects.....	F-5
F.3.9	Internal Soundness and Thickness.....	F-5
F.3.9.1	Classification and Recording of Internal Soundness.....	F-5
F.3.10	Applicable Fabrication Document.....	F-5
F.3.11	Dimensional Tolerances.....	F-5

Paragraph	Title	Page
F.3.11.1	Thickness, Weight, and Gauge	F-5
F.3.11.2	Flatness	F-5
F.3.11.3	Camber	F-10
F.3.11.4	Size Tolerances	F-10
F.3.12	Explosion Test	F-12
F.3.13	Cleaning and Preservation of Plate Surfaces	F-12
F.3.14	Marking	F-12
F.4	VERIFICATION	F-12
F.4.1	Responsibility for Inspection	F-12
F.4.2	Classification of Inspections	F-12
F.4.3	First Article Inspection	F-12
F.4.4	Conformance Inspection	F-13
F.4.4.1	Lot Definitions	F-13
F.4.4.1.1	Lot for Tension Tests	F-13
F.4.4.1.2	Lot for Impact Tests	F-13
F.4.4.1.3	Lot for Examination and Inspection	F-13
F.4.4.2	Sampling for Conformance Inspection	F-13
F.4.4.2.1	Location of Test Specimens in Plate	F-13
F.4.4.2.2	Sampling for Examination and Inspection	F-13
F.4.4.2.3	Sampling for Chemical and Spectrographic Analysis	F-13
F.4.4.2.4	Sampling for Tensile Test	F-13
F.4.4.2.5	Sampling for Impact Test	F-13
F.4.4.2.5.1	Charpy V-Notch Testing	F-13
F.4.4.2.5.2	Dynamic Tear Testing	F-14
F.4.4.2.6	Thermal Buffer Pad Requirements	F-14
F.4.4.2.7	Marking of Test Specimens	F-14
F.4.5	Visual Examination	F-14
F.4.6	Test Procedures	F-14
F.4.6.1	Chemical or Spectrographic Analysis	F-14
F.4.6.1.1	Continuous Cast Slabs	F-14
F.4.6.2	Tensile Tests	F-14
F.4.6.3	Impact Tests	F-14
F.4.6.3.1	Charpy V-Notch Impact Test	F-14
F.4.6.3.2	Dynamic Tear Impact Test	F-14
F.4.6.4	Explosion Test	F-14
F.4.6.5	Gauging and Ultrasonic Soundness Test	F-14
F.5	PACKAGING	F-14
F.6	NOTES	F-15
F.6.1	Intended Use	F-15
F.6.2	Acquisition Requirements	F-15

T9074-BD-GIB-010/0300 Rev 2

Paragraph	Title	Page
F.6.3	First Article.....	F-15
F.6.4	Receipt Inspection.....	F-15
APPENDIX G (21952) STEEL (HY-80 AND HY-100) BARS, ALLOY		G-1
G.1	SCOPE.....	G-1
G.1.1	Scope.....	G-1
G.1.2	Classification.....	G-1
G.1.2.1	Grades.....	G-1
G.1.2.2	Types.....	G-1
G.2	APPLICABLE DOCUMENTS.....	G-1
G.3	REQUIREMENTS.....	G-1
G.3.1	Material.....	G-1
G.3.2	Chemical Composition.....	G-2
G.3.3	Tensile Properties.....	G-3
G.3.4	Impact Properties.....	G-3
G.3.5	Heat Treatment.....	G-3
G.3.5.1	Simulated Stress Relief.....	G-4
G.3.6	Surface Quality.....	G-4
G.3.7	Dimensions and Tolerances.....	G-4
G.3.8	Identification Marking.....	G-4
G.3.8.1	Type A Bars.....	G-4
G.3.8.2	Type B Bars.....	G-4
G.3.9	Descaling and Cleaning.....	G-4
G.3.10	Macrostructure.....	G-5
G.3.11	Repair by Welding.....	G-5
G.3.12	Explosion Testing.....	G-5
G.4	VERIFICATION.....	G-5
G.4.1	Responsibility for Inspection.....	G-5
G.4.2	Classification of Inspections.....	G-5
G.4.3	First Article Inspection.....	G-5
G.4.3.1	Sampling for First Article Inspection.....	G-5
G.4.4	Conformance Inspection.....	G-5
G.4.4.1	Lot Definitions.....	G-5
G.4.4.1.1	Lot for Chemical Composition.....	G-5
G.4.4.1.2	Lot for Macroetch Tests.....	G-5
G.4.4.1.3	Lot for Tension and Impact Tests.....	G-5
G.4.4.1.4	Lot for Dimensional and Surface Examination.....	G-6
G.4.4.2	Sampling for Conformance Inspection.....	G-6
G.4.4.2.1	Sampling for Chemical or Spectrographic Analysis.....	G-6
G.4.4.2.2	Sampling for Macroetch Test.....	G-6
G.4.4.2.2.1	Partial Heats.....	G-6

Paragraph	Title	Page
G.4.4.2.3	Sampling for Mechanical Tests.....	G-6
G.4.4.2.3.1	Tension Test Specimens.....	G-6
G.4.4.2.3.2	Charpy V-Notch Test Specimen.....	G-6
G.4.4.2.3.3	Dynamic Tear Test Specimen.....	G-6
G.4.4.2.3.4	Marking of Test Specimens.....	G-7
G.4.4.2.4	Sampling for Mechanical Properties Following Simulated Stress Relief.....	G-7
G.4.5	Examination.....	G-7
G.4.5.1	Dimensional Examination.....	G-7
G.4.5.2	Visual Examination Prior to Packaging.....	G-7
G.4.5.3	Nondestructive Examination.....	G-7
G.4.5.3.1	Ultrasonic Examination.....	G-7
G.4.6	Methods of Inspection.....	G-7
G.4.6.1	Chemical or Spectrographic Analysis.....	G-7
G.4.6.2	Charpy V-Notch Impact Test.....	G-7
G.4.6.3	Macrostructure.....	G-7
G.4.7	Macroetch Tests.....	G-7
G.5	PACKAGING.....	G-7
G.6	NOTES.....	G-7
G.6.1	Intended Use.....	G-7
G.6.2	Acquisition Requirements.....	G-7
APPENDIX H (22664) STEEL, STRUCTURAL SHAPES ALLOY, HIGH YIELD STRENGTH (HY-80 AND HY-100)		H-1
H.1	SCOPE.....	H-1
H.1.1	Scope.....	H-1
H.2	APPLICABLE DOCUMENTS.....	H-1
H.3	REQUIREMENTS.....	H-1
H.3.1	Chemical Composition.....	H-1
H.3.2	Tensile Properties.....	H-2
H.3.3	Impact Properties.....	H-2
H.3.4	Heat Treatment.....	H-2
H.3.5	Surface Quality.....	H-3
H.3.5.1	Surface Conditioning.....	H-3
H.3.5.2	Weld Repairs.....	H-3
H.3.5.3	Macrostructure.....	H-3
H.3.5.4	Billets.....	H-3
H.3.6	Dimensions and Tolerances.....	H-3
H.3.7	Surface Treatment.....	H-3
H.3.8	Internal Soundness.....	H-3
H.3.9	Identification Marking.....	H-3
H.3.10	Workmanship.....	H-3
H.3.11	Explosion Testing.....	H-3

T9074-BD-GIB-010/0300 Rev 2

Paragraph	Title	Page
H.4	VERIFICATION.....	H-4
H.4.1	Responsibility for Inspection.....	H-4
H.4.2	Classification of Inspections.....	H-4
H.4.3	First Article Inspection.....	H-4
H.4.3.1	Sampling for First Article Inspection.....	H-4
H.4.4	Conformance Inspection.....	H-4
H.4.4.1	Lot Definitions.....	H-4
H.4.4.1.1	Lot for Chemical Composition.....	H-4
H.4.4.1.2	Lot Size for Mechanical Tests.....	H-4
H.4.4.1.3	Lot Size for Visual and Dimensional Examination and Ultrasonic Inspection.....	H-4
H.4.4.2	Sampling for Conformance Testing.....	H-4
H.4.4.2.1	Sampling for Chemical or Spectrographic Analysis.....	H-4
H.4.4.2.2	Sampling for Mechanical Tests.....	H-4
H.4.4.2.2.1	Form and Dimensions of Mechanical Test Specimens.....	H-5
H.4.5	First Article Inspection.....	H-5
H.4.6	Conformance Inspection.....	H-5
H.4.7	Visual and Dimensional Examination.....	H-5
H.4.8	Ultrasonic Inspection.....	H-5
H.4.9	Methods of Inspection.....	H-5
H.4.9.1	Chemical or Spectrographic Analysis.....	H-5
H.4.9.2	Tension Test.....	H-5
H.4.9.3	Charpy V-Notch Impact Test.....	H-5
H.4.9.4	Macroetch Test.....	H-5
H.4.10	Reheat Treatment Provisions.....	H-5
H.4.11	Heat Treatment Test Report.....	H-5
H.5	PACKAGING.....	H-5
H.6	NOTES.....	H-5
H.6.1	Intended Use.....	H-5
H.6.2	Acquisition Requirements.....	H-5
APPENDIX I (24451) STEEL HEAT TREATED HEADS, ALLOY STRUCTURAL, HIGH YIELD STRENGTH (HY-80 AND HY-100).....		I-1
I.1	SCOPE.....	I-1
I.1.1	Scope.....	I-1
I.2	APPLICABLE DOCUMENTS.....	I-1
I.3	REQUIREMENTS.....	I-1
I.3.1	Material.....	I-1
I.3.2	Two-Piece Heads (Weldments).....	I-1
I.3.3	Mechanical Properties.....	I-1
I.3.3.1	Two-Piece Heads.....	I-1
I.3.4	Resizing.....	I-1

Paragraph	Title	Page
I.3.4.1	Resizing by Warm Forming	I-1
I.3.5	Heat Treatment.....	I-1
I.3.6	Surface Quality.....	I-2
I.3.6.1	Weld Repair of Mill Defects After Heat Treatment	I-2
I.3.6.2	Weld Repair of Mill Defects Prior to Heat Treatment.....	I-2
I.3.7	Form and Dimensions.....	I-2
I.3.8	Tolerances.....	I-3
I.3.9	Ultrasonic Inspection (Base Material for Soundness).....	I-3
I.3.10	Cleaning and Preservation.....	I-3
I.3.11	Explosion Test.....	I-3
I.4	VERIFICATION.....	I-3
I.4.1	Responsibility for Inspection.....	I-3
I.4.2	Classification of Inspections.....	I-3
I.4.3	First Article Inspection.....	I-3
I.4.3.1	First Article Sample.....	I-3
I.4.3.2	Heads, Base Metal Tests.....	I-3
I.4.3.3	Weld Metal Tests.....	I-3
I.4.4	Conformance Inspection.....	I-3
I.4.4.1	Sampling for Conformance Inspection.....	I-3
I.4.4.1.1	Lot.....	I-3
I.4.4.1.2	Sampling for Chemical or Spectrographic Analysis.....	I-3
I.4.4.1.3	Sampling for Tension and Hardness Tests.....	I-3
I.4.4.1.3.1	One-Piece Heads Up to 48 Inches (1219 mm), Inclusive Outside Diameter (od).....	I-3
I.4.4.1.3.2	One-Piece Heads Over 48 Inches (1219 mm) od.....	I-4
I.4.4.1.3.3	Two-Piece Heads.....	I-4
I.4.4.1.4	Sampling for Impact Tests.....	I-4
I.4.4.1.4.1	One-Piece Heads Up to 48 Inches (1219 mm) od, Inclusive.....	I-4
I.4.4.1.4.2	One-Piece Heads Over 48 Inches (1219 mm) od.....	I-4
I.4.4.1.4.3	Two-Piece Heads.....	I-4
I.4.4.2	Mechanical Property Test Locations.....	I-4
I.4.4.2.1	Heads Up to 6 Inches (152 mm) Thick, Inclusive.....	I-4
I.4.4.2.2	Heads Over 6 Inches (152 mm) Thick.....	I-4
I.4.4.2.3	Weldment Test Specimens.....	I-4
I.4.4.2.4	Buffer Plate Requirements.....	I-4
I.4.4.2.5	Location of Test Specimens in the Head.....	I-4
I.4.4.2.6	Marking of Test Specimens.....	I-5
I.4.5	Examination.....	I-5
I.4.5.1	Visual and Dimensional Examination.....	I-5
I.4.5.2	Radiography and Magnetic Particle Inspection of Two-Piece Head Weldments.....	I-5
I.4.6	Methods of Inspection.....	I-5

T9074-BD-GIB-010/0300 Rev 2

Paragraph	Title	Page
I.4.6.1	Chemical Analysis.....	I-5
I.4.6.2	Tensile Test.....	I-5
I.4.6.2.1	Tensile Tests, Two-Piece Head.....	I-5
I.4.6.3	Impact Tests.....	I-5
I.4.6.4	Nondestructive Inspections.....	I-5
I.4.6.5	Explosion Tests of Two-Piece Head Weldments.....	I-5
I.4.7	Retests.....	I-5
I.4.7.1	Impact Retest.....	I-5
I.5	PACKAGING.....	I-5
I.6	NOTES.....	I-5
I.6.1	Intended Use.....	I-5
I.6.2	Acquisition Requirements.....	I-5
APPENDIX J ULTRASONIC THICKNESS TESTING REQUIREMENTS AND EVALUATION.....		J-1
J.1	SCOPE.....	J-1
J.1.1	Scope.....	J-1
J.2	APPLICABLE DOCUMENTS.....	J-1
J.3	REQUIREMENTS.....	J-1
J.3.1	General.....	J-1
J.3.2	Surface Preparation.....	J-1
J.3.3	Extent of Test.....	J-1
J.3.3.1	Ultrasonic Thickness Measurements.....	J-1
J.3.4	Couplant.....	J-1
J.3.5	Reference Base Designation.....	J-1
J.4	TECHNIQUES.....	J-1
J.4.1	Plate Ultrasonic Thickness Testing.....	J-1
J.4.1.1	Calibration.....	J-1
J.4.1.2	Testing Pattern.....	J-1
J.4.1.2.1	Expanded Search.....	J-1
J.4.1.3	Reporting.....	J-1
J.4.2	Acceptance Criteria.....	J-1
J.4.2.1	Thickness Testing.....	J-1
J.4.3	Reporting.....	J-1
J.5	PACKAGING.....	J-2
J.6	NOTES.....	J-2
APPENDIX K COATINGS.....		K-1
K.1	SCOPE.....	K-1
K.1.1	Scope.....	K-1
K.1.2	Storage.....	K-1
K.2	APPLICABLE DOCUMENTS.....	K-1
K.3	REQUIREMENTS.....	K-1

Paragraph	Title	Page
K.3.1	Coating.....	K-1
K.3.1.1	HSLA-80.....	K-1
K.3.1.2	HSLA-100.....	K-1
K.3.1.3	HY-80.....	K-1
K.3.1.4	HY-100.....	K-1
K.3.1.5	HY-130.....	K-1
K.3.1.5.1	Color Cards.....	K-1
K.4	PROCEDURES.....	K-2
K.4.1	Descaling and Cleaning.....	K-2
K.4.1.1	Abrasive Blast Cleaning.....	K-2
K.4.1.2	Acid Pickling.....	K-2
K.5	PACKAGING.....	K-2
K.6	NOTES.....	K-2
K.6.1	Intended Use.....	K-2
K.6.2	Acquisition Requirements.....	K-2
APPENDIX L (2149) STANDARD PROCEDURES FOR EXPLOSION TESTING FERROUS AND NON-FERROUS METALLIC MATERIALS AND WELDMENTS.....		L-1
L.1	SCOPE.....	L-1
L.1.1	Scope.....	L-1
L.1.2	Test Methods.....	L-1
L.1.3	Approval Authority.....	L-1
L.2	APPLICABLE DOCUMENTS.....	L-1
L.3	DEFINITIONS.....	L-1
L.3.1	General.....	L-1
L.3.1.1	All-Weld-Metal Test Specimen.....	L-1
L.3.1.2	Bulge Area.....	L-1
L.3.1.3	Compression Side.....	L-1
L.3.1.4	Crack Starter Bead.....	L-1
L.3.1.5	Explosion Test.....	L-1
L.3.1.6	Explosion Bulge Test.....	L-1
L.3.1.7	Explosion Crack Starter Test.....	L-1
L.3.1.8	Explosion Tear Test (ETT).....	L-1
L.3.1.9	Explosive.....	L-1
L.3.1.10	Explosive Standoff Distance.....	L-1
L.3.1.11	Finished Weld.....	L-1
L.3.1.12	Heat Soak.....	L-1
L.3.1.13	Hold-Down Area.....	L-1
L.3.1.14	Prolongation.....	L-2
L.3.1.15	Reduction in Thickness (Percent).....	L-2
L.3.1.16	Tension Side.....	L-2

T9074-BD-GIB-010/0300 Rev 2

Paragraph	Title	Page
L.4	GENERAL REQUIREMENTS.....	L-2
L.4.1	Material Qualification.....	L-2
L.5	DETAILED REQUIREMENTS.....	L-2
L.5.1	Mechanical Test Samples.....	L-2
L.5.2	Explosion Crack Starter Samples.....	L-2
L.5.3	Explosion Bulge Specimens.....	L-2
L.5.4	Explosion Tear Test.....	L-2
L.6	QUALIFICATION CONDITION OF MATERIAL.....	L-2
L.6.1	Base Metal Product Forms.....	L-2
L.6.1.1	Rolled Plate.....	L-2
L.6.1.2	Castings.....	L-2
L.6.1.3	Forgings and Shapes.....	L-2
L.6.1.4	Maximum 1-Inch Thickness Material.....	L-3
L.6.2	Filler Metals.....	L-3
L.6.3	Welding Procedure.....	L-3
L.7	PREPARATION AND WELDING OF EXPLOSION TEST WELDMENTS WITH AND WITHOUT MECHANICAL PROLONGATION.....	L-3
L.7.1	Preparation of Base Metal for Welding.....	L-3
L.7.2	Welding of Samples.....	L-3
L.7.2.1	Base Metal.....	L-3
L.7.2.2	Electrodes and Welding Procedures.....	L-3
L.7.3	Nondestructive Evaluation of Test Weldments.....	L-3
L.7.3.1	Visual Inspection.....	L-3
L.7.3.2	Radiographic Inspection (RT).....	L-3
L.7.3.3	Magnetic Particle Inspection (MT).....	L-3
L.8	PREPARATION OF TEST ASSEMBLIES FOR EXPLOSION TESTING.....	L-3
L.8.1	Crack Starter Specimen Preparation.....	L-3
L.8.1.1	Base Metal Evaluations.....	L-3
L.8.1.2	Weld Metal and Weld Procedure Evaluations.....	L-4
L.8.1.3	Crack Starter Bead Application.....	L-4
L.8.1.4	Notching the Hardex N or Equivalent Weld Bead.....	L-4
L.8.2	Explosion Bulge Preparation.....	L-4
L.8.3	Explosion Tear Test Specimen.....	L-4
L.8.4	Grinding for Die Fit and Drilling Thermocouple Holes.....	L-4
L.9	MECHANICAL AND EXPLOSION TESTING.....	L-4
L.9.1	Mechanical Test Assembly Requirements.....	L-4
L.9.1.1	Tensile Test Specimens.....	L-4
L.9.1.2	Charpy V-Notch Specimens.....	L-4
L.9.1.3	Dynamic Tear Test Specimens.....	L-5
L.9.1.4	Bend Specimens.....	L-5

Paragraph	Title	Page
L.9.2	Explosion Test Assembly Requirements.....	L-5
L.9.2.1	Explosion Crack Starter Testing.....	L-5
L.9.2.2	Explosion Bulge Testing.....	L-5
L.9.2.2.1	No Tests.....	L-5
L.9.3	Explosion Test Procedure.....	L-5
L.9.3.1	Refrigeration of Test Specimens.....	L-5
L.9.3.1.1	Establishment of Test Assembly Cooling Requirements.....	L-6
L.9.3.1.2	Cooling Procedure.....	L-6
L.9.3.2	Setting the Explosion Test Specimen and Detonation of Explosive Charge.....	L-6
L.9.3.3	Explosive Types.....	L-6
L.9.3.4	Explosive Charge Weight Selection.....	L-6
L.9.3.5	Crack Description.....	L-7
L.9.3.5.1	Reduction in Thickness Measuring Devices.....	L-7
L.9.3.6	Successive Explosive Loadings.....	L-7
L.10	NOTES.....	L-7
L.10.1	Intended Use.....	L-7
L.10.2	Consideration of Data Requirements.....	L-7
L.10.3	Other Crack Starter Geometries.....	L-7
L.10.4	Subject Term (Key Word) Listing.....	L-7
L.11	TEST REPORT TECHNICAL CONTENT REQUIREMENTS.....	L-8
L.11.1	Scope.....	L-8
L.11.2	Test Reports.....	L-8
APPENDIX M	SUPPLEMENTAL TECHNICAL REQUIREMENTS TO ISO 9001:2000.....	M-1
M.1	SCOPE.....	M-1
M.1.1	Scope.....	M-1
M.2	APPLICABLE DOCUMENTS.....	M-1
M.3	REQUIREMENTS.....	M-1
M.3.1	Supplemental Requirements.....	M-1
M.3.1.1	Organization Quality System.....	M-1
M.3.1.2	Coordinated Government/Organization Actions and Use of Organization Inspection Facilities.....	M-1
M.3.1.3	Sample Inspection.....	M-1
M.3.1.4	Interpretation of Limits.....	M-2
M.3.1.5	Electronic Signatures.....	M-2

T9074-BD-GIB-010/0300 Rev 2

THIS PAGE INTENTIONALLY LEFT BLANK

LIST OF ILLUSTRATIONS

Figure	Title	Page
Figure 3-1.	Heat Treatment Procedure Information.....	3-3
Figure 3-2.	Information to be Documented on the Heat Treatment Record.....	3-4
Figure A-1.	First Article Inspection Testing (Plate <3 Inches Thick).....	A-20
Figure A-2.	First Article Inspection Testing (Plate ≥3 Inches Thick).....	A-21
Figure A-3.	Method of Locating Test Specimens for Conformance Inspection of Plates as Rolled from Ingots or Slabs with the Final Direction of Rolling Parallel to the Longitudinal Axis of the Ingot.....	A-22
Figure A-4.	Method of Locating Test Specimens for Conformance Inspection of Plates as Rolled from Ingots or Slabs with the Final Direction of Rolling Parallel to the Transverse Axis of the Ingot.....	A-23
Figure A-5.	Sample Plate Ultrasonic Soundness Report.....	A-24
Figure B-1.	First Article Inspection Testing (Plate <3 Inches Thick).....	B-19
Figure B-2.	First Article Inspection Testing (Plate ≥3 Inches Thick).....	B-20
Figure B-3.	Method of Locating Test Specimens for Conformance Inspection for Plates as Rolled Directly from Ingots or Slabs with the Final Direction of Rolling Parallel to the Longitudinal Axis of the Ingot.....	B-21
Figure B-4.	Method of Locating Test Specimens for Conformance Inspection for Plates as Rolled Directly from Ingots or Slabs with the Final Direction of Rolling Parallel to the Transverse Axis of the Ingot.....	B-22
Figure C-1.	Typical Schematic Diagram of Test Specimen Location for 6-Inch Thick Forgings, “Rectangular Like” in Cross-Section.....	C-8
Figure C-2.	Typical Schematic Diagram of Test Specimen Location for 12-Inch Thick Forgings of Solid Circular Cross-Section.....	C-9
Figure C-3.	Typical Schematic Diagram of Test Specimen Location for 6-Inch Thick Forgings of Hollow Circular Cross-Section.....	C-10
Figure D-1.	Sample First Article Casting.....	D-13
Figure D-2.	Schematic Diagram of Test Specimen Location for Castings Greater than 6 Inches in Thickness.....	D-15
Figure E-1.	Typical Schematic Diagram of Test Specimen Location for a 12-Inch Thick HY-100 Forging “Rectangular-Like” in Cross-Section.....	E-13
Figure E-2.	Typical Schematic Diagram of Test Specimen Location for a 12-Inch Diameter HY-100 Forging of Solid Circular Cross-Section.....	E-14
Figure E-3.	Typical Schematic Diagram of Test Specimen Location for an 8-Inch Thick HY-80 Forging of Bored Circular Cross-Section.....	E-15
Figure F-1.	First Article Inspection Testing (Plate <3 Inches Thick).....	F-16
Figure F-2.	First Article Inspection Testing (Plate ≥3 Inches Thick).....	F-17
Figure F-3.	Method of Locating Test Specimens for Plates as Rolled Directly from Ingots or Slabs with the Final Direction of Rolling Parallel to the Longitudinal Axis of the Ingot.....	F-18
Figure F-4.	Method of Locating Test Specimens for Plates as Rolled Directly from Ingots or Slabs with the Final Direction of Rolling Parallel to the Transverse Axis of the Ingot.....	F-19
Figure G-1.	Typical Schematic Diagram of Transverse Test Specimen Location on an 8-Inch Diameter Bar.....	G-9
Figure H-1.	Dimensional Tolerances and Nomenclature for Structural Tee Extrusions.....	H-7
Figure H-2.	Location of Mechanical Test Coupons for Structural Tee.....	H-8
Figure I-1.	One-Piece Head Up to 48 Inches (1219 mm) od, Inclusive – Test Layout.....	I-7
Figure I-2.	One-Piece Head Over 48 Inches (1219 mm) od – Test Layout.....	I-8

T9074-BD-GIB-010/0300 Rev 2

Figure	Title	Page
Figure I-3.	Two-Piece Head – Test Layout.....	I-9
Figure I-4.	Location and Orientation of Weld Metal Charpy and Dynamic Tear Impact Specimens on Two-Piece Heads. I-10	I-10
Figure J-1.	Sample Plate Gauging Report (Micrometer and Ultrasonic).....	J-3
Figure L-1.	Explosion Test Specimen Configuration.	L-9
Figure L-2.	Diagram of a Typical Mechanical Removal Orientation.	L-10
Figure L-3.	Prolongation Mechanical Property Specimen Layout for Preproduction Qualification Testing.....	L-11
Figure L-4.	Explosion Test Plate Preparation.	L-12
Figure L-5.	Explosion Tear Test Weldment.	L-13
Figure L-6.	Typical Configuration for Explosion Test Weldments.	L-14
Figure L-7.	Crack Starter Bead Configuration – Base Metal Evaluation Without a Weld Joint.....	L-15
Figure L-8.	Crack Starter Bead Configuration – Base Metal Evaluation Incorporating a Weld Joint.	L-15
Figure L-9.	Crack Starter Bead Configuration – Weld Metal and Weld Procedure Evaluation.	L-16
Figure L-10.	Explosion Test Measurements.	L-17
Figure L-11.	Explosion Test Configuration.	L-18
Figure L-12.	Typical Fracture Sketch of Explosion Test Weldment.	L-19
Figure L-13.	Sample Explosion Testing Record.....	L-20

LIST OF TABLES

Table	Title	Page
Table A-1.	Chemical Composition (Weight Percent).....	A-2
Table A-2.	Tensile Property Requirements.	A-3
Table A-3.	Impact Requirements, Charpy V-Notch, Transverse.....	A-4
Table A-4.	Allowable Variation in Weight and Gauge for Plates Specified on a Weight Basis (Applicable to Single Plates)....	A-7
Table A-5.	Thickness Tolerances in Inches and Millimeters (average) Over Ordered Thickness for Single Plate 2 Inches (51 mm) and Under in Thickness.....	A-8
Table A-6.	Thickness Tolerances in Inches (mm) (Average) Over Ordered Thickness for a Single Plate Over 2 Inches (51 mm) Thick When Ordered to Thickness in Inches (mm).	A-9
Table A-7.	Flatness Tolerances for Plates Ordered on a lb/ft ² [kg/m ²] or Inch (mm) Basis.	A-11
Table A-8.	Camber Tolerances for Plates Ordered on a lb/ft ² [kg/m ²] or Inch (mm) Basis.	A-12
Table A-9.	Width and Length Tolerances for Sheared Plates 1 Inch (25 mm) Thick or Less.	A-13
Table A-10.	Width and Length Tolerances for Gas-Cut Rectangular Plates.	A-14
Table A-11.	First Article and Conformance Inspection Requirements.....	A-16
Table B-1.	Chemical Composition (Weight Percent).....	B-2
Table B-2.	Tensile Property Requirements.....	B-3
Table B-3.	Impact Test Application.	B-3
Table B-4.	Impact Test Requirements for First Article and Conformance Testing.....	B-4
Table B-5.	Minimum Tempering and Stress Relief Temperatures.	B-5
Table B-6.	Thickness Tolerances in Inches and Millimeters (Average) Over Ordered Thickness for Single Plate 2 Inches (51mm) and Under in Thickness.	B-8
Table B-7.	Thickness Tolerances in Inches (mm) (Average) Over Ordered Thickness for a Single Plate over 2 Inches (51mm) Thick when Ordered to Thickness in Inches (mm).....	B-9
Table B-8.	Allowable Variation in Weight and Gauge for Plates Specified on a Weight Basis (Applicable to Single Plates)....	B-10
Table B-9.	Flatness Tolerances for Plates Ordered on a lb/ft ² [kg/m ²] or Inch (mm) Basis.	B-11
Table B-10.	Camber Tolerances for Plates Ordered on a lb/ft ² [kg/m ²] or Inch (mm) Basis.....	B-12
Table B-11.	Width and Length Tolerances for Sheared Plates 1 Inch (25 mm) Thick or Less.	B-13
Table B-12.	Width and Length Tolerances for Gas-Cut Rectangular Plates.	B-14
Table B-13.	First Article and Conformance Inspection Requirements.....	B-15
Table C-1.	Chemical Composition (Weight Percent).....	C-1
Table C-2.	Tensile Properties – Longitudinal and Transverse.....	C-2
Table C-3.	First Article and Conformance Requirements.	C-4
Table D-1.	Chemical Composition (Weight Percent).....	D-2
Table D-2.	Tensile Property Requirements.	D-3
Table D-3.	Impact Property Requirements.....	D-4
Table D-4.	Hydrogen Soak Time.....	D-6
Table D-5.	First Article and Conformance Inspection Requirements.....	D-8
Table D-6.	Dimensions of Test Blocks.....	D-9

T9074-BD-GIB-010/0300 Rev 2

Table	Title	Page
Table E-1.	Chemical Composition (Weight Percent).....	E-2
Table E-2.	Tensile Property Requirements.....	E-3
Table E-3.	Impact Property Requirements.....	E-3
Table E-4.	First Article and Conformance Inspection Requirements.....	E-7
Table F-1.	Chemical Composition (Weight Percent).....	F-2
Table F-2.	Tensile Property Requirements (Transverse).....	F-3
Table F-3.	Impact Test Application.....	F-3
Table F-4.	Impact Property Requirements (Transverse).....	F-4
Table F-5.	Thickness Tolerances in Inches and Millimeters (Average) Over Ordered Thickness for Single Plate 2 Inches (51 mm) and Under in Thickness.....	F-6
Table F-6.	Thickness Tolerances in Inches (mm) (Average) Over Ordered Thickness for a Single Plate Over 2 Inches (51 mm) Thick When Ordered to Thickness in Inches (mm).....	F-7
Table F-7.	Allowable Variation in Weight and Gauge for Plates Specified on a Weight Basis (Applicable to Single Plates).....	F-8
Table F-8.	Flatness Tolerances for Plates Ordered on a lb/ft ² [kg/m ²] or Inch (mm) Basis.....	F-9
Table F-9.	Camber Tolerances for Plates Ordered on a lb/ft ² [kg/m ²] or Inch (mm) Basis.....	F-10
Table F-10.	Width and Length Tolerances for Sheared Plates 1 Inch (25 mm) Thick or Less.....	F-11
Table F-11.	Width and Length Tolerances for Gas-Cut Rectangular Plates.....	F-12
Table F-12.	First Article and Conformance Inspection Requirements.....	F-13
Table G-1.	Chemical Composition (Weight Percent).....	G-2
Table G-2.	Tensile Property Requirements.....	G-3
Table G-3.	Impact Property Requirements.....	G-3
Table G-4.	Minimum Tempering and Stress Relief Temperatures.....	G-4
Table G-5.	Sampling for Macroetch Tests.....	G-6
Table H-1.	Chemical Composition (Weight Percent).....	H-1
Table H-2.	Tensile Property Requirements.....	H-2
Table H-3.	Impact Requirements, Charpy V-Notch.....	H-2
Table I-1.	Minimum Tempering Temperature.....	I-2
Table L-1.	Explosion Test Acceptance Criteria.....	L-5

FOREWORD

This specification covers the general requirements, quality assurance provisions, test procedures, and instructions for preparation for delivery for high-strength steel plate, shapes, bars, castings, forgings, and other products. This document is organized as follows:

List of Changes

Chapter 1, Scope

Chapter 2, Applicable Documents

Chapter 3, Requirements

Chapter 4, Verification

Chapter 5, Packaging

Chapter 6, Notes

Appendix A (24645), Steel Plate, Sheet, or Coil, Age-Hardening Alloy, Structural, High Yield Strength (HSLA-80 and HSLA-100)

Appendix B (16216), Steel Plate, Alloy, Structural, High Yield Strength (HY-80 and HY-100)

Appendix C (24512), Steel Forgings, Alloy, Structural, High Yield Strength (HY-130)

Appendix D (23008), Steel Castings, Alloy, High Yield Strength (HY-80 and HY-100)

Appendix E (23009), Steel Forgings, Alloy, High Yield Strength (HY-80 and HY-100)

Appendix F (24371), Steel Plate, Structural, High Yield Strength (HY-130)

Appendix G (21952), Steel (HY-80 and HY-100) Bars, Alloy

Appendix H (22664), Steel, Structural Shapes Alloy, High Yield Strength (HY-80 and HY-100)

Appendix I (24451), Steel Heat Treated Heads, Alloy Structural, High Yield Strength (HY-80 and HY-100)

Appendix J, Ultrasonic Thickness Testing Requirements and Evaluation

Appendix K, Coatings

Appendix L (2149), Standard Procedures for Explosion Testing Ferrous and Non-Ferrous Metallic Materials and Weldments

Appendix M, Supplemental Technical Requirements to ISO 9001:2000

DISTANCE SUPPORT INFORMATION

Contact the Navy Distance Support (Anchor Desk) via the web (<http://www.anchordesk.navy.mil/>), e-mail (help@AnchorDesk.navy.mil), or via the toll free number (1-877-4-1-TOUCH [86824]).

TMDER INSTRUCTIONS

Ships, training activities, supply points, depots, Naval Shipyards and Supervisors of Shipbuilding are requested to arrange for the maximum practical use and evaluation of NAVSEA technical manuals (TMs). All errors, omissions, discrepancies, and suggestions for improvement to NAVSEA TMs shall be submitted as a Technical Manual Deficiency/Evaluation Report (TMDER). All feedback comments shall be thoroughly investigated and originators will be advised of action resulting there from.

The NAVSEA/SPAWAR Technical Manual Deficiency/Evaluation Report form, NAVSEA 4160/1 is included at the back of the TM.

Copies of form NAVSEA 4160/1 may also be downloaded from:

https://nsdsa.nmci.navy.mil/nsdsarepository/TMDER_BLANK_REV_9-2010-1.pdf

T9074-BD-GIB-010/0300 Rev 2

The following methods are available for generation and submission of TMDERs against unclassified TMs:

- For those with a Technical Data Management Information System (TDMIS) account, the most expedient and preferred method of TMDER generation and submission is via the TDMIS website at: <https://mercury.tdmis.navy.mil>.
- For those without a TDMIS account, generate and submit TMDER via the Naval Systems Data Support Activity (NSDSA) website at: https://mercury.tdmis.navy.mil/def_external/pubsearch.cfm. (TDMIS accounts may be requested at <https://nsdsa.nmci.navy.mil>.)
- When internet access is not available, submit TMDER via hardcopy to:

COMMANDER
CODE 310 TMDERs
NAVSURFWARCENDIV NSDSA
4363 MISSILE WAY, BLDG 1389
PORT HUENEME, CA 93043-4307
- TMDERs against classified/restricted (includes all NOFORN) TMs must be submitted using the hardcopy method cited above.
 - Urgent priority TM deficiencies shall be reported by Naval message with transmission to Port Hueneme Division, Naval Surface Warfare Center (Code 310), Port Hueneme, CA. Local message handling procedures shall be used. The message shall identify each TM deficiency by TM identification number and title. This method shall be used in those instances where a TM deficiency constitutes an urgent problem, (i.e., involves a condition, which if not corrected, could result in injury to personnel, damage to the equipment or, jeopardy to the safety or success of the mission).

Complete instructions for TMDER generation and submission are detailed on the NSDSA website at: <https://nsdsa.nmci.navy.mil/tmder/tmder.asp?lvl=1>.

LIST OF CHANGES

This revision corrects inconsistencies, omissions, and errors. This revision also provides updates with regard to specification improvements, technology developments, and lessons learned. This revision reflects input from producers as well as from public and private shipbuilders. The table below is a description of each change.

PARAGRAPH/ TABLE/ FIGURE	DESCRIPTION OF CHANGE
Main Body	Original Main Body paragraphs were converted to Chapter numbers and associated headings. For this reason, paragraph numbers in the Chapters no longer include a “Main Body” designation. Chapter paragraph designations are differentiated from Appendix paragraph numbers by the first place holder in the paragraph designation (e.g., 1.1 is a Chapter 1 paragraph number, A.1.1 is an Appendix A paragraph number). This nomenclature is maintained when cross referencing between Chapter paragraphs and Appendix paragraphs.
Tables	All tables have been re-numbered to coincide with the Chapter or Appendix in which they are located. For example, the first table in Appendix L is numbered L-1.
Figures	All figures have been re-numbered to coincide with the Chapter or Appendix in which they are located. For example, the first figure in Appendix L is numbered L-1.
2.2.1	Removed revision designation from referenced specification.
2.3	Removed revision designation from referenced documents.
3.5	Added normalizing and precipitation hardening to listing of heat treatments and added the word “documented” in the last sentence for clarity.
3.5.1	Removed revision designation from referenced heat treatment specification.
4.3.2	Editorial correction to remove erroneous review designator.
4.3.2.1	Added specimen removal and machining procedures with specific consideration for minimizing hydrogen loss to the list of critical procedures.
4.6.1	Revised wording for clarity.
4.6.2	Editorial correction.
A.1.1	Editorial.
A.1.2	Added a maximum thickness limit of 4 inches for HSLA-100 plates with 100 ksi minimum tensile yield strength. Editorial.
A.3.1	Editorial.
Table A-1	Editorial insertion of fractional thicknesses and SI units. Modified the upper thickness limit of HSLA-100 Comp 2 to 1 ⁵ / ₈ inch. Modified lower limit of nickel for HSLA-100 Comp 2 plate. Deleted note 4 on a lower allowance limit on nickel for HSLA-100 for thicknesses of 1 ⁵ / ₈ inch and less. Renumbered remaining notes.
Table A-2	Editorial insertion of fractional thicknesses and SI units. Defined yield strength as 0.2 percent offset.
Table A-3	Editorial insertion of fractional thicknesses and SI units. Increased the minimum Charpy requirement at -120 °F to 105 ft-lbs from 100 ft-lbs. Removed notes 5 and 6 from Table A-3 which allowed reduced fracture requirements for HSLA-80 at the request of the purchaser.
A.3.5.a	Editorial insertion of SI units.
A.3.5.c	Inserted a restriction for a single quenching operation from the precipitation heat treatment for batch type furnaces loads and that multiple quenching operations from batch loads in the precipitation heat treatment furnace shall not be used.
A.3.5.d	Inserted a requirement for digital photographs and requirements for product identification in the sketch of the furnace load.
A.3.5.e	Inserted a requirement for a process to maintain the quench tank effectiveness (e.g., flow rate and water capacity) to be similar to that used during the first article qualification.

T9074-BD-GIB-010/0300 Rev 2

PARAGRAPH/ TABLE/ FIGURE	DESCRIPTION OF CHANGE
A.3.5.f	Inserted a new section to specify and allow an alternate thermal survey to the requirements of SAE AMS-H-6875.
A.3.5.1	Inserted a requirement for a thermal hydrogen soak after hot rolling of all plates over 3 inches, unless otherwise approved by NAVSEA.
A.3.6.1.e	Defined the relevant indications for MT after plate weld repair as only linear.
A.3.6.1.g	Modified requirement regarding underfill to be consistent with Appendix B.
A.3.6.1.h	Defined the heat affected zones as the ½ inch of base metal adjacent to the plate repair weld for MT inspection.
A.3.6.1.k	Editorial.
A.3.6.2	Editorial insertion of SI units.
A.3.7.1	Editorial insertion of SI units.
A.3.7.3	Editorial insertion of SI units.
Table A-4	Editorial.
Table A-5	Editorial.
Table A-6	Removed requirements for thicknesses greater than 6 inches.
A.3.7.4	Editorial insertion of SI units.
A.3.7.5	Editorial insertion of SI units.
A.3.7.8	Editorial insertion of SI units.
Table A-7	Editorial and removed requirements for thicknesses greater than 6 inches.
Table A-8	Editorial.
Table A-9	Editorial.
Table A-10	Removed requirements for thicknesses greater than 6 inches.
A.3.8	Consolidated requirements from A.4.4.2.7 to be consistent with Appendix B and to clarify the difference between Type I and Type II plate.
A.3.8.1	Modified wording to define requirements for recording of plate thicknesses measurements. Added Figure A-5 for recording results of UT soundness testing.
A.3.13	Editorial.
A.4.1	Editorial.
A.4.3	Editorial.
A.4.3.1	Modified the wording to clarify the required sampling for first article testing.
Table A-11	Editorial and removed the note allowing HSLA-80 not to be explosion bulge tested.
A.4.4.1.1	Inserted a section that the lot definition for chemical analysis be in accordance with 4.4.1.1 and renumbered the follow sub-paragraphs of A.4.4.1.
A.4.4.2.3	Added wording provide a written definition of the sampling location for tensile tests.
A.4.4.2.4.1	Added wording provide a written definition of the sampling location for Charpy tests and to define the orientation of the test specimen notch.
A.4.4.2.4.2	Added wording provide a written definition of the sampling location for dynamic tear tests and to define the orientation of the test specimen notch.
A.4.4.2.6	Corrected typo and inserted reference.
A.4.4.2.7	Deleted paragraph and moved requirements to A.3.8.
A.4.6.1	Modified wording to require conformance inspection samples selected in accordance with A.4.4.2.2 shall be analyzed in accordance with 4.5.
A.4.6.3.1	Editorial.
A.4.6.3.2	Added wording to define the orientation of the test specimen notch.

xxx

PARAGRAPH/ TABLE/ FIGURE	DESCRIPTION OF CHANGE
A.4.6.4	Editorial to remove ultrasonic testing from section.
A.4.6.5	Added section specifically for ultrasonic examination and added an allowance that one coat each of pretreatment and primer may be applied to the scanned surface.
A.4.6.5.1	Added section to specify that ultrasonic soundness inspection shall be performed and accepted to ASTM A435 including the Supplementary Requirements of S1.
A.4.6.5.2	Added section to specify that ultrasonic thickness inspection shall be performed in accordance with Appendix J and meet the requirements of Table A-5 and A-6. Added wording to specify that plates purchased to a lb/ft ² basis require no ultrasonic inspection for thickness.
A.4.6.6	Added a section for documentation of thickness and soundness measurements to be transmitted with the material.
A.4.6.7	Editorial.
A.4.6.7.1	Defined prior austenite grain size determination as a first article requirement.
A.4.6.7.2	Editorial.
A.4.6.8	Added wording to define the thickness of explosion bulge test specimens when required.
A.6.2	Modified as necessary to account for changes in requirements.
Figure A-5	Added Figure A-5, a form for recording UT soundness testing results.
B.1.2	Added additional clarification regarding classification of plates over ½ inch (13 mm) thick to be consistent with A.1.2.
Table B-1, Note 1	Added a maximum tolerance for sulfur of 0.002 percent over the maximum specified for each product.
Table B-1, Note 2	Editorial insertion of SI units.
B.3.3.1	Editorial.
Table B-2	Editorial clarification of thickness ranges.
B.3.4	Inserted the option of substituting Charpy V-notch impact testing for dynamic tear testing when specified.
Table B-3	Corrected the SI unit conversion of 4-inch thickness.
Table B-4	Editorial.
Table B-4, Note 1	Modified reference sections of sampling and location of test samples.
Table B-4, Note 4	Editorial.
B.3.5.a	Inserted a restriction prohibiting multiple quenching operations from batch loads in the precipitation heat treatment furnace.
B.3.5.d	Inserted a requirement for digital photographs and requirements for product identification in the sketch of the furnace load.
B.3.5.e	Inserted a requirement for a process to maintain the quench tank effectiveness to be similar to that used during the first article qualification.
B.3.5.f	Inserted a new section to specify and allow an alternate thermal survey to the requirements of SAE AMS-H-6875.
B.3.5.1	Inserted a requirement for a thermal hydrogen soak after hot rolling of all plates over 3 inches.
Table B-5	Editorial correction of SI unit conversion.
B.3.5.2	Editorial.
B.3.6.1	Added option to repair weld to other standards when specified.
B.3.6.1.e	Editorial.
B.3.6.1.h	Defined the heat affected zones for MT inspection.

T9074-BD-GIB-010/0300 Rev 2

PARAGRAPH/ TABLE/ FIGURE	DESCRIPTION OF CHANGE
B.3.6.2	Deleted a reference to ASTM A435 for ultrasonic inspection acceptance standards and substituted requirements of section B.3.7. Added option for other ultrasonic inspection acceptance standards when specified. Inserted a requirement for laminar edge defect weld repairs.
B.3.7	Modified wording to clarify the requirements for ultrasonic inspection for soundness and ultrasonic measurement for decimal thickness and the difference between Type I and Type II plate.
B.3.7.1	Modified section to clarify requirements on how thickness and internal soundness measurements will be prepared and reported.
Table B-6	Editorial corrections.
Table B-8	Editorial corrections.
Table B-9	Editorial corrections and removed requirements for thicknesses over 8 inches. Added note 4 that flatness shall be measured without constraints.
Table B-10	Editorial corrections and added note 1 that chamber shall be measured without constraints.
Table B-11	Editorial corrections.
B.3.11	Added other approved procedures material identification.
B.3.12	Editorial.
B.4.1	Added title.
B.4.3	Editorial.
B.4.4.1.1	Inserted a lot definition for chemistry by reference to 4.4.1.1.
B.4.4.1.2 - .4	Changed paragraph designations.
B.4.4.2.4	Editorial reference change.
B.4.4.2.4.1	Modified thickness limits for Charpy V-notch test location.
B.4.6.1.1	Editorial.
B.4.6.3.2	Editorial correction.
B.4.6.4	Editorial.
B.4.6.5	Added section specifically for ultrasonic examination and added an allowance that one coat each of pretreatment and primer may be applied to the scanned surface.
B.4.6.5.1	Added section to clarify requirements that ultrasonic soundness inspection shall be performed and accepted to ASTM A435.
B.4.6.5.2	Added section to clarify requirements on ultrasonic thickness inspection Added wording to specify that plates purchased to a lb/ft ² basis require no ultrasonic inspection for thickness.
B.4.6.6	Added a section for documentation of thickness and soundness measurements to be transmitted with the material.
B.6.2	Modified as necessary to account for changes in requirements.
D.3.2.1	Added wording further restricting the use of chaplets and the use of internal chills, unless approved by NAVSEA.
D.3.3	Added definitions for both as cast thickness (CT) and as-heat-treated thickness (T).
D.3.4	Modified the statement that the tensile properties at any location in the casting at an equivalent depth below the heat treated surface as the location of the tensile specimens in the prolongation or test block is restricted to the first article casting.
Table D-2	Modified to include tensile strength by heat treated thickness and by depth from the heat treated surface and modified the reduction in area requirement to provide further assurance of no diffusible hydrogen problems.

PARAGRAPH/ TABLE/ FIGURE	DESCRIPTION OF CHANGE
D.3.5	Modified the wording to state that impact properties shall meet only the requirements of Table D-3 and that the impact properties at any location in the casting at an equivalent depth below the heat treated surface as the location of the tensile specimens in the prolongation or test block is restricted to the first article casting.
Table D-3	Modified to consolidate all impact properties into this Table specified by heat treated thickness and by depth of specimens from the heat treated surface.
D.3.6	Added a requirement to allow for additional conformance testing for large as cast thickness (CT) castings.
D.3.7	Editorial.
D.3.7.a	Editorial clarification of heat treatment sequence. Reduced maximum allowed tempering temperature. Corrected wording to remove austenitization heat treatment from single quench load prohibition. Clarified the requirement for the test block to accompany the casting in all thermal treatments. Allowance added for alternate quench media exposure arrangements between the test block and the casting with customer approval.
D.3.7.b	Modified requirements on thermocouple temperature tolerances on tempering and added temperature tolerance controls between the thermocouples on the thickest casting and test block.
D.3.7.d	Reworded for clarity.
D.3.7.e	Inserted a requirement for digital photographs and requirements for product identification in the sketch of the furnace load.
D.3.7.f	Editorial clarification.
D.3.7.g	Modified wording to require hydrogen anneal to be performed to the times listed in Table D-4.
Table D-4	Added Table D-4 with a list of hydrogen anneal times based on section size.
D.3.7.1	Editorial.
D.3.9	Modified wording for required cleaning and material removal before heat treatment.
D.3.10	Modified wording to clarify requirements for internal and external soundness.
D.3.11	Editorial.
D.3.11.2	Added clarifying wording on the welding preheat and interpass controls.
D.3.11.3	Editorial clarification.
D.4.3	Editorial.
Table D-5	Editorial.
D.4.3.1.1	Added a reference to Figure D-1 to provide guidance as to the complexity required for a first article casting. Added an allowance for the foundry to submit an alternate casting design to Figure D-1 for NAVSEA approval.
D.4.3.1.1.1	Added a requirement for the purchaser to integrate with the qualified foundry industrial base and ensure design manufacturability with the expectation of achieving acceptable properties throughout the cast article for new designs. Included a requirement for NAVSEA notification when agreement of manufacturability cannot be established.
D.4.3.1.2	Added a clarifying statement that a prolongation or test block is required for all castings.
D.4.3.1.2.1	Clarified that the prolongation or test block shall remain attached to the casting through the quenching operation. Added clarifying wording that the prolongation or test block shall not obstruct quenchant flow through all thermal cycles.
D.4.3.1.2.2	Editorial.
Table D-6	Added note to provide additional definition to the test block length and adequate material for possible retest.
D.4.3.1.2.3	Editorial for clarity of heat treatment requirements of test blocks and that quenching shall be the same as that received by the casting it represents.
D.4.3.1.3	Editorial.

T9074-BD-GIB-010/0300 Rev 2

PARAGRAPH/ TABLE/ FIGURE	DESCRIPTION OF CHANGE
D.4.3.2.2	Added clarification of the location of test specimens and added reference to Figure D-1 for guidance.
D.4.3.2.2.1	Added clarification of the T/2 test specimen locations.
D.4.3.2.3	Editorial.
D.4.3.2.4	Editorial.
D.4.3.2.5	Editorial.
D.4.3.2.6	Editorial.
D.4.3.2.7	Editorial.
D.4.3.2.9	Editorial.
D.4.4.1.1	Editorial.
D.4.4.2	Editorial changes for clarity and added an option to sample the casting for chemistry if the heat analysis is inadequate or does not represent the heat.
D.4.4.3	Added additional information on testing location.
D.4.4.4	Added reference to 6.2.
D.4.5.1	Editorial.
D.6.2	Modified as necessary to account for changes in requirements.
Figure D-1	Added drawing of a sample first article casting.
Figure D-2	Added schematic showing test specimen location within the test block for castings greater than 6 inches thick.
E.3.6.a	Reduced maximum tempering temperature for increased margin prior to reaching the lower critical temperature.
E.3.6.c	Specified that, when approved by NAVSEA, HY-100 forgings shall be stress relieved at 1075 °F.
E.3.6.d	Deleted.
E.4.5.2	Added allowance to specify alternate to ASTM A435 as UT acceptance criteria.
E.6.2	Modified as necessary to account for changes in requirements.
Table G-1	Corrected product analysis for sulfur.
Table G-2	Added and corrected SI units.
Table G-3, Note 1	Editorial.
Table G-3, Note 3	Added a requirement for notch orientation for Charpy V-notch specimens.
G.3.5	Added allowance for other types of quenching media in addition to water. Added a requirement that all bars in one furnace load are to be quenched at the same time, multiple quench loads are not allowed.
G.3.6	Editorial.
G.3.9.a & c	Editorial correction of SI units.
G.3.9.f	Added SI units.
G.4.1	Editorial.
G.4.4.2.3	Added definition to the mechanical test specimen locations. Added SI units.
G.4.4.2.3.a	Added definition to the mechanical test specimen locations. Added SI units.
G.4.4.2.3.b	Added definition to the mechanical test specimen locations. Added SI units.
G.4.4.2.3.1	Editorial. Deleted reference to ASTM A370 for test specimen location.
G.4.4.2.3.2	Editorial. Deleted requirement that multiple bars are to be sampled.
G.4.4.2.3.3	Added requirement for two dynamic tear tests instead of one for each five tons of product.
G.4.5.2	Changed order of inspection requirements.

PARAGRAPH/ TABLE/ FIGURE	DESCRIPTION OF CHANGE
G.4.5.3	Editorial.
G.4.5.3.1	Added definition of discontinuity that is cause for rejection during ultrasonic inspection.
G.4.6.2	Editorial.
G.4.7	Editorial.
Figure G-1	Added new corrected Figure G-1 to reflect correct number of impacts test specimens.
I.1.1	Editorial.
Table I-1	Editorial.
I.3.5.c	Clarification that all heads in the same tempering or stress relief furnace load are to be quickly cooled at the same time.
I.3.6.1.e	Editorial.
I.3.6.1.g	Modified requirement regarding underfill to be consistent with Appendix B.
I.3.6.1.h	Added wording to define the area of base metal adjacent to the weld repair that is to be MT inspected.
I.3.8	Added wording that the thickness tolerances to be met are those provided in Appendix B.
I.3.9	Modified wording on the thickness of heads to be ultrasonically inspected for soundness and that the requirements of Appendix B shall be met.
I.4.1	Editorial.
I.4.4.1.3.2	Editorial.
I.4.4.1.4.1	Editorial.
I.4.4.1.4.2	Editorial.
I.4.4.2.1	Editorial and provided a definition of the thickness (T) to be used.
I.4.4.2.2	Corrected error in specification requiring 3T on thicknesses over 6 inches thick changed back to previously required 1T for location of test specimens in MIL-S-24451.
I.4.4.2.3	Editorial correction.
I.4.4.2.4	Editorial.
I.4.4.2.5	Editorial.
I.4.5.1	Provided definition of requirements for visual and dimension inspection.
I.4.6.1	Editorial.
I.4.6.5	Editorial.
I.6.2	Modified as necessary to account for changes in requirements.
Figures I-1 and I-2	Added SI units.
Appendix J, Title	Editorial.
J.1.1	Editorial.
J.3.1	Editorial.
J.3.3	Editorial.
J.3.4	Editorial.
J.4.1	Editorial.
J.4.1.2.1	Editorial.
J.4.1.3	Editorial.
J.4.2.1	Editorial.
J.4.3	Editorial and added mechanical test to reports that when specified shall be made available to NAVSEA.

T9074-BD-GIB-010/0300 Rev 2

PARAGRAPH/ TABLE/ FIGURE	DESCRIPTION OF CHANGE
Figure J-1	Deleted Figure J-1 from this Appendix and moved to Appendix A as Figure A-5.
Figure J-2	Editorially updated and moved to Figure J-1.

CHAPTER 1 SCOPE

1.1 SCOPE.

This specification covers the general requirements, quality assurance provisions, test procedures, and instructions for preparation for delivery for high-strength steel plate, shapes, bars, castings, forgings, and other products.

1.2 CLASSIFICATION.

High-strength steel shall be furnished in the types, classes, sizes, and shapes specified in the appropriate appendix (see 6.2).

T9074-BD-GIB-010/0300 Rev 2

THIS PAGE INTENTIONALLY LEFT BLANK

CHAPTER 2 APPLICABLE DOCUMENTS

2.1 GENERAL. The documents listed in this Chapter are specified in Chapters 3 and 4 and Appendices A through M of this specification. This Chapter does not include documents cited in other Chapters of this specification or recommended for additional information or as examples. While every effort has been made to ensure the completeness of this list, document users are cautioned that they must meet all specified requirements of documents cited in Chapters 3 and 4 and Appendices A through M of this specification, whether or not they are listed.

NOTICE: Some of the following documents are scheduled to be canceled and replaced by other documents. Until the new documents are issued, current references will be retained.

2.2 GOVERNMENT DOCUMENTS.

2.2.1 Specifications, Standards, and Handbooks.

FEDERAL SPECIFICATIONS

- TT-P-645 - Primer, Paint, Zinc Chromate, Alkyd Type
- TT-P-664 - Primer Coating, Alkyd, Corrosion-Inhibiting, Lead and Chromate Free, VOC-Compliant
- TT-P-1757 - Primer Coating, ALKYD Base, One Component

FEDERAL STANDARDS

- FED-STD-183 - Continuous Identification Marking of Iron and Steel Products
- FED-STD-595 - Colors

DEPARTMENT OF DEFENSE STANDARDS

- MIL-STD-1689 - Fabrication, Welding and Inspection of Ships Structure
- MIL-STD-2035 - Nondestructive Testing Acceptance Criteria
- MIL-STD-45662 - Calibration Systems Requirements

(Copies of these documents are available online at <https://assist.dla.mil/quicksearch/> or <https://assist.dla.mil/>.)

2.2.2 Other Government Documents, Drawings, and Publications. The following other Government documents, drawings, and publications form a part of this document to the extent specified herein. Unless otherwise specified, the issues are those cited in the solicitation.

NAVSEA TECHNICAL PUBLICATIONS

- S9074-AQ-GIB-010/248 - Requirements for Welding and Brazing Procedure and Performance Qualification
- T9074-AD-GIB-010/1688 - Requirements for Fabrication, Welding, and Inspection of Submarine Structure
- T9074-AS-GIB-010/271 - Requirements for Nondestructive Testing Methods
- T9074-BC-GIB-010/0200 - Filler Materials for Critical Applications: Requirements for Flux-Cored Welding Electrodes, Bare Welding Electrodes and Fluxes, and Covered Welding Electrodes for Low-Alloy Steel Applications

(Copies of these documents are available from the Naval Logistics Library, 5450 Carlisle Pike, Mechanicsburg, PA 17055 or online at <https://nll1.ahf.nmci.navy.mil/>.)

T9074-BD-GIB-010/0300 Rev 2

2.3 NON-GOVERNMENT PUBLICATIONS. The following documents form a part of this document to the extent specified herein. Unless otherwise specified, the issues of these documents are those cited in the solicitation or contract.

ASTM INTERNATIONAL (ASTM)

- ASTM A6 - Standard Specification for General Requirements for Rolled Structural Steel Bars, Plates, Shapes, and Sheet Piling (DoD-adopted)
- ASTM A20 - Standard Specification for General Requirements for Steel Plates for Pressure Vessels (DoD-adopted)
- ASTM A29 - Standard Specification for Steel Bars, Carbon and Alloy, Hot-Wrought and Cold-Finished, General Requirements for (DoD-adopted)
- ASTM A370 - Standard Test Methods and Definitions for Mechanical Testing of Steel Products (DoD-adopted)
- ASTM A435 - Standard Specification for Straight-Beam Ultrasonic Examination of Steel Plates (DoD-adopted)
- ASTM A505 - Standard Specification for Steel, Sheet and Strip, Alloy, Hot-Rolled, and Cold-Rolled, General Requirements for (DoD-adopted)
- ASTM A673 - Standard Specification for Sampling Procedure for Impact Testing of Structural Steel (DoD adopted)
- ASTM A703 - Standard Specification for Steel Castings, General Requirements, for Pressure-Containing Parts
- ASTM A751 - Standard Test Methods, Practices, and Terminology for Chemical Analysis of Steel Products
- ASTM A770 - Standard Specification for Through-Thickness Tension Testing of Steel Plates for Special Applications
- ASTM A788 - Standard Specification for Steel Forgings, General Requirements (DoD-adopted)
- ASTM E8 - Standard Methods for Tension Testing of Metallic Materials (DoD-adopted)
- ASTM E23 - Standard Test Methods for Notched Bar Impact Testing of Metallic Materials (DoD-adopted)
- ASTM E29 - Standard Practice for Using Significant Digits in Test Data to Determine Compliance with Specifications (DoD Adopted)
- ASTM E112 - Standard Test Methods for Determining Average Grain Size (DoD-adopted)
- ASTM E208 - Standard Method for Conducting Drop-Weight Test to Determine Nil-Ductility Transition Temperature for Ferritic Steels
- ASTM E381 - Standard Method for Macroetch Testing Steel Bars, Billets, Blooms, and Forgings
- ASTM E604 - Standard Test Method for Dynamic Tear Testing of Metallic Materials (DoD-adopted)
- ASTM E1019 - Standard Test Methods for Determination of Carbon, Sulfur, Nitrogen, and Oxygen in Steel and in Iron, Nickel, and Cobalt Alloys

(Copies of these documents are available from ASTM International, 100 Barr Harbor Dr., P.O. Box C700, West Conshohocken, PA 19428-2959 or online at www.astm.org.)

AMERICAN WELDING SOCIETY (AWS)

- AWS B4.0 - Standard Methods for Mechanical Testing of Welds (DoD-adopted)

(Copies of this document are available from the American Welding Society, 550 N.W. LeJeune Road, Miami, FL 33126 or online at www.aws.org.)

AMERICAN NATIONAL STANDARDS INSTITUTE/AMERICAN SOCIETY FOR QUALITY (ANSI/ASQ)

- ANSI/ASQ ISO 9001:2000 - Heat Treatment of Steel Raw Materials

(Copies of this document are available from the American Society for Quality, 600 North Plankinton Ave., Milwaukee, WI 53203 or online at www.asq.org.)

AMERICAN NATIONAL STANDARDS INSTITUTE/AMERICAN WELDING SOCIETY (ANSI/AWS)

ANSI/AWS A3.0 - Standard Welding Terms and Definitions

(Copies of this document are available from the American Welding Society, 550 N.W. LeJeune Road, Miami, FL 33126 or online at www.aws.org.)

SAE INTERNATIONAL (SAE)

SAE AMS-H-6875 - Heat Treatment of Steel Raw Materials

(Copies of this document are available from SAE World Headquarters, 400 Commonwealth Drive, Warrendale, PA 15096-0001 or online at www.sae.org.)

(Non-Government standards and other publications are normally available from the organizations that prepare or distribute the documents. These documents also may be available in or through libraries or other informational services.)

2.4 ORDER OF PRECEDENCE.

In the event of a conflict between the text of this document and the references cited herein, the text of this document takes precedence. In the event of a conflict between Chapters 1 through 6 and the appendix, the appendix takes precedence. Unless otherwise specified, any reference to a paragraph within this document includes all applicable sub-paragraphs. Nothing in this document, however, supersedes applicable laws and regulations unless a specific exemption has been obtained.

T9074-BD-GIB-010/0300 Rev 2

THIS PAGE INTENTIONALLY LEFT BLANK

CHAPTER 3 REQUIREMENTS

3.1 FIRST ARTICLE.

Unless otherwise specified (see 6.2), a sample shall be subjected to first article inspection (see 4.3). A first article inspection report shall be prepared in accordance with the data ordering document included in the contract or order (see 6.3). Naval Sea Systems Command (NAVSEA) is the approval authority for the first article program and is responsible for initial qualification, and recertification of vendors (see 4.3.3). First article approval based upon previous specifications for the products listed in this specification are not valid for this specification, unless otherwise approved by NAVSEA. Prior to the initiation of the first article production, a manufacturer shall submit a detailed qualification plan to NAVSEA for approval outlining the manufacturing processes and testing proposed to meet the requirements herein. The manufacturer must also submit a Process Control Plan as defined in 4.3.2 for review for adequacy prior to the initiation of first article production.

3.2 MATERIAL.

All material (plate, bar, forging, etc.) covered by this specification shall be made by the same process as that used for the production of the first article test items with any amendments/revisions as specifically allowed as specified herein. As a minimum, the steel shall be fully killed and produced to fine grain practice. Melting practice may include argon-oxygen decarburization (AOD), other refining processes, or remelting by the vacuum arc (VAR) or electroslag remelt (ESR) processes. When specified in the applicable appendix, the steel shall be vacuum degassed, otherwise, for other than VAR or ESR, the molten steel may be vacuum degassed prior to or during pouring. The steel may be cast by conventional methods or, for plate, sheet, coil, and bar, may be continuous cast. When continuous cast slab is used, the ratio of reduction in cross-sectional area from the slab to the plate or bar shall be a minimum of 3:1. When specified, virgin material shall be used (see 6.2). Other production practices, if approved by NAVSEA, may be used to produce this steel.

3.2.1 Recycled, Recovered, or Environmentally Preferable Materials. Recycled, recovered, or environmentally preferable materials should be used to the maximum extent possible provided that the material meets or exceeds the operational and maintenance requirements, and promotes economically advantageous life cycle costs.

3.2.2 Ingot Discard. Sufficient discard shall be taken from each ingot to ensure freedom from piping and to prevent undue segregation. The extent of ingot cropping shall be in accordance with the most recent revision of the Process Control Plan per the requirements in 4.3.2.

3.3 CHEMICAL COMPOSITION.

The chemical composition of the heat and the product shall be as specified in the applicable appendix. When the multiple ladle (heat) casting process is used, each ladle (heat) shall meet the specified chemical composition including tolerances. In cases where both heat and product analyses are determined, the product analysis shall be used to determine acceptance or rejection.

3.4 MECHANICAL PROPERTIES.

The material shall meet the mechanical properties (strength, elongation, Charpy V-notch, etc.) as specified in the applicable appendix.

3.5 HEAT TREATMENT.

Heat treatment shall be defined as any of the following processes: homogenization/normalization, austenitization, quenching (in any medium), tempering, precipitation hardening, stress relief, and hydrogen soak. Heat treatment shall be in accordance with the requirements in SAE AMS-H-6875 and as specified below and in the applicable appendix, unless otherwise determined to be acceptable by NAVSEA and documented in the Process Control Plan per 4.3.2.

3.5.1 Heat Treatment Equipment and Controls. Continuous or automatic heat treating equipment may be employed provided such equipment produces heat treated material that meets the requirements specified herein. The furnaces and temperature recording equipment shall be shown to correlate with the actual temperature of the material and shall be maintained and calibrated on a regular scheduled basis in accordance with the requirements in SAE AMS-H-6875 or as permitted in 3.5. The temperature of the material shall be recorded during the heating and, if applicable, stress relieving cycles of the heat treatment. After the charge reaches the selected temperature control setting, the furnace shall maintain the temperature of the material at any point in the working zone within ± 25 °F (± 14 °C).

T9074-BD-GIB-010/0300 Rev 2

3.5.2 Heat Treatment Record. The Contractor shall maintain a complete record of the heat treatments given each product (each plate, casting, forging, shape, etc.), including stress relief, and shall prepare a record of the heat treatment as part of the certification report (see 4.1.6). For batch-type furnaces, the heat treatment record shall include all the information presented on [Figure 3-1](#) and [Figure 3-2](#) and a verification of inspection record, unless otherwise indicated in an applicable appendix.

3.5.3 Working Zone Temperature Survey. Working zone temperature surveys shall be in accordance with SAE AMS-H-6875 or as permitted in 3.5. However, when specified (see 6.2), furnace working zone temperature surveys of batch-type furnaces shall be conducted with a typical, nominal, or simulated production load in the furnace.

3.5.4 Load Distribution. In addition to requirements in applicable appendices, during heat treatment, the items shall be distributed and, when necessary, properly supported by fixtures to permit complete and uniform heat treatment, to minimize distortion, and to allow free circulation of protective atmosphere (when used) to each item. Prior to heat treatment, fixtures shall be visually inspected for foreign material. Foreign material shall be removed prior to heat treatment unless it is positively identified as a material that does not contain detrimental material. All fixture surfaces in contact with heat treated items shall be manufactured from the material that is not detrimental. To meet these requirements, 3.5.4.a through 3.5.4.e below shall apply:

- a. Items shall be placed only within the working zone dimensions that are determined as part of the 3.5.3 temperature survey.
- b. Items in the load shall contact only supporting fixtures, other furnace load items, or attached thermocouples.
- c. Through holes and blind holes shall not be blocked in a manner that would prevent entry of protective atmosphere (when used).
- d. Thermal expansion and distribution of the load shall be considered so that distortion of items is minimized.
- e. In gas or oil-fired furnaces, items shall be distributed to avoid localized heating by flame impingement.

3.5.5 Quenchant Temperature. When quenching (see applicable appendices) is required, the water temperature at the initiation of the quenching operation shall not exceed 80 °F.

3.5.6 Contact Thermocouples. Except when specified otherwise in the applicable appendices or unless specially approved by NAVSEA based on data presented at first article approval, for batch type furnaces a minimum of three thermocouples shall be attached to the furnace load. The hot junctions (or the caps of sheathed thermocouples) shall be in contact with the items.

3.6 SURFACE QUALITY.

Surface quality of the material shall be as specified in the applicable appendix. Billets and other material used in the production of forgings shall not be weld repaired.

3.7 DIMENSIONS AND TOLERANCES.

Dimensions and tolerances of the material shall be as specified in the applicable appendix.

3.8 IDENTIFICATION MARKING.

Identification and marking of the material shall be as specified in the applicable appendix.

3.9 DESCALING AND CLEANING.

Descaling and cleaning of the material shall be as specified in the applicable appendix.

3.10 INTERNAL SOUNDNESS.

Soundness of the material shall be as specified in the applicable appendix.

3.11 EXPLOSION TESTING.

Unless specified as “not required” in the applicable appendix, explosion testing is required and shall meet the requirements of Appendix L. Two explosion crack starter specimens are required, unless specified otherwise in the applicable appendix. Performance requirements shall be as specified in Appendix L, unless alternate (or additional) requirements are specified in the applicable appendix.

- A. Procedure No. _____ Revision _____ Date _____
- B. Heat treatment facility _____
- C. Item material specification _____ Revision _____ Amend. _____ Interim Change _____
- D. Material: Composition _____ Type _____ Condition _____ Grade _____ Class _____
- E. Time and temperature:

Heat Treatment	Aim Temperature	Tolerance ^{1/}	Holding Time
Preheating			
Annealing			
Solution Treating			
Precipitation Hardening			
Austenitizing			
Tempering			
Stress Relieving			

* Includes temperature tolerance if the tolerance is other than ± 25 °F (± 14 °C).

- F. Will items be quenched? Yes _____ No _____ If yes, identify:
1. Quenching method (e.g., immersion, spray, etc.) _____
 2. Quenching medium (include additives, if any) _____
- G.
1. If not quenched, how are the items cooled? _____
 2. Cooling rate (if specified by the contract document) _____
- H. Working zone atmosphere:
1. Type of atmosphere: _____
 2. Dew point (maximum): _____ °F or °C
 3. Temperature above which the dew point must be controlled if other than 600 °F (316 °C) _____
 4. Flow rate: _____ cubic feet per hour
 5. Vacuum – Maximum pressure: _____ torr (mm Hg) or _____ microns Hg.
 6. Type of inert gas backfill (if used): _____ Backfill dew point (maximum) _____ °F or °C

^{1/} Enter "NA" when an item does not apply.

^{2/} A single heat treatment procedure may cover more than one heat treatment process, provided that the required information for each process is clearly distinguished.

Figure 3-1. Heat Treatment Procedure Information. ^{1/}, ^{2/}

T9074-BD-GIB-010/0300 Rev 2

- A. Heat treatment facility _____
- B. Items heat treated _____
- C. Lot numbers or serial numbers _____
- D. Heat treatment procedure used (including revision and date of revision) _____
- E. Date of heat treatment _____
- F. Time/temperature data (the original temperature chart or the original manually recorded data). Include a standard time interval, such as one hour, or the starting time and chart speed marked on the chart.
- G. Specific furnace(s) used: _____
- H. Method of thermocouple attachment (batch furnace only): _____
- I. Quenching Information
1. Was the item quenched in accordance with the heat treatment requirements of the applicable appendix?
Yes ___ No ___
(If items were quenched, answer 2 through 14 below. If items are not quenched, answer 15 below.)
 2. Quenching method: immersion _____ spray _____
other (specify) _____
 - *3. Quenching medium: _____
Additives (generic type & amount) _____
 4. Approximate quench tank capacity: _____ gallons (liters)
 5. Approximate rate of flow to quench tank: _____ gallons/minute (liters/minute)
 6. Type, number and locations of agitation devices in quench tank: _____

 7. Approximate flow rate of quench sprays: _____ gallons/minute (liters/minute)
 8. Maximum time interval between removal from the furnace and the start of quenching: _____ minutes
 9. Is the item quenched individually: Yes ___ No ___
 10. If items are not quenched individually, how many items are quenched simultaneously? _____
 11. Minimum time in quenchant: Hours _____ Minutes _____
 12. Quenchant temperature: _____ °F or °C at start, _____ °F or °C at completion
 13. Surface temperature of the thickest section when removed from quenchant (not required for items of uniform thickness quenched in water provided the minimum time in the quenchant is at least four minutes per inch of thickness):
_____ °F or °C
 14. Forgings over 2500 pounds: Fixtured during quenching: Yes ___ No ___
Orientation in quenching medium (a sketch or reference to a standard practice is acceptable). _____
 15. If not quenched, how are the items cooled? _____

Figure 3-2. Information to be Documented on the Heat Treatment Record.

J. Furnace Information:

1. Furnace type(s):

Batch furnace _____ Salt bath _____ Type of salt _____

Vacuum furnace _____ Integral quench: Yes ___ No ___

Continuous furnace _____ Furnace fuel: _____

2. Method of preventing flame impingement: _____

K. Temperature measurement and control information:

1. Thermocouple information:

(a) How many thermocouples were used? Contact _____ Noncontact _____

(b) Describe the location of each thermocouple (may provide a sketch)

2. How was working zone temperature recorded?

Automatically _____

Manually _____ (Monitoring interval) _____

3. How was working zone temperature controlled?

Automatically _____

Manually _____ (Monitoring interval) _____

4. If manual temperature control was used, how was the temperature adjusted (may reference a written standard practice): _____

5. If thermocouples were not used, briefly describe the type, number, and location of the temperature measuring devices used to indicate, record, and control temperature:

6. Distance between the thermocouples and the load in an oscillating furnace: _____ inches.

L. Furnace loading information:

1. General description of item distribution in the load (not required when a thermocouple is attached to each item in the load).

(a) Approximate weight or size of batch furnace load:

Pounds (Kilograms) _____ or no. of pieces _____ and size _____

(b) Approximate continuous furnace production rate: _____ pounds/hour

2. General description of the supporting method used.

M. Location of test coupons (when used) in relation to items and attached thermocouples (when used).

N. Furnace survey information:

1. Was this heat treatment used in conjunction with a temperature survey? Yes _____ No _____

Figure 3-2. Information to be Documented on the Heat Treatment Record – Continued.

T9074-BD-GIB-010/0300 Rev 2

THIS PAGE INTENTIONALLY LEFT BLANK

CHAPTER 4 VERIFICATION

4.1 RESPONSIBILITY FOR INSPECTION.

The Contractor is responsible for the performance of all inspection requirements as specified in the base document and in the applicable appendix of this specification. Except as otherwise specified in the contract or purchase order, the Contractor may use his own or any other facilities suitable for the performance of the inspection requirements specified herein, unless disapproved by the Government. The Government reserves the right to perform any of the inspections set forth in the specification where such inspections are deemed necessary to assure supplies and services conform to prescribed requirements.

4.1.1 Performance of Inspection. The performance of the inspections or tests set forth in this specification does not relieve the Contractor of his responsibility to provide a product that meets all requirements of this specification. Test specimens shall be stamped or otherwise marked for identification. Any applied marks shall remain on the test specimens until they are tested and necessary records are made. The test specimens shall not receive any treatment, working, straightening, or other processing, except for machining, that may result in changing the properties to be evaluated by the testing, except as provided in the specific test methods.

4.1.2 Examination of Material as Offered for Acceptance. All applicable examinations and tests required by this specification shall be performed on material as offered for acceptance as noted in the applicable appendices.

4.1.3 Quality System. The Contractor shall establish and maintain a quality system that is acceptable to the Buyer and as a minimum meets the requirements of ISO 9001:2000 with the supplemental technical requirements in Appendix M, or an equivalent.

4.1.3.1 Traceability System. As a minimum, the Contractor shall maintain a traceability system to ensure the proper identity of the material.

4.1.4 Product Quality Requirements. Every test prescribed by this specification, including, but not limited to, first article tests, production lot acceptance tests, and final inspection tests, whether performed by the Contractor or the Government, is a quality assurance tool intended to ensure a consistent manufacturing process and compliance with all requirements of this specification.

4.1.5 Responsibility for Compliance. All items must meet all requirements of Chapters 3 and 5 of this document and in the applicable appendix. The inspections set forth in this specification shall become a part of the Contractor's overall inspection system or quality program. The absence of any inspection requirements in the base specification and/or appendix, shall not relieve the Contractor of the responsibility of assuring that all products or supplies submitted to the Government for acceptance comply with all requirements of the contract or purchase order. Sampling for conformance neither authorizes submission of known defective material, either indicated or actual, nor does it commit the Government to acceptance of defective material.

4.1.6 Certification of Conformance. A certificate of conformance shall be prepared for each lot of material offered for acceptance, in accordance with the definition of the applicable appendix. The certificate shall include actual data of specified chemical and mechanical tests and a record of the final heat treatment (if applicable). Qualitative results of nondestructive tests and other inspections or tests shall be recorded on the certificate. In addition, the Contractor shall report the melt processes used and the melting source of the material if the Contractor is not the melter. The certificate shall state that each lot has been sampled, tested, and inspected in accordance with the specification requirements and that the manufacturer has maintained adequate manufacturing procedures demonstrated in first article testing as listed and maintained as specified in 4.3.2 and quality assurance practices to produce a product that meets the chemical and mechanical property requirements specified throughout the product. The certificate shall state that each lot meets all specification requirements and shall be signed by a responsible representative of the Contractor. Where test certificates issued by the manufacturer contain the above data requirements, a separate certificate of conformance will not be required. The certificate shall include the revision of the Process Control Plan used and the date of most recent first article approval or recertification.

4.2 CLASSIFICATION OF INSPECTIONS.

The inspection requirements specified herein are classified as follows:

- a. First article inspection (see 4.3).
- b. Conformance inspection (see 4.4).

T9074-BD-GIB-010/0300 Rev 2**4.3 FIRST ARTICLE INSPECTION.**

First article inspection shall consist of the tests specified in the applicable appendix. Variations from the approved qualification plan, including heat treatment, require approval by NAVSEA. If reheat treatment is used on the first article, heat treatment for procurement may be required to include the same number of heat treatment cycles, with the same definitions (i.e., time and temperature) as that used during first article production based on NAVSEA review of test data.

4.3.1 Sampling for First Article Inspection. For sheet, coil, and forgings, first article samples shall be taken from products rolled or forged from ingots. For plate and bar, first article samples shall be taken either from products rolled or forged from ingots or from continuously cast slab. First article materials shall be taken from the largest ingot or slab that can be produced from one heat of material. The material selected for first article testing shall be taken from the topmost portion of the ingot or the leading edge of the slab that is considered acceptable for use. As a minimum, the thickest plate, largest diameter bar or largest forging thickness to be produced at the mill shall be tested. A casting representative of the largest casting thickness to be qualified shall be tested. Sufficient material of all forms shall also be provided for explosion testing if this testing is required in the applicable appendix. Additional first article sampling requirements shall be as specified in the applicable appendix.

4.3.2 Process Control Plan. The manufacturer must demonstrate during first article testing that it has an adequate process to ensure the specified composition and mechanical properties are met throughout the product. The Process Control Plan shall contain information as further described in 4.3.2.1. This Process Control Plan will document the processes and manufacturing process control procedures/documents used in the production of the first article product. All processing on material offered for acceptance in conformance with this specification shall be the same as that performed on material submitted for first article testing as documented in the Process Control Plan with any amendments/revisions as specifically allowed as specified herein. This Process Control Plan and all documents referenced or listed in the Process Control Plan shall also be controlled documents. All previous revisions must be kept on file for audit, and the version of the Process Control Plan used during manufacture of procured products must be recorded for each delivered lot. The revision record of the Process Control Plan must also indicate any problems that have been identified by the manufacturer, customers, or NAVSEA with their product which required a Process Control Plan revision, including receipt inspection, fabrication, or in service and how these problems were adequately resolved and the necessary changes made in the manufacturing procedures to ensure that these problems will not occur in the future. The Process Control Plan associated with the first article, and a listing of referenced process documents which become part of the Process Control Plan, shall be submitted to NAVSEA for review for adequacy, prior to the initiation of first article production. The current revision of the Process Control Plan shall also be made available to the procuring activity. NAVSEA may request additional information be added to the submitted Process Control Plan. The Process Control Plan and subsequent revisions must be available to NAVSEA, or its designated representative, for audit. The manufacturer shall ensure that employees responsible for manufacturing and testing the approved product(s) understand the appropriate procedures (e.g., molding, heat treatment, nondestructive inspection, mechanical property testing) in the plan. Any amendments/revisions to this plan which could negatively affect the properties of the product must be supported by data and submitted to NAVSEA for review for acceptability. The employee training methods shall be available for auditors when requested. The manufacturer shall ensure that an up-to-date copy of the Process Control Plan, including any amendments/revisions, is readily available in the plant for use by auditors when evaluating compliance with procedures approved by first article testing and by employees.

4.3.2.1 Process Control Plan Contents. The Process Control Plan shall describe, as a minimum, the following critical processing procedures:

- a. Melting facility.
- b. Melting method, including refining and degassing procedures.
- c. Cropping practices to ensure all finished material will meet specification requirements.
- d. Casting procedures (as applicable), including molding materials.
- e. Ingot, plate, forging, and casting soaking treatments (as applicable).
- f. Minimum rolling or forging reduction ratios (as applicable).
- g. Minimum and maximum forging temperatures (as applicable).
- h. Heat treatment parameters (temperature, time, cooling method, and atmosphere for intermediate (in process) and final heat treatment).
- i. Heat treatment facilities (which facilities were used, etc.).
- j. Any lubricating, de-scaling, cleaning, or pickling operations used during manufacture.

- k. All processes that could negatively impact the final surface and near surface chemical composition of the delivered product.
- l. A specific Change Control Plan which specifies the criteria and plan to verify the acceptability of any change in the critical processing procedures as listed in the Process Control Plan.
- m. Procedures and processes for removing, machining, preparing, and testing of tensile specimens from first articles, prolongations, and/or test blocks with specific consideration for minimizing hydrogen loss from specimens between removal and testing.
- n. Additional requirements as specified in the appendices.

4.3.3 Re-Certification of First Article Approval. For all materials covered by this specification, re-certification of the first article approval of vendor facilities, processes, and manufacturing methods by NAVSEA is required every 5 years. This re-certification will verify that the requirements specified by NAVSEA in the first article approval of the vendor's facilities are being maintained.

Each certified vendor is required to request this re-certification from NAVSEA to maintain its first article qualification. The vendor's request shall be submitted to NAVSEA directly with a copy to all procuring activities where applicable. This request should be submitted at least 6 months prior to the need for re-certification.

At a minimum, the vendor's re-certification submittal shall include the following:

- a. A summary of the conformance test results (including alloy, maximum thickness of product as defined in the applicable appendix, mechanical properties, re-test results, and chemical composition) on qualified products produced since qualification or the previous re-certification including production product non-conformances and the associated cause(s) and corrective action(s).
- b. All production related facility changes on facilities used to produce the qualified product over the past 5 years.
- c. All Process Control Plan changes over the past 5 years which could affect the quality or performance of the product.
- d. The Change Control Plan used to adjudicate changes to the Process Control Plan and required related submittals for approval to NAVSEA by the vendor.

The re-certification process shall include a review of the vendor's submittal requesting re-certification. This may include a request for additional information or data and/or an audit of the facility to review current procedures and equipment, if deemed necessary. Based on the findings of these reviews additional first article testing may be required for approval of re-certification of the vendor's facility.

Upon successful completion of the re-certification, NAVSEA shall issue a re-certification letter. The certification must be current at the delivery date of procured products.

4.4 CONFORMANCE INSPECTION.

Conformance inspection shall consist of the examinations and tests specified in the applicable appendix.

4.4.1 Lot Definitions.

4.4.1.1 Lot for Chemical Composition. For chemical composition, a lot shall be defined as follows: ingot cast, each heat; continuous cast, each ladle; VAR or ESR, each remelted ingot; AOD, each vessel charge. Unless multiple ladle continuous casting was qualified by first article testing, continuous casting shall cease after one ladle of steel is completely cast.

4.4.1.2 Lot for Tension Tests. For tension tests, a lot shall be as defined in the applicable appendix.

4.4.1.3 Lot for Impact Tests. For Charpy V-notch and dynamic tear testing, a lot shall be as defined in the applicable appendix.

4.4.1.4 Lot for Examination and Inspections. For the purposes of visual, dimensional, and nondestructive examination, a lot shall be as defined in the applicable appendix.

4.4.2 Sampling.

4.4.2.1 Sampling for Examination. Specimens for examination shall be taken as specified in the applicable appendix.

4.4.2.2 Sampling for Chemical and Spectrographic Analysis. Specimens for chemical analysis shall be taken as specified in the applicable appendix.

4.4.2.3 Sampling for Tensile Test. Specimens for tensile test shall be taken as specified in the applicable appendix.

T9074-BD-GIB-010/0300 Rev 2

4.4.2.4 Sampling for Impact Test. Specimens for impact test, if required, shall be taken as specified in the applicable appendix.

4.4.2.5 Marking of Test Specimens. The test specimens shall be marked to ensure positive identification of the lot being tested.

4.4.3 Examination. All material shall be examined visually and dimensionally for conformance to the requirements of the applicable appendix. Additional examination shall be as specified in the applicable appendix.

4.5 TEST PROCEDURES.

4.5.1 Chemical or Spectrographic Analysis. Specimens shall be analyzed in accordance with a standard ASTM method or a method that will ensure equally accurate results for conformance to the chemical composition of the applicable appendix. The method(s) shall be correlated with National Institute of Standards and Technology standard reference materials, when available, to ensure the validity of the test method that is used as a control in chemical analysis or for calibration in instrumental methods of analysis. Additionally, the range over which the chemical analysis test methods can be shown to be accurate for the particular element reported shall be provided. The accuracy and precision of the chemical analysis method(s) used for each element being analyzed shall be provided (see 3.1).

4.5.2 Tensile Test. Tensile test specimens selected in accordance with the applicable appendix shall be tested in accordance with ASTM A370 and, for through-thickness testing of plate when required, ASTM A770. Specimens shall be 0.500-inch diameter standard round specimens per ASTM A370, or as specified in the applicable appendix, unless otherwise specified (see 6.2), except for castings, forgings, and bars. When dimensions of the product(s) preclude ASTM A370 standard round 0.500-inch (13-mm) specimens for castings, forgings, and bars, the largest round standard tensile specimens of ASTM A370 that can be obtained from the test material shall be used. If a product is to be aged or otherwise heat treated to reduce hydrogen, then the tensile test specimen(s) shall be removed from the plate, prolongation, or keel block after the hydrogen reduction heat treatment. Tensile specimens or specimen blanks shall not be aged or otherwise heat treated to reduce hydrogen.

4.5.3 Charpy V-Notch Impact Test. The test specimens shall be tested in accordance with ASTM A370 with coolant temperatures as specified in the applicable appendix. The notch shall be perpendicular to the nearest quenched and tempered surface and specimen location and orientation shall be as specified in the applicable appendix.

4.5.4 Dynamic Tear Impact Test. The test specimens shall be tested in accordance with ASTM E604. Coolant temperature shall be minus 40±3 °F (minus 40±2 °C) unless specified otherwise in the applicable appendix. The notch shall be perpendicular to the nearest quenched and tempered surface and specimen location and orientation shall be as specified in the applicable appendix.

4.5.5 Explosion Tests. The explosion tests, when required by the applicable appendix, shall be conducted using two explosion crack starter specimens fabricated in accordance with Appendix L. Unless specified otherwise in the applicable appendix, the tests shall be conducted at 0 °F (minus 18 °C). When required by the applicable appendix, the explosion bulge type test shall also be conducted in accordance with Appendix L and shall meet the requirements in the applicable appendix.

4.6 REJECTION AND RETESTS.

When a test specimen representing a lot of material fails to meet specification requirements, the lot shall be rejected. The Contractor may rework or retest the lot as provided (see 4.6.2 to 4.6.5 and applicable appendices) herein. The Contractor shall identify and separate rejected lots from acceptable lots until the rejected lots are withdrawn by the Contractor, or are demonstrated as meeting specification requirements. Only one (1) retest of a nonconforming original test is permitted, and the retest specimens shall be taken in the vicinity of the initial location of the failed specimen(s). If any retest specimen fails, the lot shall be rejected with no further testing permitted, except in cases where a lot consists of more than one item (see lot definitions in applicable appendices). When a lot with a rejected test specimen consists of more than one item and the applicable appendix does not provide other instructions, at the option of the Contractor, each item in the rejected lot may be tested for the failed test and each item that fails to meet the requirements of the applicable appendix shall be rejected. All test results, including failures, shall be reported, unless otherwise approved by NAVSEA in first article approval to accommodate automated data reporting systems. In all cases, all test results, including failures, shall be available for review upon request.

4.6.1 Reheat Treatment. The Contractor shall be permitted to reheat-treat material along with the representative prolongations or test blocks which fail to meet the tensile or impact requirements of the applicable appendix. Required tests at the same required test location as originally performed on the failed material shall be repeated when the material is re-inspected, except for the chemical analysis. On any additional heat treatment given, including austenitizing/quench and temper/quench, re-tempering/quench or hydrogen soak, all the new mechanical test specimens from the material, prolongation, or test block shall be taken from locations that meet the criteria from as quenched surfaces of the reheat treatment as specified in the applicable appendix.

4.6.2 Tensile Retest. If the results of an original tensile specimen fails to meet the requirements of the applicable appendix, but are within 1 kilopound per square inch (ksi) [6.9 Megapascals (MPa)] of the required yield strength, or within 2 percent of the required elongation, or within 2 percent of the required reduction-in-area, a retest on two additional specimens (selected from the same approximate location) shall be permitted.

4.6.2.1 Gauge Length Retest. If the percentage of elongation or reduction in area of an individual tensile specimen is less than that prescribed in the applicable appendix, and any part of the fracture is outside the gauge length, or within the gauge length and less than 25 percent of the gauge length from either datum point, another specimen from the same approximate location may be selected in its place.

4.6.3 Charpy V-Notch Retest. In the event that initial Charpy V-notch test results at a specified temperature do not meet the requirements of the applicable appendix, a retest of two additional sets of specimens (i.e., six specimens) from the same approximate location and at the same temperature shall be permitted on the same material. If the retest specimens do not meet the requirements (average and individual values), the lot represented by the specimens shall be rejected.

4.6.4 Dynamic Tear Retest. In the event that initial dynamic tear test results at a specified temperature do not meet the requirements of the applicable appendix, a retest of two additional sets of specimens (i.e., four specimens) from the same approximate location and at the same temperature shall be permitted on the same material. If any retest specimen does not meet the requirements, the lot represented by the specimens shall be rejected.

4.6.5 Defective Specimen/Replacement of Test Specimens. A test specimen shall be discarded and a replacement specimen selected from the same lot of the material under the following conditions:

- a. When the specimen is incorrectly machined.
- b. When the test procedure is incorrect.
- c. When there is a malfunction of the testing equipment.
- d. When a flaw that is not indicative of an inferior or defective lot of material is revealed during the test. However, internal flaws such as cracks, ruptures, and porosity are not reasons for the selection of a replacement test specimen.

T9074-BD-GIB-010/0300 Rev 2

THIS PAGE INTENTIONALLY LEFT BLANK

CHAPTER 5 PACKAGING

5.1 PREPARATION FOR PACKAGING AND PACKING.

Preparation for packaging and packing shall be as follows:

- a. Product(s) shall be clean and free of dirt, chips, or any other foreign matter.
- b. Contact preservative shall not be used.
- c. Product(s) shall be segregated as to heat number, composition, finish, and size.

5.2 PACKAGING, PACKING, AND MARKING FOR SHIPMENT.

Unless additional requirements are specified by the purchaser (see 6.2), material shall be prepared for shipment in accordance with commercial practice to ensure delivery of product in full compliance with this specification. The level of packaging and marking for shipment shall meet the requirements of carrier rules and regulations applicable to the mode of transportation.

5.3 PACKAGING BY DOD PERSONNEL.

When actual packaging of materiel is to be performed by DoD personnel, these personnel need to contact the responsible packaging activity to ascertain requisite packaging requirements. Packaging requirements are maintained by the Inventory Control Point's packaging activity within the Military Department or Defense Agency, or within the Military Department's System Command. Packaging data retrieval is available from the managing Military Department's or Defense Agency's automated packaging files, CD-ROM products, or by contacting the responsible packaging activity.

T9074-BD-GIB-010/0300 Rev 2

THIS PAGE INTENTIONALLY LEFT BLANK

CHAPTER 6 NOTES

6.1 INTENDED USE.

This specification is intended to provide the general requirements for acquisition of high-strength steels in various shapes and sizes as described in the applicable appendices.

6.2 ACQUISITION REQUIREMENTS.

Acquisition documents must specify the following, in addition to any additional requirements from the applicable appendix:

- a. Title, number, and date of this specification.
- b. Grade required (see 1.2).
- c. If required, the specific issue of individual documents referenced (see 2.2.1 and 2.3).
- d. When first article testing is not required (see 3.1).
- e. If virgin material is required (see 3.2).
- f. When a batch-type furnace working zone temperature survey shall be conducted with a typical, nominal, or simulated furnace load (see 3.5.3).
- g. Dimensions of non-standard tensile test specimens (see 4.5.2).
- h. Any special packaging requirements (see 5.2).

6.3 FIRST ARTICLE.

When a first article inspection is required, the item should be a first article sample. The first article should consist of one unit. The contracting officer should include specific instructions in acquisition documents regarding arrangements for examinations, approval of first article test results, and disposition of first articles. Invitations for bids should provide that the Government reserves the right to waive the requirement for samples for first inspection to those bidders offering a product that has been previously acquired or tested by the Government, and that bidders offering such products, who wish to rely on production or test, must furnish evidence with the bid that prior Government approval is presently appropriate for the pending contract.

6.3.1 New Vendors. Prior to delivery, manufacturers that have not previously produced products under this specification of the strength level specified should demonstrate to the Commander, Naval Sea Systems Command, Materials Division that their facilities produce products conforming to the requirements of this specification.

6.3.2 Forwarding Data. When a contract does not exist, first article data may be submitted directly to NAVSEA. The first article inspection data should be verified by the Defense Contract Management Agency (DCMA) or by the American Bureau of Shipping (ABS) representative. The report should be forwarded to the Commander, Naval Sea Systems Command, Materials Engineering Division via DCMA. Upon review of the report, authorization will be forwarded for preparation of test specimens for the explosion tests as required by Appendix L and instructions shall be furnished for shipment to designated Government testing locations. Specimen preparation and shipment will be under the cognizance of DCMA or ABS representatives, as applicable.

6.3.3 Manufacturing and Testing. The manufacture of the first article (e.g., rolling of plate or slabs, casting, forging billets, etc.), the laying out of test specimens, and the testing shall be witnessed by an ABS or DCMA representative.

6.3.4 Currently Qualified Vendors to Previous Specifications. Unless otherwise specified, first article testing for manufacturers currently qualified for the product forms covered by this specification shall consist of supplying data demonstrating attainment of the new requirements (first article and conformance) included in this specification based on data from current and future orders. No explosion testing is required. First article approval to the new requirements in this specification will cover section sizes up to and including the product form size from which acceptable first article test data is obtained.

T9074-BD-GIB-010/0300 Rev 2

THIS PAGE INTENTIONALLY LEFT BLANK

APPENDIX A (24645)

STEEL PLATE, SHEET, OR COIL, AGE-HARDENING ALLOY, STRUCTURAL, HIGH YIELD STRENGTH (HSLA-80 AND HSLA-100)

A.1 SCOPE.

A.1.1 Scope. This Appendix covers HSLA-80 and HSLA-100 high yield strength, age-hardening alloy steel plate, sheet, and coil intended primarily as replacements for steel Grades HY-80 and HY-100, respectively, for approved uses in critical structural applications where notch-tough, high-strength materials are required. The requirements apply to Grade HSLA-80 up to and including 1¼ inch (32 mm) thick and HSLA-100 up to 6 inches (152 mm) thick.

A.1.2 Classification. Steel plate, sheet, or coil covered by this specification shall be of the following types and grades as specified (see A.6.2).

- | | |
|----------------|---|
| Type I | - Plate, sheet, or coil for which ultrasonic testing for soundness and thickness is not performed. |
| Type II | - Plate over ½ inch (13 mm) in thickness for which ultrasonic testing for soundness and thickness is performed. Unless otherwise specified (see A.3.8 and A.6.2), each plate over ½ inch (13 mm) in thickness shall be classified as Type II. |
| Grade HSLA-80 | - 80,000 lb/in ² (80 ksi) [552 MPa] tensile yield strength, minimum. |
| Grade HSLA-100 | - 100,000 lb/in ² (100 ksi) [690 MPa] tensile yield strength, minimum for plate less than or equal to 4 inches (102 mm) thick. |
| Grade HSLA-100 | - 95,000 lb/in ² (95 ksi) [655 MPa] tensile yield strength, minimum for plate greater than 4 inches (102 mm) thick. |

A.2 APPLICABLE DOCUMENTS.

See Chapter 2.

A.3 REQUIREMENTS.

A.3.1 Material. The steel shall be vacuum degassed except for thicknesses of ⅜ inch (9.5 mm) or less, and very low sulfur, calcium treatment, or other NAVSEA-approved melt practices shall be used for sulfide inclusion shape control.

T9074-BD-GIB-010/0300 Rev 2

A.3.2 Chemical Composition. The chemical composition, heat, and product shall be as specified in [Table A-1](#).

Table A-1. Chemical Composition (Weight Percent). 1/

Element	Grade HSLA-80 ≤1¼ inch (32 mm)	Grade HSLA-100 ≤1 inch (25 mm) (Comp. 1)	Grade HSLA-100 ≤1⅝ inch (41 mm) (Comp. 2)	Grade HSLA-100 All Thicknesses (Comp. 3)
Carbon	0.06 2/			
Manganese	0.40 – 0.70	0.75 – 1.15	0.75 – 1.15	0.75 – 1.15
Phosphorus	0.020			
Sulfur	0.004 3/			
Silicon	0.40			
Nickel	0.70 – 1.00	1.50 – 2.00	2.45 – 3.00	3.35 – 3.65
Chromium	0.60 – 0.90	0.45 – 0.75	0.45 – 0.75	0.45 – 0.75
Molybdenum	0.15 – 0.25	0.30 – 0.55	0.45 – 0.60	0.55 – 0.65
Copper	1.00 – 1.30	1.00 – 1.30	1.00 – 1.30	1.15 – 1.75
Niobium (Columbium)	0.02 – 0.06			
Aluminum	4/			
Titanium	0.02			
Arsenic 6/	0.025			
Antimony 6/	0.025			
Vanadium	0.03			
Tin 6/	0.030			
Nitrogen	5/			

NOTES:

1/ Single values are maximum percentages. Except for carbon and sulfur, the chemical analysis tolerances as specified in ASTM A6 are to be applied to product (check) analysis. For elements not listed in ASTM A6, the product analysis shall not exceed the specified maximum.

2/ For HSLA-80 thickness ¾ inch and under, a maximum of 0.07 percent shall be permitted in heat analysis.

3/ The product analysis tolerance shall be 0.002 percent over the specified maximum.

4/ Minimum acid-soluble aluminum content of 0.010 percent or minimum total aluminum content of 0.015 percent for each ladle of each heat.

5/ For information only.

6/ Elements shall not be added intentionally.

A.3.3 **Tensile Properties.** The material shall meet the tensile property requirements as specified in [Table A-2](#) after all heat treatments.

Table A-2. Tensile Property Requirements.

	Grade HSLA-80		Grade HSLA-100	
	<¼ inch (6.4 mm)	≥¼ inch (6.4 mm)	≤1 inch (25 mm)	>1 inch (>25 mm)
Ultimate tensile strength (ksi)	<u>1/</u>			
Yield strength, 0.2 percent offset (ksi) [MPa]	80 – 110 <u>2/</u> [552 – 758]	80 – 100 <u>2/</u> [552 – 690]	100 – 120 [690 – 828]	100 – 120 [690 – 828] <u>3/</u>
Elongation in 2 inches, minimum (percent)	14	20	17 <u>4/</u>	18
Reduction in area, minimum, round specimen (percent)	<u>5/</u>	50 <u>5/</u>	<u>5/</u>	45 <u>6/</u>
NOTES:				
<p><u>1/</u> To be recorded for information only.</p> <p><u>2/</u> For HSLA-80 materials equal to or less than ½ inch (13 mm) in thickness, maximum yield strength shall be 110 ksi [759 MPa].</p> <p><u>3/</u> For HSLA-100 plate greater than 4 inches (102 mm) and less than or equal to 6 inches (152 mm) thick, the minimum yield strength shall be 95 ksi [655 MPa].</p> <p><u>4/</u> For HSLA-100 material less than ¼ inch (6.4 mm) in thickness, elongation shall be 12 percent, minimum.</p> <p><u>5/</u> A minimum percent reduction in area is not required for plate thicknesses equal to or less than ¾ inch (19 mm).</p> <p><u>6/</u> Through-thickness tensile testing is required for plate ≥3 inches (76 mm) thick (see A.4.3.1 and A.4.4.2.3). The only requirement is for reduction of area to be a minimum of 20 percent. There are no requirements for yield strength or elongation.</p>				

T9074-BD-GIB-010/0300 Rev 2

A.3.4 **Impact Properties.** The material shall meet the impact property requirements as specified in [Table A-3](#) after all heat treatments.

Table A-3. Impact Requirements, Charpy V-Notch, Transverse. 1/

Test (Coolant) Temperature, degrees	Minimum Average Energy, foot-pounds [joules] 2/		Minimum Shear Fracture, percent 3/	
	Grade HSLA-80 3/8 to 1 1/4 inches (9.5 to 32 mm) 4/	Grade HSLA-100 3/8 inch (9.5 mm) & over	Grade HSLA-80 3/8 to 1 1/4 inches (9.5 to 32 mm) 4/	Grade HSLA-100 3/8 inch (9.5 mm) & over
-120 °F, ±3 °F (-84 °C, ±2 °C)	105 [142]	60 [81]	50	50 3/
0 °F, ±3 °F (-18 °C, ±2 °C)	Not Required	80 [109]	Not Required	90

NOTES:

1/ Dynamic tear testing transverse to the final direction of plate rolling shall be performed at minus 40±3 °F on plate thicknesses over 5/8 inch (16 mm) and the results shall be recorded for information only.

2/ Average of three specimens. No single value shall be below the minimum average required by more than 5 ft-lbs, or equivalent fraction as designated by the appropriate standard sub-sized specimen, for the Charpy V-notch test.

3/ Measurement required on each Charpy V-notch specimen. No individual result shall be lower than the minimum. For HSLA-100 plate greater than 4 inches thick, the minimum percent shear fracture shall be 40 percent.

4/ For material thicknesses below 7/16 inch (11 mm), sub-sized Charpy V-notch test specimens shall be as specified in ASTM A673. Equivalent absorbed energy requirements for sub-sized specimens shall be as specified (see A.6.2).

A.3.5 **Heat Treatment.** Unless otherwise specified (see A.6.2), the Contractor shall determine the detailed procedure to produce products meeting the mechanical property requirements of this specification with the following restrictions:

- a. The heat treatment shall be as specified (see A.6.2) for treatment of Class 1 or Class 3 as follows:
 - (1) Class 1 - Controlled rolled and precipitation heat treated. This class is permissible only for HSLA-80 plate, sheet, or coil up to and including 1/2 inch (13 mm) in thickness, unless otherwise specifically approved by NAVSEA.
 - (2) Class 3 - Solution treated, quenched, and precipitation heat treated.
- b. The plate shall not be stress relieved.
- c. For all heat treatment operations, plates shall be positioned and supported in such a manner to prevent shifting or falling from their initial set positions during the heat treatment process. In addition, during precipitation heat treatment, plates shall be positioned in the furnace so that in a direct-fired furnace burner flames and hot gases from these flames cannot impinge upon plate surfaces and result in heating the plates above the maximum allowable precipitation heat treatment temperature. As a minimum, the plates shall be supported in the furnace in a manner that ensures that the plates cannot fall or shift outside of the furnace working zone and be exposed to burner flames or hot gases. Attention shall be given to ensure that the structure supporting the plate in the furnace, such as pylons, sawhorses, and racks, will not deflect flames and hot gases onto plate surfaces. The entire furnace load from the precipitation heat treatment for batch-type furnaces shall be taken from the furnace and quenched at the same time. Multiple quenching operations from the precipitation heat treatment batch-type furnace are strictly prohibited.
- d. In addition to the requirements of 3.5 for batch-type furnaces, the heat treatment record shall also include digital photographs and sketches providing sufficient accuracy to recreate positions and orientations of the plates in the furnace at future dates. The sketches shall identify every part in the load uniquely according to a vendor's internal tracking methodology. The sketches and photographs in the heat treatment record shall be of the furnace car plate-load immediately prior to entering the furnace for the precipitation heat treating cycle(s). Manufacturer Standard Practices shall be established, which shall include placement of plates, plate support structure (i.e., pylons, saw

horses, racks, etc.) on the furnace car, placement of the burners in the furnace, and the distances and orientations of the plates and support structure with respect to the burners. The verification of inspection record shall validate the plate was loaded in accordance with the sketches and photographs in the heat treatment record and the Manufacturer Standard Practices.

- e. The quench tank facility used to accomplish the solution heat treatment shall be of a sufficient capacity and design to provide multi-directional (from at least three directions or other effective design based on results of first article testing) water flow for effective quenching of the largest plates to be heat treated. The effectiveness of the quench tank facility in terms of capacity and water flow shall be demonstrated during first article testing. The maximum quench tank water temperature at the initiation of the quenching operation shall not exceed 80 °F. The mill shall put a process in place to maintain the effectiveness (e.g., flow rate and water capacity) of the quench tank similar to that used during the first article qualification.
- f. As an alternate to the thermal survey requirements of SAE AMS-H-6875, all furnaces that are used to heat-treat plates over ¼-inch (6.4-mm) gage may be thermally surveyed as follows:
 - (1) The initial survey is done once using the thinnest and thickest gage plate; the following surveys may use any gage.
 - (2) Furnaces must be surveyed every 6 months after the initial survey.
 - (3) Thermal surveys are conducted as follows:
 - (a) Three contact thermocouples must be used, one at each edge and one in the middle across the width of the plate.
 - (b) A calibrated recording device and thermocouples must be used.
 - (c) The test plate is run through the furnace using standard hold times.
 - (d) Trial starts when plate exits heat-up zones, and ends when plate exits furnace.
 - (e) Maximum temperature variability when plate is in soaking zones is ± 25 °F (± 14 °C).

A.3.5.1 Thermal Hydrogen Soak After Hot Rolling. All plate greater than 3 inches (76 mm) thick shall receive a post hot rolling soak using a procedure demonstrated to the requirements in A.4.3.1, unless otherwise approved by NAVSEA.

A.3.6 Surface Quality. The depth of rolled-in scale, pits, or other defects shall not exceed 0.015 inch (0.38 mm) and shall not result in an under gauge (less than minimum thickness) condition. Isolated, individual pits not over 0.030 inch (0.76 mm) deep or within 6 inches (152 mm) of each other will be acceptable, provided plate, sheet, or coil thickness is not reduced to an under gauge condition. Surface imperfections may be removed by grinding, provided the thickness is not reduced to an under gauge condition and the ground area is smoothly faired into surrounding metal.

A.3.6.1 Weld Repair of Mill Defects After Heat Treatment. Unless otherwise specified (see A.6.2), weld repair after final heat treatment shall be permitted. Mill imperfections may be repair-welded by the Contractor or referred to the contracting activity for acceptance with subsequent repair welding to be performed by the contracting activity. Areas of the plate, sheet, and coil found to have less than the minimum specified thickness may have the thickness restored by welding the depressed area. The following limitations shall apply to all weld repairs:

- a. The total area to be repaired shall not exceed 1 percent of the surface of one side of the plate, sheet, or coil.
- b. The depth of any area to be repaired shall not exceed one-half the minimum plate or coil thickness specified or ½ inch (13 mm), whichever is less. The depth of the area to be repaired shall be a minimum of ⅙ inch (1.6 mm).
- c. Areas within 2 inches (51 mm) of each other which require weld repair shall be combined to form a single repair.
- d. Areas to be welded shall be ground to assure that the welds are made on clean, sound metal.
- e. After preparation for repair and prior to welding, the depressed area shall be magnetic particle inspected in accordance with T9074-AS-GIB-010/271, and shall be free of relevant linear indications.
- f. Weld repairs shall be made in accordance with T9074-AD-GIB-010/1688, MIL-STD-1689, or the applicable fabrication document. Procedures and personnel shall be qualified in accordance with S9074-AQ-GIB-010/248.
- g. The final repaired surface shall be ground smooth and shall be essentially flush with the adjacent surface and free of undercut in excess of 0.020 inch (0.5 mm). No point of the finished weld surface shall be below the adjacent plate surface.

T9074-BD-GIB-010/0300 Rev 2

- h. Surface weld repairs shall be magnetic particle inspected after final grinding (or subsequent heat treatment, if applicable) in accordance with T9074-AS-GIB-010/271. Welds and ½ inch (13 mm) of adjacent base material shall be free of relevant linear indications greater than ⅛ inch (3.2 mm) in length.
- i. Repaired areas shall be marked. The markings shall remain legible and shall not be removed prior to performing all inspections specified herein.
- j. Notation of such repaired areas and the type of welding filler metal used to make the weld repair(s) shall be made on the plate inspection form as part of the records.
- k. If a non-heat treatable electrode is used, reheat treatment of the plate, sheet, or coil is prohibited.
- l. MIL-120S-1 and MIL-12018-M2 or equivalent strength welding consumables shall not be used for any welding including repair welding and weld build-up.
- m. MIL-11018-M electrodes shall not be used for any welding including repair welding and weld build-up. Weld repair and weld build-up shall be accomplished using MIL-10718-M or MIL-100S electrodes.

A.3.6.1.1 Weld Repairs of Mill Defects Prior to Heat Treatment. Weld repairs of mill imperfections may be accomplished prior to heat treatment within the limitations as specified in A.3.6.1, except such weld repairs shall be made using a NAVSEA approved heat treatable electrode.

A.3.6.2 Edge Defects. Visual laminar edge defects less than ¼ inch (6.4 mm) long shall be acceptable. Laminar edge defects ¼ inch (6.4 mm) long and over shall be explored by ultrasonic inspection on the surface adjacent to the affected area. Edge defects that extend into the material that will result in rejectable defects according to the ultrasonic acceptance standards specified (see A.3.8) shall be cause for rejection. Laminar edge defect weld repairs shall be made using a NAVSEA approved weld procedure.

A.3.7 Dimensional Tolerances. Tolerances shall be as specified in A.3.7.1 through A.3.7.6.

A.3.7.1 Tolerances for Material Less than ⅜ Inch (4.8 mm) in Thickness. For material less than ⅜ inch (4.8 mm) in thickness, the tolerances of ASTM A505 shall apply.

A.3.7.2 Alternate Dimensional Tolerances. Due to extensive past applications of HSLA-80/100 plate to the tolerances of ASTM A6, when specified (see A.6.2), HSLA-80/100 plate shall be ordered to the tolerances specified in ASTM A6. When plate is ordered to the dimensional tolerances in ASTM A6 and ordered by weight, the allowable under gauge at the edge of plates shall be as specified in [Table A-4](#).

A.3.7.3 Thickness, Weight, and Gauge. For plate ordered to decimal thickness over ⅜ inch (4.8 mm) and not ordered to ASTM A6, the maximum allowable variations in thickness measurements shall be as specified in [Table A-5](#) and [Table A-6](#). For plate ordered to a specific weight basis and not ordered to ASTM A6, the maximum allowable variations in weight and gauge shall be as specified in [Table A-4](#).

Table A-4. Allowable Variation in Weight and Gauge for Plates Specified on a Weight Basis (Applicable to Single Plates).

Allowable under gauge at edge for widths given, inches (mm)									
Specified weight, lb/ft ² [kg/m ²] {thickness, inch (mm)}	Up to 66 (1676), inclusive	Over 66 (1676) to 80 (2032), inclusive	Over 80 (2032) to 90 (2286), inclusive	Over 90 (2286) to 100 (2540), inclusive	Over 100 (2540) to 115 (2921), inclusive	Over 115 (2921) to 135 (3429), inclusive	Over 135 (3429) to 150 (3810), inclusive	Over 150 (3810) to 168 (4267), inclusive	Over 168 (4267)
	Percent	Percent	Percent	Percent	Percent	Percent	Percent	Percent	Percent
To 20.4 [100], exclusive {½ (13)}	6	6	8	8	8	8	8	8	8
20.4 [100] to 25.5 [125], exclusive {½ (13) to ⅝ (16)}	3.5	4	4.5	5	5.5	6.5	6.5	6.5	6.5
25.5 [125] to 30.6 [149], exclusive {⅝ (16) to ¾ (19)}	3.5	4	4.5	5	5.5	6	6	6	6
30.6 [149] to 40.8 [199], exclusive {¾ (19) to 1 (25)}	3	3	3.5	4	4	4.5	5	5.5	6
40.8 [199] and over {1 (25)}	3	3	3	3	3	3.5	4	4.5	5
Allowable weight tolerance for widths given, inches (mm)									
Specified weight, lb/ft ² [kg/m ²] {thickness, inch (mm)}	Up to 150 (3810), inclusive		Over 150 (3810) to 168 (4267), inclusive		Over 168 (4267)				
	Percent		Percent		Percent				
	Over	Under	Over	Under	Over	Under			
To 20.4 [100], exclusive {½ (13)}	8	10	---	---	---	---			
20.4 [100] to 25.5 [125], exclusive {½ (13) to ⅝ (16)}	2	4	---	---	---	---			
25.5 [125] to 30.6 [149], exclusive {⅝ (16) to ¾ (19)}	2	4	---	---	---	---			
30.6 [149] to 40.8 [199], exclusive {¾ (19) to 1 (25)}	2	3.5	3	4	3	4			
40.8 [199] and over {1 (25)}	2	3	2	3	3	4			

T9074-BD-GIB-010/0300 Rev 2

Table A-5. Thickness Tolerances in Inches and Millimeters (average) Over Ordered Thickness for Single Plate 2 Inches (51 mm) and Under in Thickness. 1/, 2/

Specified thickness, inches (mm)	Tolerance over ordered thickness for widths given, inch (mm)											
	48 (1219) or under	48 (1219) to 60 (1524), exclusive	60 (1524) to 72 (1829), exclusive	72 (1829) to 84 (2133), exclusive	84 (2133) to 96 (2438), exclusive	96 (2438) to 108 (2743), exclusive	108 (2743) to 120 (3048), exclusive	120 (3048) to 132 (3353), exclusive	132 (3353) to 144 (3658), exclusive	144 (3658) to 168 (4267), exclusive	168 (4267) to 182 (4623), exclusive	182 (4623) and over
¼ (6.4)	0.015 (0.4)	0.015 (0.4)	0.021 (0.5)	0.021 (0.5)	0.027 (0.7)	0.027 (0.7)	0.035 (0.9)	---	---	---	---	---
⅓ (7.9)	0.015 (0.4)	0.015 (0.4)	0.021 (0.5)	0.027 (0.7)	0.027 (0.7)	0.027 (0.7)	0.035 (0.9)	0.042 (1.1)	---	---	---	---
⅔ (9.5)	0.015 (0.4)	0.015 (0.4)	0.021 (0.5)	0.027 (0.7)	0.027 (0.7)	0.027 (0.7)	0.035 (0.9)	0.035 (0.9)	0.042 (1.1)	---	---	---
⅞ (11.1)	0.015 (0.4)	0.015 (0.4)	0.021 (0.5)	0.027 (0.7)	0.027 (0.7)	0.027 (0.7)	0.035 (0.9)	0.042 (1.1)	0.042 (1.1)	0.052 (1.3)	---	---
½ (12.7)	0.021 (0.5)	0.021 (0.5)	0.021 (0.5)	0.027 (0.7)	0.027 (0.7)	0.027 (0.7)	0.035 (0.9)	0.042 (1.1)	0.042 (1.1)	0.052 (1.3)	0.062 (1.6)	---
⅝ (14.3)	0.021 (0.5)	0.021 (0.5)	0.027 (0.7)	0.027 (0.7)	0.027 (0.7)	0.027 (0.7)	0.035 (0.9)	0.042 (1.1)	0.052 (1.3)	0.052 (1.3)	0.062 (1.6)	---
⅚ (15.9)	0.027 (0.7)	0.027 (0.7)	0.027 (0.7)	0.027 (0.7)	0.027 (0.7)	0.027 (0.7)	0.035 (0.9)	0.042 (1.1)	0.052 (1.3)	0.052 (1.3)	0.062 (1.6)	0.069 (1.8)
1⅙ (17.5)	0.027 (0.7)	0.027 (0.7)	0.027 (0.7)	0.027 (0.7)	0.027 (0.7)	0.027 (0.7)	0.035 (0.9)	0.042 (1.1)	0.052 (1.3)	0.052 (1.3)	0.062 (1.6)	0.069 (1.8)
1⅓ (19.1)	0.027 (0.7)	0.027 (0.7)	0.027 (0.7)	0.027 (0.7)	0.027 (0.7)	0.035 (0.9)	0.035 (0.9)	0.042 (1.1)	0.052 (1.3)	0.068 (1.7)	0.075 (1.9)	0.077 (2.0)
1⅔ (20.6)	0.027 (0.7)	0.035 (0.9)	0.035 (0.9)	0.035 (0.9)	0.035 (0.9)	0.035 (0.9)	0.042 (1.1)	0.052 (1.3)	0.052 (1.3)	0.068 (1.7)	0.075 (1.9)	0.085 (2.2)
1⅚ (22.2)	0.035 (0.9)	0.035 (0.9)	0.035 (0.9)	0.035 (0.9)	0.035 (0.9)	0.042 (1.1)	0.042 (1.1)	0.052 (1.3)	0.062 (1.6)	0.068 (1.7)	0.075 (1.9)	0.085 (2.2)
1⅞ (23.8)	0.035 (0.9)	0.035 (0.9)	0.035 (0.9)	0.035 (0.9)	0.035 (0.9)	0.042 (1.1)	0.042 (1.1)	0.052 (1.3)	0.062 (1.6)	0.075 (1.9)	0.085 (2.2)	0.093 (2.4)
1 (25.4)	0.035 (0.9)	0.035 (0.9)	0.042 (1.1)	0.042 (1.1)	0.042 (1.1)	0.042 (1.1)	0.042 (1.1)	0.052 (1.3)	0.062 (1.6)	0.075 (1.9)	0.085 (2.2)	0.093 (2.4)
1⅙ (27.0)	0.035 (0.9)	0.035 (0.9)	0.042 (1.1)	0.042 (1.1)	0.042 (1.1)	0.042 (1.1)	0.052 (1.3)	0.052 (1.3)	0.062 (1.6)	0.075 (1.9)	0.085 (2.2)	0.096 (2.4)
1⅓ (28.6)	0.042 (1.1)	0.042 (1.1)	0.042 (1.1)	0.042 (1.1)	0.042 (1.1)	0.042 (1.1)	0.052 (1.3)	0.052 (1.3)	0.068 (1.7)	0.075 (1.9)	0.085 (2.2)	0.096 (2.4)
1⅔ (30.2)	0.042 (1.1)	0.042 (1.1)	0.052 (1.3)	0.052 (1.3)	0.052 (1.3)	0.052 (1.3)	0.052 (1.3)	0.062 (1.6)	0.075 (1.9)	0.085 (2.2)	0.095 (2.4)	0.102 (2.6)
1⅚ (31.8)	0.042 (1.1)	0.042 (1.1)	0.052 (1.3)	0.052 (1.3)	0.052 (1.3)	0.052 (1.3)	0.062 (1.6)	0.062 (1.6)	0.075 (1.9)	0.085 (2.2)	0.095 (2.4)	0.106 (2.7)
1⅞ (33.3)	0.042 (1.1)	0.042 (1.1)	0.052 (1.3)	0.052 (1.3)	0.052 (1.3)	0.052 (1.3)	0.062 (1.6)	0.062 (1.6)	0.075 (1.9)	0.095 (2.4)	0.105 (2.7)	0.115 (2.9)
1⅞ (34.9)	0.047 (1.2)	0.052 (1.3)	0.052 (1.3)	0.052 (1.3)	0.052 (1.3)	0.052 (1.3)	0.062 (1.6)	0.068 (1.7)	0.085 (2.2)	0.095 (2.4)	0.105 (2.7)	0.115 (2.9)
1⅞ (36.5)	0.047 (1.2)	0.052 (1.3)	0.062 (1.6)	0.062 (1.6)	0.062 (1.6)	0.062 (1.6)	0.062 (1.6)	0.075 (1.9)	0.085 (2.2)	0.105 (2.7)	0.115 (2.9)	0.125 (3.2)
1⅞ (38.1)	0.052 (1.3)	0.052 (1.3)	0.062 (1.6)	0.062 (1.6)	0.062 (1.6)	0.062 (1.6)	0.068 (1.7)	0.075 (1.9)	0.085 (2.2)	0.105 (2.7)	0.115 (2.9)	0.125 (3.2)
1⅞ (39.7)	0.052 (1.3)	0.052 (1.3)	0.062 (1.6)	0.062 (1.6)	0.062 (1.6)	0.062 (1.6)	0.068 (1.7)	0.075 (1.9)	0.095 (2.4)	0.105 (2.7)	0.130 (3.3)	0.145 (3.7)
1⅞ (41.3)	0.062 (1.6)	0.062 (1.6)	0.062 (1.6)	0.062 (1.6)	0.062 (1.6)	0.062 (1.6)	0.075 (1.9)	0.085 (2.2)	0.095 (2.4)	0.115 (2.9)	0.130 (3.3)	0.145 (3.7)
1⅞ (42.9)	0.062 (1.6)	0.062 (1.6)	0.068 (1.7)	0.068 (1.7)	0.068 (1.7)	0.068 (1.7)	0.075 (1.9)	0.085 (2.2)	0.105 (2.7)	0.115 (2.9)	0.130 (3.3)	0.145 (3.7)
1⅞ (44.5)	0.062 (1.6)	0.062 (1.6)	0.068 (1.7)	0.068 (1.7)	0.068 (1.7)	0.068 (1.7)	0.075 (1.9)	0.085 (2.2)	0.105 (2.7)	0.125 (3.2)	0.145 (3.7)	0.165 (4.2)
1⅞ (46.0)	0.062 (1.6)	0.062 (1.6)	0.075 (1.9)	0.075 (1.9)	0.075 (1.9)	0.075 (1.9)	0.085 (2.2)	0.095 (2.4)	0.105 (2.7)	0.125 (3.2)	0.145 (3.7)	0.165 (4.2)
1⅞ (47.6)	0.062 (1.6)	0.062 (1.6)	0.075 (1.9)	0.075 (1.9)	0.075 (1.9)	0.075 (1.9)	0.085 (2.2)	0.095 (2.4)	0.115 (2.9)	0.125 (3.2)	0.145 (3.7)	0.165 (4.2)
1⅞ (49.2)	0.068 (1.7)	0.068 (1.7)	0.075 (1.9)	0.075 (1.9)	0.075 (1.9)	0.075 (1.9)	0.085 (2.2)	0.095 (2.4)	0.115 (2.9)	0.141 (3.6)	0.157 (4.0)	0.174 (4.4)
2 (50.8)	0.068 (1.7)	0.068 (1.7)	0.075 (1.9)	0.075 (1.9)	0.075 (1.9)	0.075 (1.9)	0.085 (2.2)	0.095 (2.4)	0.115 (2.9)	0.141 (3.6)	0.157 (4.0)	0.174 (4.4)

NOTES:

1/ Tolerance under specified thickness, 0.01 inch (0.3 mm).2/ For intermediate thickness the tolerance of the closer specified gauge shall apply. In case of mid-point, the tolerance for the lower gauge or interpolated value shall apply.

Table A-6. Thickness Tolerances in Inches (mm) (Average) Over Ordered Thickness for a Single Plate Over 2 Inches (51 mm) Thick When Ordered to Thickness in Inches (mm). 1/ 2/

Specified thickness, inches (mm)	Tolerances over specified thickness for widths given, inch (mm)					
	To 36 (914), exclusive	36 (914) to 60 (1524), exclusive	60 (1524) to 84 (2134), exclusive	84 (2134) to 120 (3048), exclusive	120 (3048) to 132 (3353), exclusive	132 (3353) and over
Over 2 (50.8) to 3 (76.2), exclusive	0.063 (1.6)	0.094 (2.4)	0.109 (2.8)	0.125 (3.2)	0.125 (3.2)	0.141 (3.6)
3 (76.2) to 4 (101.6), exclusive	0.078 (2.0)	0.094 (2.4)	0.109 (2.8)	0.125 (3.2)	0.125 (3.2)	0.141 (3.6)
4 (101.6) to 6 (152.4), exclusive	0.094 (2.4)	0.125 (3.2)	0.141 (3.6)	0.156 (4.0)	0.156 (4.0)	0.172 (4.4)
6 (152.4)	0.109 (2.8)	0.125 (3.2)	0.156 (4.0)	0.172 (4.4)	0.172 (4.4)	----
NOTES:						
<u>1/</u> Tolerance under specified thickness, 0.01 inch (0.3 mm).						
<u>2/</u> For intermediate thickness, the tolerance of the closer gauge shall apply. In case of mid-point, the tolerance for the lower gauge or interpolated value shall apply.						

T9074-BD-GIB-010/0300 Rev 2

A.3.7.4 Flatness. Plates over $\frac{3}{16}$ inch (4.8 mm) thick not ordered to ASTM A6 shall be flat within the tolerance limits specified in [Table A-7](#). The flatness, as specified in [Table A-7](#), shall be an overall flatness factor. This factor shall not apply to “kinks” or “waviness”. The waviness or kinking permitted shall be judged by laying a 3-foot (1-meter) straightedge across the affected edges. The maximum permissible deviation from the straightedge shall be $\frac{1}{4}$ inch (6.4 mm). When specified (see A.6.2), tighter requirements may be required.

A.3.7.5 Camber. Camber of the plates over $\frac{3}{16}$ inch (4.8 mm) thick not ordered to ASTM A6 shall not exceed the tolerance limits specified in [Table A-8](#).

A.3.7.6 Size Tolerances. The width and length of the plates over $\frac{3}{16}$ inch (4.8 mm) thick not ordered to ASTM A6 shall not vary in excess of the tolerances specified in [Table A-9](#) and [Table A-10](#).

Table A-7. Flatness Tolerances for Plates Ordered on a lb/ft² [kg/m²] or Inch (mm) Basis. 1/, 2/, 3/

Specified thickness, inches (mm)	Specified weight, lb/ft ² [kg/m ²]	Flatness tolerance for specified widths, inches (mm)										
		Up to 36 (914), exclusive	36 (914) to 48 (1219), exclusive	48 (1219) to 60 (1524), exclusive	60 (1524) to 72 (1829), exclusive	72 (1829) to 84 (2134), exclusive	84 (2134) to 96 (2438), exclusive	96 (2438) to 108 (2743), exclusive	108 (2743) to 120 (3048), exclusive	120 (3048) to 144 (3658), exclusive	144 (3658) to 168 (4267), exclusive	168 (4267) and over
To ¼ (6), exclusive	To 10.2 [49.8], exclusive	¹³ / ₁₆ (21)	1 ¹ / ₈ (29)	1 ³ / ₈ (35)	1 ⁷ / ₈ (48)	2 (51)	2¼ (57)	2 ³ / ₈ (60)	2 ⁵ / ₈ (67)	2¾ (70)	---	---
¼ (6) to ³ / ₈ (10), exclusive	10.2 [49.8] to 15.3 [74.7], exclusive	³ / ₄ (19)	¹⁵ / ₁₆ (24)	1 ¹ / ₈ (29)	1 ³ / ₈ (35)	1¾ (45)	1 ⁷ / ₈ (48)	2 (51)	2¼ (57)	2 ³ / ₈ (60)	---	---
³ / ₈ (10) to ½ (13), exclusive	15.3 [74.7] to 20.4 [99.6], exclusive	³ / ₄ (19)	⁷ / ₈ (22)	¹⁵ / ₁₆ (24)	¹⁵ / ₁₆ (24)	1 ¹ / ₈ (29)	1 ⁵ / ₁₆ (33)	1½ (38)	1 ⁵ / ₈ (41)	1 ⁷ / ₈ (48)	2¾ (70)	3 ¹ / ₈ (79)
½ (13) to ¾ (19), exclusive	20.4 [99.6] to 30.6 [149.4], exclusive	⁵ / ₈ (16)	³ / ₄ (19)	¹³ / ₁₆ (21)	⁷ / ₈ (22)	1 (25)	1 ¹ / ₈ (29)	1¼ (32)	1 ³ / ₈ (35)	1 ⁵ / ₈ (41)	2¼ (57)	3 (76)
¾ (19) to 1 (25), exclusive	30.6 [149.4] to 40.8 [199.2], exclusive	⁵ / ₈ (16)	³ / ₄ (19)	⁷ / ₈ (22)	⁷ / ₈ (22)	¹⁵ / ₁₆ (24)	1 (25)	1 ¹ / ₈ (29)	1 ⁵ / ₁₆ (33)	1½ (38)	2 (51)	2 ⁵ / ₈ (67)
1 (25) to 2 (51), exclusive	40.8 [199.2] to 81.6 [398.4], exclusive	⁹ / ₁₆ (14)	⁵ / ₈ (16)	³ / ₄ (19)	¹³ / ₁₆ (21)	⁷ / ₈ (22)	¹⁵ / ₁₆ (24)	1 (25)	1 (25)	1 (25)	1 ⁵ / ₈ (41)	2¼ (57)
2 (51) to 4 (102), exclusive	81.6 [398.4] to 163.2 [797], exclusive	½ (13)	⁹ / ₁₆ (14)	¹¹ / ₁₆ (18)	³ / ₄ (19)	³ / ₄ (19)	³ / ₄ (19)	³ / ₄ (19)	⁷ / ₈ (22)	1 (25)	1¼ (32)	1 ⁵ / ₈ (41)
4 (102) to 6 (152), exclusive	163.2 [797] to 244.8 [1195], exclusive	⁹ / ₁₆ (14)	¹¹ / ₁₆ (18)	³ / ₄ (19)	³ / ₄ (19)	⁷ / ₈ (22)	⁷ / ₈ (22)	¹⁵ / ₁₆ (24)	1 ¹ / ₈ (29)	1¼ (32)	1¼ (32)	1½ (38)
6 (152)	244.8 [1195]	⁵ / ₈ (16)	³ / ₄ (19)	³ / ₄ (19)	¹⁵ / ₁₆ (24)	1 (25)	1 ¹ / ₈ (29)	1¼ (32)	1 ⁵ / ₁₆ (33)	1½ (38)	1½ (38)	1½ (38)

NOTES:

1/ Flatness tolerances for length and width. The longer dimension specified is considered the length. Variation from a flat surface along the length shall not exceed the tabular amount for the specified width in any 12 feet (4 meters) of length.

2/ When the longer dimension is under 36 inches (1 meter), the variation in flatness shall not exceed ¼ inch (6.4 mm).

3/ The above table and notes also cover the flatness tolerances of circular and sketch plates, based on the maximum dimensions of those plates.

T9074-BD-GIB-010/0300 Rev 2

Table A-8. Camber Tolerances for Plates Ordered on a lb/ft² [kg/m²] or Inch (mm) Basis.

Specified weight, lb/ft ² [kg/m ²]	Thickness, inches (mm)	Width, inches (mm)	Camber tolerance for thickness and width given		
To 81.6 [398], inclusive	To 2 (51), inclusive	All	1/8 inch	X	<u>length (feet)</u> 5
			3 mm	X	<u>length (meters)</u> 1.524
----	Over 2 (51) to 6 (152), inclusive	To 30 (762), inclusive	3/16 inch	X	<u>length (feet)</u> 5
			5 mm	X	<u>length (meters)</u> 1.524
----	Over 2 (51) to 6 (152), inclusive	Over 30 (762) to 60 (1524), inclusive	1/4 inch	X	<u>length (feet)</u> 5
			6.4 mm	X	<u>length (meters)</u> 1.524

Table A-9. Width and Length Tolerances for Sheared Plates 1 Inch (25 mm) Thick or Less. 1/

Specified dimensions, inches (mm)		Maximum permissible variations over specific width and length for weight or thickness given.					
Width	Length	To $\frac{3}{8}$ inch (10 mm), exclusive		$\frac{3}{8}$ to $\frac{5}{8}$ inch (10 to 16 mm), exclusive		$\frac{5}{8}$ to 1 inch (16 to 25 mm), exclusive	
		Under 15.3 lb/ft ² [74.7 kg/m ²], exclusive		15.3 to 25.5 lb/ft ² [74.7 to 124.6 kg/m ²], exclusive		25.5 to 40.8 lb/ft ² [124.6 to 199.4 kg/m ²], exclusive	
		Width, inch (mm)	Length, inch (mm)	Width, inch (mm)	Length, inch (mm)	Width, inch (mm)	Length, inch (mm)
To 60 (1524), exclusive	To 120 (3048), exclusive	$\frac{3}{8}$ (10)	$\frac{1}{2}$ (13)	$\frac{7}{16}$ (11)	$\frac{5}{8}$ (16)	$\frac{1}{2}$ (13)	$\frac{3}{4}$ (19)
60 (1524) to 84 (2134), exclusive		$\frac{7}{16}$ (11)	$\frac{5}{8}$ (16)	$\frac{1}{2}$ (13)	$\frac{11}{16}$ (18)	$\frac{5}{8}$ (16)	$\frac{7}{8}$ (22)
84 (2134) to 108 (2743), exclusive		$\frac{1}{2}$ (13)	$\frac{3}{4}$ (19)	$\frac{5}{8}$ (16)	$\frac{7}{8}$ (22)	$\frac{3}{4}$ (19)	1 (25)
108 (2743) and over		$\frac{5}{8}$ (16)	$\frac{7}{8}$ (22)	$\frac{3}{4}$ (19)	1 (25)	$\frac{7}{8}$ (22)	$1\frac{1}{8}$ (29)
To 60 (1524), exclusive	120 (3048) to 240 (6096), exclusive	$\frac{3}{8}$ (10)	$\frac{3}{4}$ (19)	$\frac{1}{2}$ (13)	$\frac{7}{8}$ (22)	$\frac{5}{8}$ (16)	1 (25)
60 (1524) to 84 (2134), exclusive		$\frac{1}{2}$ (13)	$\frac{3}{4}$ (19)	$\frac{5}{8}$ (16)	$\frac{7}{8}$ (22)	$\frac{3}{4}$ (19)	1 (25)
84 (2134) to 108 (2743), exclusive		$\frac{9}{16}$ (14)	$\frac{7}{8}$ (22)	$\frac{11}{16}$ (18)	$\frac{15}{16}$ (24)	$\frac{13}{16}$ (21)	$1\frac{1}{8}$ (29)
108 (2743) and over		$\frac{5}{8}$ (16)	1 (25)	$\frac{3}{4}$ (19)	$1\frac{3}{16}$ (30)	$\frac{7}{8}$ (22)	$1\frac{1}{4}$ (32)
To 60 (1524), exclusive	240 (6096) to 360 (9144), exclusive	$\frac{3}{8}$ (10)	$1\frac{1}{16}$ (27)	$\frac{1}{2}$ (13)	$1\frac{3}{16}$ (30)	$\frac{5}{8}$ (16)	$1\frac{5}{16}$ (33)
60 (1524) to 84 (2134), exclusive		$\frac{1}{2}$ (13)	$1\frac{1}{16}$ (27)	$\frac{5}{8}$ (16)	$1\frac{3}{16}$ (30)	$\frac{3}{4}$ (19)	$1\frac{5}{16}$ (33)
84 (2134) to 108 (2743), exclusive		$\frac{9}{16}$ (14)	$1\frac{1}{16}$ (27)	$\frac{11}{16}$ (18)	$1\frac{3}{16}$ (30)	$\frac{7}{8}$ (22)	$1\frac{7}{16}$ (37)
108 (2743) and over		$\frac{11}{16}$ (18)	$1\frac{3}{16}$ (30)	$\frac{7}{8}$ (22)	$1\frac{5}{16}$ (33)	1 (25)	$1\frac{7}{16}$ (37)
To 60 (1524), exclusive	360 (9144) to 480 (12192), exclusive	$\frac{7}{16}$ (11)	$1\frac{3}{16}$ (30)	$\frac{1}{2}$ (13)	$1\frac{5}{16}$ (33)	$\frac{5}{8}$ (16)	$1\frac{7}{16}$ (37)
60 (1524) to 84 (2134), exclusive		$\frac{1}{2}$ (13)	$1\frac{5}{16}$ (33)	$\frac{5}{8}$ (16)	$1\frac{7}{16}$ (37)	$\frac{3}{4}$ (19)	$1\frac{9}{16}$ (40)
84 (2134) to 108 (2743), exclusive		$\frac{9}{16}$ (14)	$1\frac{5}{16}$ (33)	$\frac{3}{4}$ (19)	$1\frac{7}{16}$ (37)	$\frac{7}{8}$ (22)	$1\frac{9}{16}$ (40)
108 (2743) and over		$\frac{3}{4}$ (19)	$1\frac{7}{16}$ (37)	$\frac{7}{8}$ (22)	$1\frac{9}{16}$ (40)	1 (25)	$1\frac{11}{16}$ (43)
To 60 (1524), exclusive	480 (12192) to 600 (15240), exclusive	$\frac{7}{16}$ (11)	$1\frac{3}{8}$ (35)	$\frac{1}{2}$ (13)	$1\frac{5}{8}$ (41)	$\frac{5}{8}$ (16)	$1\frac{3}{4}$ (45)
60 (1524) to 84 (2134), exclusive		$\frac{1}{2}$ (13)	$1\frac{1}{2}$ (38)	$\frac{5}{8}$ (16)	$1\frac{5}{8}$ (41)	$\frac{3}{4}$ (19)	$1\frac{3}{4}$ (45)
84 (2134) to 108 (2743), exclusive		$\frac{5}{8}$ (16)	$1\frac{1}{2}$ (38)	$\frac{3}{4}$ (19)	$1\frac{5}{8}$ (41)	$\frac{7}{8}$ (22)	$1\frac{3}{4}$ (45)
108 (2743) and over		$\frac{3}{4}$ (19)	$1\frac{5}{8}$ (41)	$\frac{7}{8}$ (22)	$1\frac{3}{4}$ (45)	1 (25)	$1\frac{7}{8}$ (48)
To 60 (1524), exclusive	600 (15240) to 720 (18288), exclusive	$\frac{1}{2}$ (13)	$1\frac{7}{8}$ (48)	$\frac{5}{8}$ (16)	2 (51)	$\frac{3}{4}$ (19)	2 (51)
60 (1524) to 84 (2134), exclusive		$\frac{5}{8}$ (16)	$1\frac{7}{8}$ (48)	$\frac{3}{4}$ (19)	2 (51)	$\frac{7}{8}$ (22)	2 (51)
84 (2134) to 108 (2743), exclusive		$\frac{5}{8}$ (16)	$1\frac{7}{8}$ (48)	$\frac{3}{4}$ (19)	2 (51)	$\frac{7}{8}$ (22)	2 (51)
108 (2743) and over		$\frac{7}{8}$ (22)	$1\frac{7}{8}$ (48)	1 (25)	$2\frac{1}{8}$ (54)	$1\frac{1}{8}$ (29)	$2\frac{3}{8}$ (60)
To 60 (1524), exclusive	720 (18288) and over	$\frac{9}{16}$ (14)	$2\frac{1}{8}$ (54)	$\frac{3}{4}$ (19)	$2\frac{1}{4}$ (57)	$\frac{7}{8}$ (22)	$2\frac{3}{8}$ (60)
60 (1524) to 84 (2134), exclusive		$\frac{3}{4}$ (19)	$2\frac{1}{8}$ (54)	$\frac{7}{8}$ (22)	$2\frac{1}{4}$ (57)	1 (25)	$2\frac{3}{8}$ (60)
84 (2134) to 108 (2743), exclusive		$\frac{3}{4}$ (19)	$2\frac{1}{8}$ (54)	$\frac{7}{8}$ (22)	$2\frac{1}{4}$ (57)	1 (25)	$2\frac{3}{8}$ (60)
108 (2743) and over		1 (25)	$2\frac{1}{8}$ (54)	$1\frac{1}{8}$ (29)	$2\frac{1}{2}$ (64)	$1\frac{1}{4}$ (32)	$2\frac{5}{8}$ (67)

NOTES:

1/ Maximum permissible variation under specified width and length, $\frac{1}{4}$ inch (6.4 mm).

Table A-10. Width and Length Tolerances for Gas-Cut Rectangular Plates. 1/

Specified thicknesses, inches (mm)	Tolerances over for all specified widths or lengths, inches (mm)
To 2 (51), exclusive	$\frac{3}{4}$ (19)
2 (51) to 4 (102), exclusive	1 (25)
4 (102) to 6 (152), exclusive	$1\frac{1}{8}$ (29)
6 (152)	$1\frac{5}{16}$ (33)
NOTES: <u>1</u> / Maximum permissible variation under specified width and length is $\frac{1}{4}$ inch (6.4 mm).	

A.3.8 Internal Soundness and Thickness. Plates over ½ inch (13 mm) thick, unless otherwise specified (see A.6.2), shall be ultrasonically inspected for internal soundness in accordance with A.4.6.5.1 and ultrasonically measured for decimal thickness in accordance with A.4.6.5.2. Each Type II plate, and, when specified (see A.6.2), all plates, shall be ultrasonically inspected for internal soundness and ultrasonically measured for decimal thickness. Plates over ½ inch (13 mm) thick not ultrasonically inspected or ultrasonically measured for decimal thickness shall be classified as Type I in accordance with A.1.2.

A.3.8.1 Recording of Thickness Measurements and Internal Soundness Results. Thickness measurements, mechanical and, where applicable, ultrasonic (see A.4.6.5.2), shall be prepared in accordance with the format shown on [Figure J-1](#). When internal soundness inspection is performed (see A.3.8), results shall be prepared in accordance with the format shown on [Figure A-5](#).

A.3.9 Applicable Fabrication Document. If applicable, the fabrication document shall be specified (see A.6.2) and shall cover the repair and the inspection of the base metal.

A.3.10 Cleaning and Preservation of Plate, Sheet, or Coil Surfaces. Unless otherwise specified (see A.6.2), the surface of the plate, sheet, or coil shall be descaled and coated as specified (see A.6.2 and Appendix K).

A.3.11 Marking. Each plate, sheet, or coil shall be indentation stamped with heat number, plate number, type number, class number, grade, and the designation HSLA-80 or HSLA-100. The primary (final) rolling direction of the plate with respect to the hot top of the ingot shall be identified. Where the plate, sheet, or coil number provides positive identification of any required numbers, the numbers may be omitted from the markings. When the plates, sheets, or coils are cut into smaller sizes for delivery, each piece shall be marked with the required data. The marking may be painted or stenciled in lieu of die stamped on material ¼ inch (6.4 mm) and less. Indentation stamping shall be done with a round-nosed die.

A.3.12 Explosion Testing. Explosion testing is required as part of first article testing and is not required for conformance testing. Two explosion crack starter tests are required for first article testing. Both specimens shall conform to the crack starter configuration requirements on [Figure L-8](#) and meet the explosion crack starter requirements in Appendix L. When explosion bulge type testing is specified (see A.6.2), testing shall be in accordance with Appendix L and additional bulge test shots shall continue until a minimum reduction in thickness of 16 percent for HSLA-80 or 14 percent for HSLA-100 is obtained on one or both sides.

A.3.13 Drop Weight Nil-Ductility Test. The specimen shall exhibit “no break” condition at minus 90±3 °F (minus 68±2 °C) for HSLA-80 and at the temperature specified for HSLA-100 (see A.6.2).

A.4 VERIFICATION.

A.4.1 Responsibility for Inspection. (See 4.1.)

A.4.2 Classification of Inspections. The inspection requirements specified herein are classified as follows:

- a. First article inspection (see A.4.3).
- b. Conformance inspection (see A.4.4).

A.4.3 First Article Inspection. First article inspection shall consist of the examinations and tests specified in [Table A-11](#) (see 4.3 and 6.3 and Appendix L). A first article inspection report shall be prepared as specified in 3.1. In addition, as part of the Process Control Plan (see 4.3.2), the manufacturer shall identify the maximum Pcm carbon equivalent (CE) and the minimum IIW CE values that will be used during production to provide enhanced resistance to hydrogen-assisted heat affected zone cracking and reasonable assurance of meeting minimum yield strength, respectively. These values shall be based upon available laboratory and production data and shall be reflected in the material submitted for first article testing. The formulas for determining each CE are as follows:

$$\text{Pcm CE (wt\%)} = \%C + \frac{\%Si}{30} + \frac{\%Mn + \%Cu + \%Cr}{20} + \frac{\%Ni}{60} + \frac{\%Mo}{15} + \frac{\%V}{10} + \%B \quad 5$$

$$\text{IIW CE (wt\%)} = \%C + \frac{\%Mn}{6} + \frac{\%Cu + \%Ni}{15} + \frac{\%Cr + \%Mo + \%V}{5}$$

A.4.3.1 Sampling for First Article Inspection. Specimens for first article testing shall be located and tested as specified on [Figure A-1](#) and [Figure A-2](#), unless otherwise specified (see A.6.2). As a minimum, for HSLA-80 plate thicknesses of 1 inch (25 mm) and the thickest and thinnest gauges to be produced are required to be produced and tested. As a minimum, for HSLA-100 plate thicknesses of 1 inch (25 mm), 1½ inch (41 mm), or 2 inches (51 mm), and the thickest gauge to be produced at the mill shall be produced and tested depending on the chemical composition being qualified. HSLA-80 and each individual chemical composition type of HSLA-100 shall be tested separately.

Table A-11. First Article and Conformance Inspection Requirements.

Examination and Tests	Requirement	Test Method	First Article	Conformance
Chemical analysis	A.3.2	4.5.1 and A.4.6.1	X	X
Tensile properties	A.3.3	4.5.2 and A.4.6.2	X	X
Explosion	A.3.12	4.5.5 and A.4.6.6	X	---
Microstructure analysis	---	A.4.6.7	X	---
Impact Properties				
Charpy V-notch	A.3.4	4.5.3 and A.4.6.3.1	X	X
Dynamic tear	A.3.4	4.5.4 and A.4.6.3.2	X	X
Drop weight nil-ductility	A.3.13	A.4.6.3.3	X	---
Examinations				
Surface quality	A.3.6	A.4.5	X	X
Dimensional	A.3.7	A.4.6.4	X	X
Internal soundness	A.3.8	A.4.6.4	X	X

A.4.4 Conformance Inspection. Conformance inspection (i.e., inspections of production lots) shall consist of the examinations and tests specified in [Table A-11](#).

A.4.4.1 Lot Definitions.

A.4.4.1.1 Lot for Chemical Analysis. See 4.4.1.1.

A.4.4.1.2 Lot for Tension Tests. Each plate, sheet, or coil as-heat-treated shall constitute a lot.

A.4.4.1.3 Lot for Impact Tests. Each plate, sheet, or coil as-heat-treated shall constitute a lot.

A.4.4.1.4 Lot for Examination and Inspections. For purposes of visual and dimensional examination and for nondestructive inspection, each plate, sheet, or coil prepared for final inspection shall constitute a lot.

A.4.4.2 Sampling for Conformance Inspection.

A.4.4.2.1 Location of Test Specimens in Plate, Sheet, or Coil. The specimens shall be located as shown on [Figure A-3](#) and [Figure A-4](#). [Figure A-3](#) shall be used when the final direction of rolling is parallel to the longitudinal axis of the ingot. [Figure A-4](#) shall be used when the final rolling direction is parallel to the transverse axis of the ingot. The final direction of rolling is the direction of rolling in which the greatest reduction ratio was achieved.

A.4.4.2.2 Sampling for Chemical or Spectrographic Analysis. Solid specimens for chemical or spectrographic analysis shall be taken from mid-thickness at the top center position (see [Figure A-3](#) and [Figure A-4](#)) of the top plate from each ingot in each lot. For continuous cast slabs, specimens shall be taken from either the Charpy V-notch or dynamic tear specimens at mid-thickness from one location in one plate in each lot.

A.4.4.2.3 Sampling for Tensile Test. After final heat treatment of the lot, a transverse tensile test specimen shall be taken from each end of the plate, sheet, or coil (see A.4.4.1.2). The tensile specimen shall be located as shown on [Figure A-3](#) and [Figure A-4](#) and one surface of the specimen shall be at a depth as near as practicable to T/2 below the surface, where T is the as-heat-treated thickness of the plate, and not less than three times the plate thickness or 4 inches (102 mm), whichever is less, from the as-heat-treated edge and not more than 12 inches (305 mm) from the ends of the plate, sheet, or coil. In addition, for plate thickness of 3 inches (76 mm) or greater, a through-thickness tensile specimen (see note 6 to [Table A-2](#)) shall be taken from the same location as the sample for chemical analysis (see A.4.4.2.2).

A.4.4.2.4 Sampling for Impact Test. After final heat treatment of the lot, the test specimens shall be located as shown on [Figure A-3](#) and [Figure A-4](#) and be not less than three times the plate thickness or 4 inches (102 mm), whichever is less, from the as-heat-treated edge and not more than 12 inches (305 mm) from the ends of the plate, sheet, or coil.

A.4.4.2.4.1 Sampling for Charpy V-Notch Impact Test. From each plate, sheet, or coil, three transverse Charpy V-notch test specimens shall be taken from each end for each test temperature. The specimens shall be so located in the thickness of the plate, that, for 20.4 lb/ft² [100 kg/m²] (½ inch or 13 mm thick) to 25.5 lb/ft² [125 kg/m²] (⅝ inch or 16 mm thick), the

plate surface (after light machining) shall be one face of the specimen. For plates 25.5 lb/ft² [125 kg/m²] ($\frac{5}{8}$ inch or 16 mm thick) and heavier, the centerline of the plate shall be in one face of the specimen. The notch shall be perpendicular to the plate rolled surface.

A.4.4.2.4.2 Sampling for Dynamic Tear Impact Test. In the case of dynamic tear testing, one transverse dynamic tear test specimen shall be taken from each end of the plate. The dynamic tear specimens shall be located in the thickness of the plate, such that the centerline of the plate shall be the centerline of the specimen. The notch shall be perpendicular to the plate rolled surface.

A.4.4.2.5 Thermal Buffer Pad Requirements. Where the crop is insufficient to obtain test specimens, thermal buffer pads in accordance with ASTM A20 shall be used to maintain the proper distance from the heat treated edge of the plate.

A.4.4.2.6 Sampling for Thickness Testing. Each plate, sheet, or coil shall be thickness tested in accordance with A.4.6.4 and A.4.6.5.2.

A.4.5 Visual Examination. Each plate shall be examined visually and shall meet the requirements of A.3.6. With respect to coating applications, the number of plates subject to paint film thickness measurements should be held to the minimum necessary to assure continued satisfactory performance. Paint thickness measurements shall be in accordance with Appendix K.

A.4.6 Test Procedures. See [Table A-11](#) and 4.5.

A.4.6.1 Chemical Analysis. Conformance inspection samples selected in accordance with A.4.4.2.2 shall be analyzed in accordance with 4.5.1. If the samples from the inspected plate, sheet, or coil fail to meet the requirements, all material from the lot in question shall be rejected. Samples from rejected lots of plates, sheets, or coils may be analyzed individually provided the samples are taken from each in the specified locations, and only those plates, sheets, or coils which conform to chemical composition requirements in A.3.2 will be accepted. Test results shall meet the requirements of [Table A-1](#).

A.4.6.2 Tensile Test. See 4.5.2 and A.3.3.

A.4.6.3 Impact Toughness.

A.4.6.3.1 Charpy V-Notch Impact Test. Conformance inspection test specimens shall be tested with coolant temperatures as specified in [Table A-3](#). Specimens for first article and conformance tests shall be so located in the thickness of the plate that, for 5.1 to 35.7 lb/ft² [25 to 174 kg/m²] ($\frac{1}{8}$ to $\frac{7}{8}$ inch thick or 3 mm to 22 mm thick), the plate surface (after light machining) shall be one face of the specimen, and for plates 35.7 lb/ft² [174 kg/m²] ($\frac{7}{8}$ inch or 22 mm thick) and heavier, the centerline of the plate shall be one face of the specimen. The notch shall be perpendicular to the plate surface. For first article testing, Charpy V-notch transition curves (transverse to rolling direction) with data points at each temperature of minus 120 °F (minus 84 °C), minus 90 °F (minus 68 °C), minus 60 °F (minus 51 °C), minus 30 °F (minus 34 °C), 0 °F (minus 18 °C), and room temperature shall be provided. At least three specimens for each point are required and individual values shall be recorded.

A.4.6.3.2 Dynamic Tear Impact Test. For first article and conformance inspection, test specimens shall be tested as specified in [Table A-3](#). Dynamic tear specimens shall be located such that, for plates 25.5 lb/ft² [125 kg/m²] ($\frac{5}{8}$ inch or 16 mm thick) to 51 lb/ft² [249 kg/m²] (1 $\frac{1}{4}$ inches or 32 mm thick), the plate surface (after light machining or grinding to remove paint and heat treatment scale) shall be one face of the specimen, and for plates 51 lb/ft² [249 kg/m²] (1 $\frac{1}{4}$ inches or 32 mm thick) and heavier, the centerline of the plate shall be the centerline of the specimen. The notch shall be perpendicular to the plate rolled surface.

A.4.6.3.3 Drop Weight Nil-Ductility Test. For first article inspection, the test specimen shall be tested in accordance with ASTM E208.

A.4.6.3.4 Marking of Test Specimens. The test specimens shall be marked to ensure positive identification of the lot being tested.

A.4.6.4 Gauging. Each plate, sheet, or coil shall be measured with a calibrated micrometer at three evenly distributed points along each longitudinal edge and at two evenly distributed points along each transverse edge.

A.4.6.5 Ultrasonic Examination. The requirements of T9074-AS-GIB-010/271 shall apply for the qualification of ultrasonic testing personnel, qualification and calibration of equipment, qualification of procedures, and reporting of test results. The scanning surface of the plate may have one coat each of pretreatment and primer.

A.4.6.5.1 Ultrasonic Soundness. Examinations shall be performed in accordance with ASTM A435, including the Supplementary Requirements of S1, and shall meet the acceptance standards stated therein.

T9074-BD-GIB-010/0300 Rev 2

A.4.6.5.2 Ultrasonic Thickness. Examinations shall be performed in accordance with Appendix J and meet the requirements of [Table A-5](#) and [Table A-6](#) herein. When plate is specified on a lb/ft² basis, ultrasonic inspection for thickness is not required.

A.4.6.6 Documentation. Records of thickness measurements and soundness (see A.3.8.1) shall be prepared and transmitted with the material.

A.4.6.7 Microstructure Analysis.

A.4.6.7.1 Prior Austenite Grain Size. For first article inspection, the average prior austenite grain size shall be determined in accordance with the planimetric procedure of ASTM E112 for the product in the final heat treated condition.

A.4.6.7.2 Microstructure. The microstructure at the centerline of the thickest plate to be qualified shall be reported in the form of photomicrographs showing the relative quantities and morphologies of the phases present.

A.4.6.8 Explosion Test. The thickness of the explosion crack starter specimen and explosion bulge specimens, when specified (see A.6.2), shall be 1 inch (25 mm) for HSLA-80 and 1 inch (25 mm) for HSLA-100 Composition 1 plate, 1⁵/₈ inch (41 mm) for HSLA-100 Composition 2 plate, or 2 inches (51 mm) for HSLA-100 Composition 3 plate depending on grade and chemical composition type for HSLA-100 being qualified (see A.4.3 and Appendix L). The required composition types for HSLA-100 are specified in [Table A-1](#). The tests will be conducted under Government direction to evaluate plate and weldment performance. Unless otherwise specified (see A.6.2), the explosion test shall be conducted at 0 °F (minus 18 °C).

A.5 PACKAGING.

See Chapter 5.

A.6 NOTES.

A.6.1 Intended Use. Grades HSLA-80 and HSLA-100 high-strength age-hardened alloy steel plates are intended primarily for use in structural applications where notch-tough, high-strength welded steels are required. The use of steel at these strength levels and at these required toughness levels, as fabricated structure or equipment, entails much more than a material specification, and caution is advised in the area of welding, fabrication, and nondestructive testing. The yield/tensile strength ratios of HSLA-80 and HSLA-100 may be higher than those of HY-80 and HY-100, respectively, and should be noted and considered by designers.

A.6.2 Acquisition Requirements. Acquisition documents must specify the following:

- a. Title, number, and date of this specification.
- b. Type and grade of steel plate, sheet, or coil required (see A.1.2).
- c. If steel plate over ½ inch (13 mm) is not required to be classified as Type II (see A.1.2).
- d. Absorbed energy required of sub-sized specimens (see note 4 of [Table A-3](#)).
- e. Detailed procedure for heat treatment, if other than specified, and class of heat treatment required (see A.3.5 and A.3.5.a).
- f. If weld repair after final heat treatment is not permitted (see A.3.6.1).
- g. When ASTM A6 dimensional tolerances shall be used (see A.3.7.2).
- h. When plates over ½ inch (13 mm) thick are not to be ultrasonically inspected and measured for decimal thickness (see A.3.8).
- i. When Type I plates, sheets, and coil are to be ultrasonically inspected for soundness (see A.3.8).
- j. Applicable fabrication document required (see A.3.9).
- k. When descaling and coating are not required (see A.3.10).
- l. Type and thickness of coating required (see A.3.10).
- m. If explosion bulge type testing is required for first article testing (see A.3.12 and A.4.6.8).
- n. Test temperature required when nil-ductility testing HSLA-100 (see A.3.13).
- o. If specimens for first article testing shall be located and tested other than as specified on [Figure A-1](#) and [Figure A-2](#) (see A.4.3.1).

p. When explosion test temperature is other than specified (see A.4.6.8).

A.6.3 Thin Plates. Plates under 7.65 lb/ft² (37.4 kg/m²) should be ordered under this specification only when they are for structural purposes where strength and gauge are important.

A.6.4 First Article. See 6.3.

A.6.5 Receipt Inspection. The plates should be subject to receipt inspection (including chemical composition and mechanical property tests) by consignee to verify conformance to all requirements of the specification. Plates not conforming to the requirements of the specification at any location in the plate may be rejected by the consignee. The plate manufacturer may verify the results of the consignee's receipt inspection. It is the responsibility of the consignee to determine acceptability of the plates for the intended application.

T9074-BD-GIB-010/0300 Rev 2

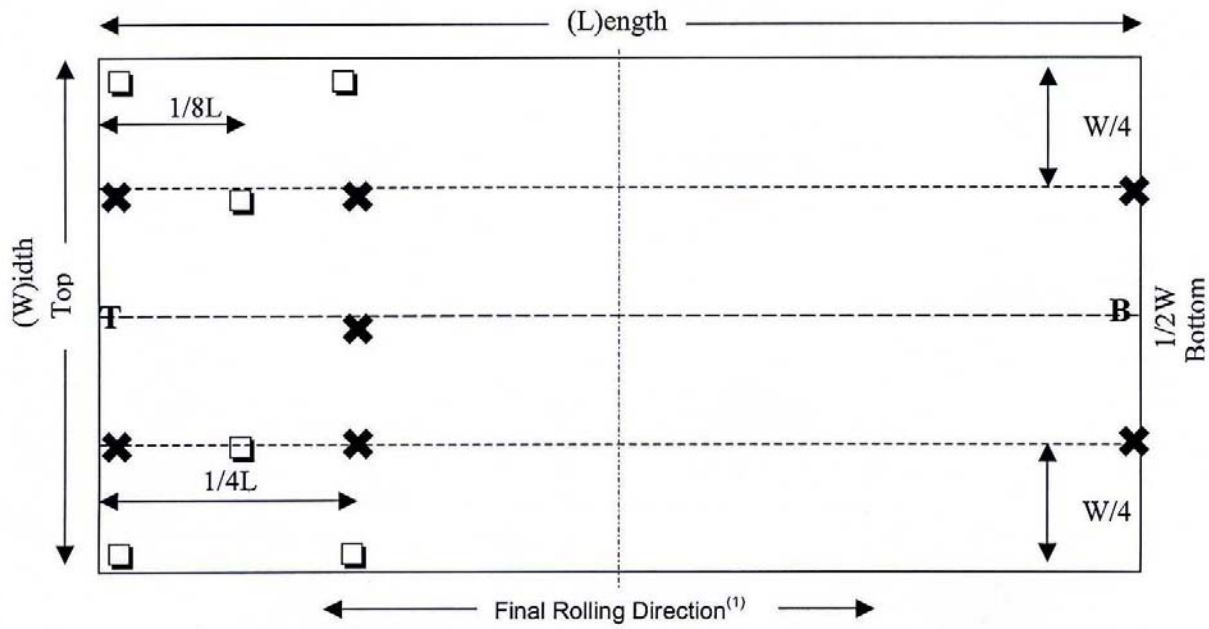

Test	Location Symbol	Comments
Tensile (longitudinal) ⁽²⁾	✘	Surface and mid-thickness depth (1 test at room temperature at each location).
Tensile (transverse) ⁽³⁾	✘	Surface and mid-thickness depth (1 test at room temperature at each location).
Chemical Composition	✘	Full chemistry from all broken transverse tensiles.
Chemical Composition ⁽⁴⁾	□	Full chemistry from surface and mid-thickness location.
CVN (transverse) ⁽²⁾	✘	See A.4.6.3 for specimen depth (3 tests at -120 °F and 3 tests at 0 °F, at each location).
CVN Transition Curve ⁽⁵⁾	▲	See A.4.6.3 for specimen depth and test temperature.
5/8 Inch DT Transition Curve (transverse) ⁽⁵⁾	○	See A.4.6.3 for specimen depth (3 tests at each of the following temperatures: -80 °F, -40 °F, 0 °F, 40 °F, and room temperature).
Drop Weight Nil-Ductility Test ⁽³⁾	*	Surface specimen test in accordance with ASTM E208 and A.3.13.
Macrostructure/ Microstructure	✘	In accordance with A.4.6.7.
Multiple Tests	T	Conduct the following tests at this location: ✘, □, ○, ▲, *
Multiple Tests	B	Conduct the following tests at this location: ✘, □, *

NOTES:

- (1) The final rolling direction is the direction of rolling in which the greatest reduction ratio is achieved. For example, if 25 percent reduction of the initial slab or ingot thickness is achieved by rolling in direction A, and 75 percent reduction of the initial thickness is achieved by rolling in direction B, then direction B is the final rolling direction.
- (2) CVN specimens and longitudinal tensile, from the top and bottom locations, shall be removed from material up to 12 inches from the as-cut edge of the plate, but not closer than 4 inches from the as-heat-treated edge of the plate.
- (3) Transverse tensile specimens from top and bottom locations shall be removed from the as-cut edge of the plate, but not closer than 4 inches from the as-heat-treated edge of the plate.
- (4) Specimens shall be removed from as-cut edge(s) of the plate, but not closer than 4 inches from as-heat-treated edge of the plate.
- (5) Specimens shall be removed from material up to 12 inches, but not closer than 4 inches from the as-heat-treated edge of the plate.

Figure A-1. First Article Inspection Testing (Plate <3 Inches Thick).

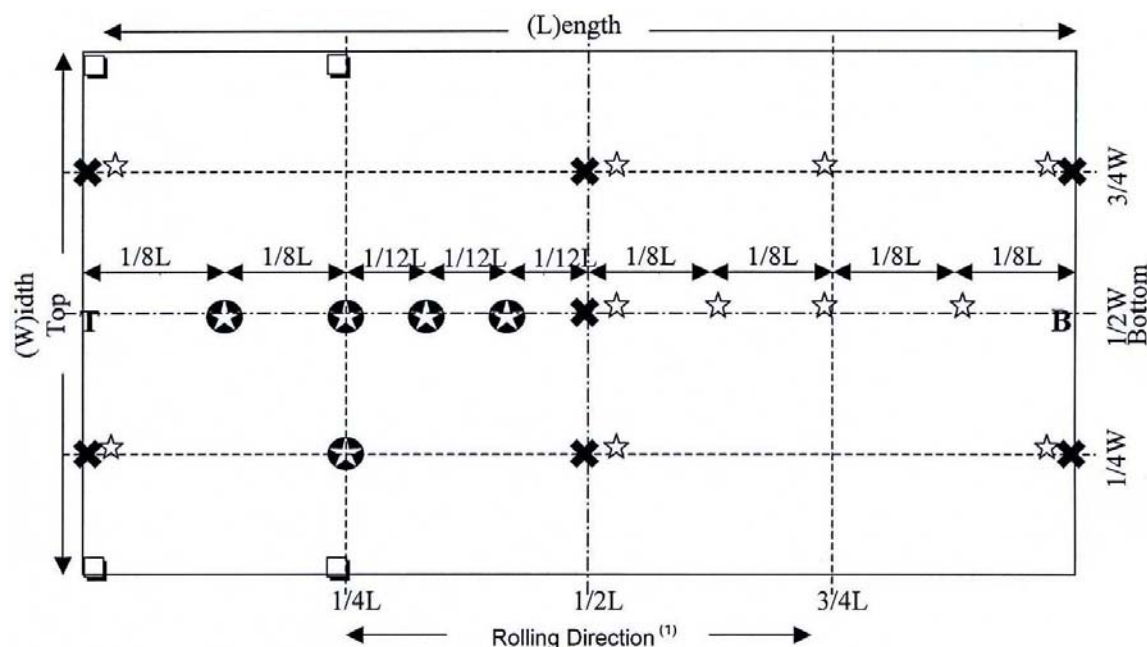

Test	Location Symbol	Comments
Tensile (longitudinal) ⁽²⁾	✖	Surface and mid-thickness depth (1 test at room temperature at each location).
Tensile (transverse) ⁽³⁾	✖	Surface and mid-thickness depth (1 test at room temperature at each location).
Tensile (through thickness) ⁽²⁾	☆	Mid-length of specimen at mid-thickness depth (2 tests at each location).
Chemical Composition	✖	Full chemistry from all broken transverse tensiles.
Chemical Composition and Through Thickness Tensile	⊛	Full chemistry from gage length of one broken through thickness tensile.
Chemical Composition ⁽⁴⁾	□	Full chemistry from surface and mid-thickness location.
CVN (transverse) ⁽²⁾	✖	See A.4.6.3 for specimen depth (3 tests at -120 °F and 3 tests at 0 °F, at each location).
CVN Transition Curve ⁽⁵⁾	▲	See A.4.6.3 for specimen depth and test temperature.
5/8 Inch DT Transition Curve (transverse) ⁽⁵⁾	○	See A.4.6.3 for specimen depth (3 tests at each of the following temperatures: -80 °F, -40 °F, 0 °F, 40 °F, and room temperature).
Drop Weight Nil-Ductility Test ⁽⁵⁾	✱	Surface specimen test in accordance with ASTM E208 and A.3.13.
Macrostructure/ Microstructure	✖	In accordance with A.4.6.7.
Multiple Tests	T	Conduct the following tests at this location: ✖, ☆, □, ▲, ○, ✱
Multiple Tests	B	Conduct the following tests at this location: ✖, ☆, □, ✱

NOTES:

- (1) The final rolling direction is the direction of rolling in which the greatest reduction ratio is achieved. For example, if 25 percent reduction of the initial slab or ingot thickness is achieved by rolling in direction A, and 75 percent reduction of the initial thickness is achieved by rolling in direction B, then direction B is the final rolling direction.
- (2) Longitudinal tensile, through thickness tensile and CVN specimens, from the top and bottom locations, shall be removed from material up to 12 inches from the as-cut edge of the plate, but not closer than 4 inches from the as-heat-treated edge of the plate.
- (3) Transverse tensile specimens from top and bottom locations shall be removed from the as-cut edge of the plate, but not closer than 4 inches from the as-heat-treated edge of the plate.
- (4) Specimens shall be removed from as-cut edge(s) of the plate, but not closer than 4 inches from as-heat-treated edge of the plate.
- (5) Specimens shall be removed from material up to 12 inches, but not closer than 4 inches from the as-heat-treated edge of the plate.

Figure A-2. First Article Inspection Testing (Plate ≥3 Inches Thick).

T9074-BD-GIB-010/0300 Rev 2

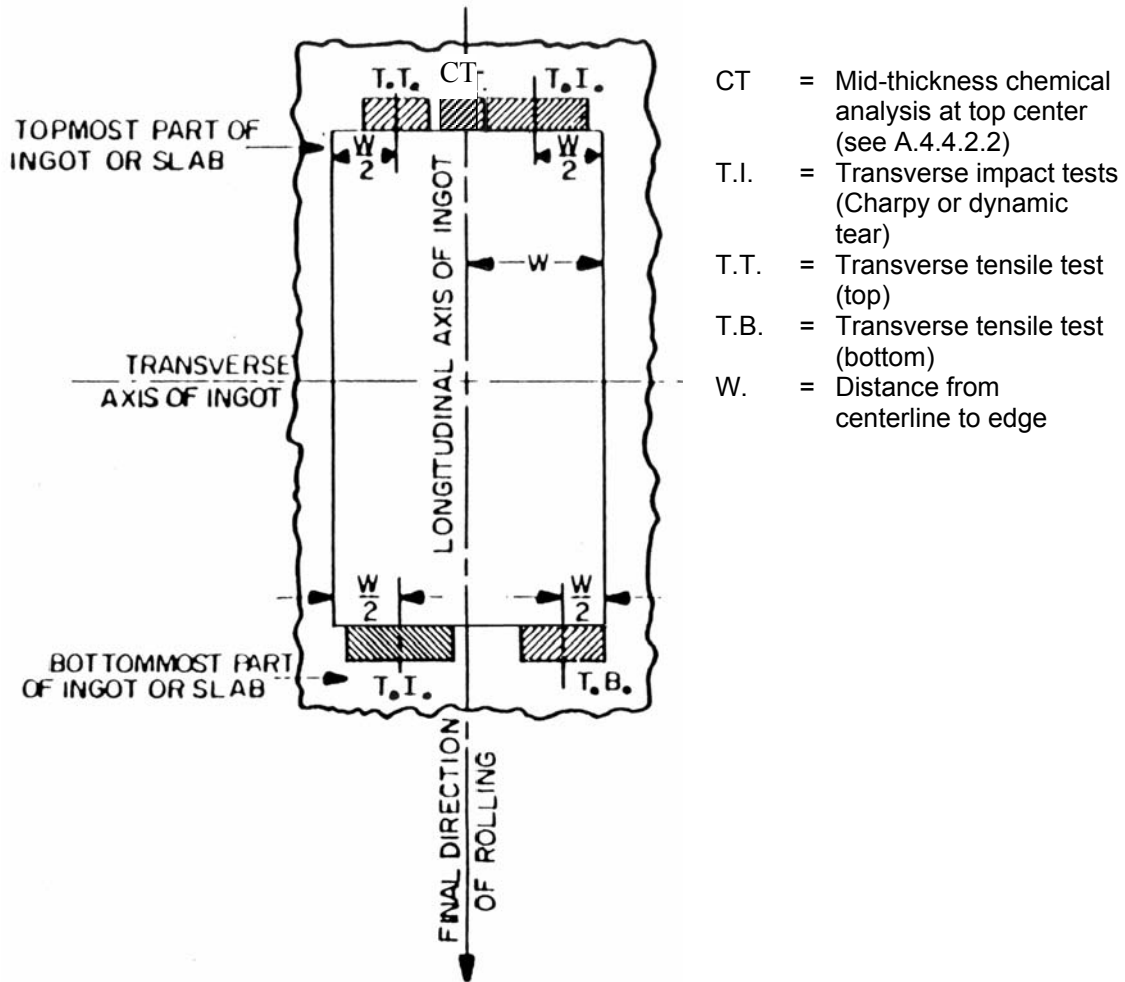

Figure A-3. Method of Locating Test Specimens for Conformance Inspection of Plates as Rolled from Ingots or Slabs with the Final Direction of Rolling Parallel to the Longitudinal Axis of the Ingot.

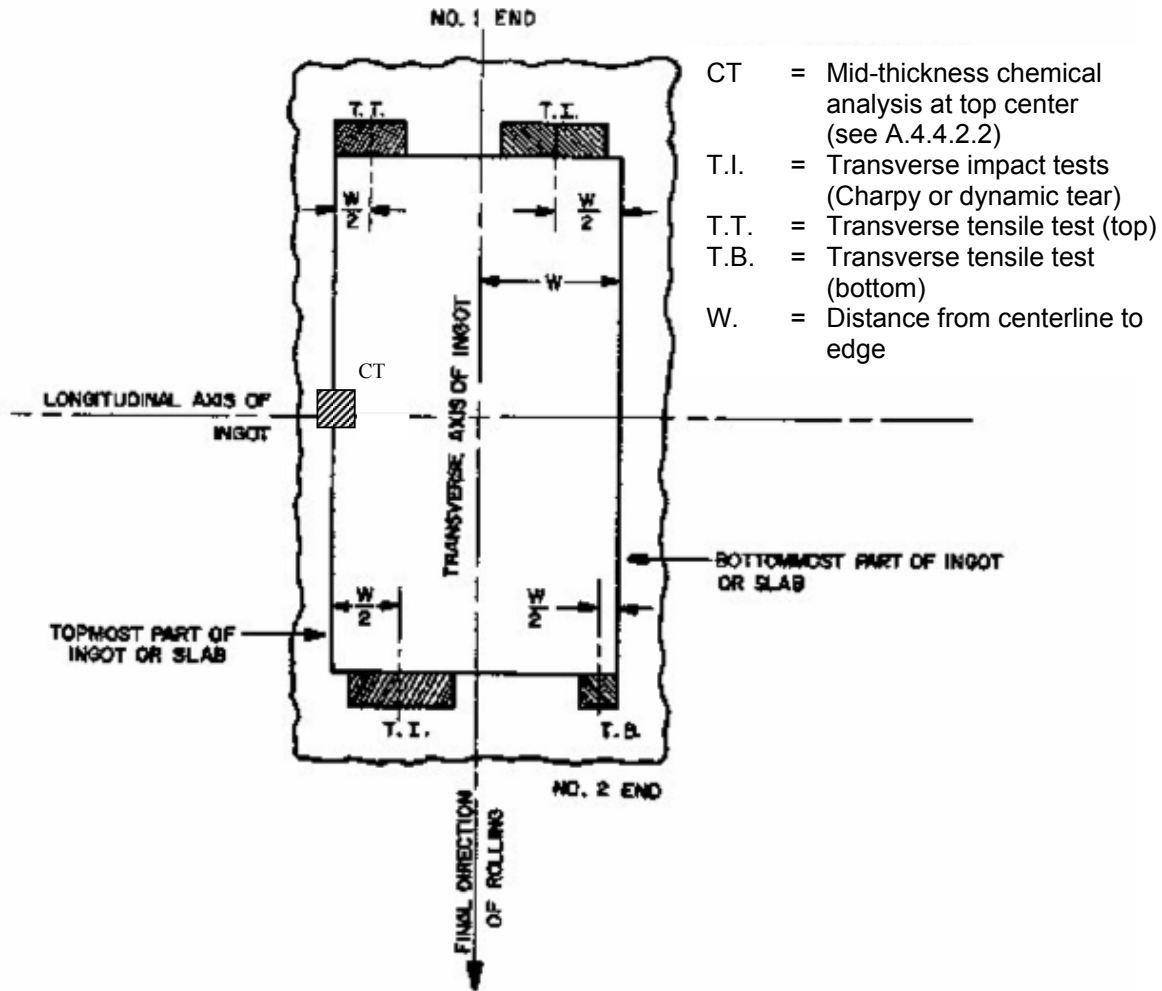

Figure A-4. Method of Locating Test Specimens for Conformance Inspection of Plates as Rolled from Ingots or Slabs with the Final Direction of Rolling Parallel to the Transverse Axis of the Ingot.

T9074-BD-GIB-010/0300 Rev 2

	0	30	54	78	102	126	150	174	
0	+	+	+	+	+	+	+	+	MILL MARK NO.
									HEAT/MELT NO.
									SLAB/PLATE NO.
30	+	+	+	+	+	+	+	+	MATERIAL
									LENGTH
									WIDTH
									GAGE
54	+	+	+	+	+	+	+	+	RECORDABLE SOUNDNESS DISCONTINUITIES
									FLAW CLASS *
									DIMENSION TO: TOP END
78	+	+	+	+	+	+	+	+	FLAW CLASS *
									DIMENSION TO: TOP END
									LEFT SIDE
102	+	+	+	+	+	+	+	+	
126	+	+	+	+	+	+	+	+	
150	+	+	+	+	+	+	+	+	
174	+	+	+	+	+	+	+	+	
198	+	+	+	+	+	+	+	+	
222	+	+	+	+	+	+	+	+	
246	+	+	+	+	+	+	+	+	
270	+	+	+	+	+	+	+	+	*KEY (SEE 40.2.2.3.2)
									REC-ACCEPTABLE DISCONTINUITY
									REJ-REJECTABLE DISCONTINUITY
294	+	+	+	+	+	+	+	+	<input type="checkbox"/> SOUNDNESS SATISFACTORY
									<input type="checkbox"/> REFER EVALUATION
318	+	+	+	+	+	+	+	+	REMARKS
342	+	+	+	+	+	+	+	+	
366	+	+	+	+	+	+	+	+	SPECIFICATION/PROCEDURE
390	+	+	+	+	+	+	+	+	INSPECTOR/CERT. LEVEL MODEL NO.
414	+	+	+	+	+	+	+	+	SEARCH UNIT: SIZE FREQUENCY MHz
438	+	+	+	+	+	+	+	+	INSPECTOR(S): DATE
									REVIEWED BY: DATE

Figure A-5. Sample Plate Ultrasonic Soundness Report.

APPENDIX B (16216) STEEL PLATE, ALLOY, STRUCTURAL, HIGH YIELD STRENGTH (HY-80 and HY-100)

B.1 SCOPE.

B.1.1 Scope. This appendix covers Grade HY-80 and Grade HY-100, sheared or gas-cut, alloy steel plates, intended primarily for use in critical applications where a notch-tough, high-strength material is required. The requirements apply to Grade HY-80 plate up to 8 inches (203 mm) thick, and to Grade HY-100 plate up to 6 inches (152 mm) thick.

B.1.2 Classification. Steel plate covered by this appendix shall be of the following types and grades, as specified (see B.6.2):

- | | |
|--------------|---|
| Type I | - Plate where ultrasonic testing for soundness and thickness is not performed. |
| Type II | - Plate over ½ inch (13 mm) in thickness where ultrasonic testing for soundness and thickness is performed. Unless otherwise specified (see B.3.7 and B.6.2), each plate over ½ inch (13 mm) in thickness shall be classified as Type II. |
| Grade HY-80 | - 80,000 lb/in ² (80 ksi) [552 MPa] tensile yield strength, minimum. |
| Grade HY-100 | - 100,000 lb/in ² (100 ksi) [690 MPa] tensile yield strength, minimum. |

B.2 APPLICABLE DOCUMENTS.

See Chapter 2.

B.3 REQUIREMENTS.

B.3.1 Material. The steel shall be vacuum degassed and, if the purchaser requires, shall consist of only virgin materials (see B.6.2).

B.3.2 Chemical Composition. The chemical composition shall conform to [Table B-1](#). In cases where both heat and product analyses are determined, the product analysis shall be used to determine acceptance or rejection (see B.4.6.1).

T9074-BD-GIB-010/0300 Rev 2

Table B-1. Chemical Composition (Weight Percent). 1/

Element	Thickness, inches (millimeters)					
	To 1¼ (32), inclusive		Over 1¼ (32) to 3 (76), inclusive		Over 3 (76)	
	Grade HY-80	Grade HY-100	Grade HY-80	Grade HY-100	Grade HY-80	Grade HY-100
Carbon <u>2/</u> , <u>3/</u>	0.10 – 0.18		0.13 – 0.18	0.14 – 0.20	0.13 – 0.18	0.14 – 0.20
Manganese	0.10 – 0.40					
Phosphorus	0.015					
Sulfur	0.004					
Silicon <u>4/</u>	0.15 – 0.38					
Nickel	2.00 – 3.25	2.25 – 3.50	2.50 – 3.50	2.75 – 3.50	3.00 – 3.50	
Chromium	1.00 – 1.80		1.40 – 1.80		1.50 – 1.90	
Molybdenum	0.20 – 0.60		0.35 – 0.60		0.50 – 0.65	
Vanadium <u>5/</u>	0.03					
Titanium <u>5/</u>	0.02					
Copper <u>5/</u>	0.25					
Antimony <u>5/</u>	0.025					
Arsenic <u>5/</u>	0.025					
Tin <u>5/</u>	0.030					

NOTES:

1/ Single values are maximum percentages. Except for carbon and sulfur, the chemical analysis tolerances, as specified in ASTM A6, are to be applied to product (check) analysis. The product analysis tolerance for carbon in Grade HY-80 plate less than 6 inches (152 mm) thick is 0.02 percent over the maximum specified. The product analysis tolerance for sulfur is 0.002 percent over the maximum specified for all products. For elements not listed in ASTM A6, the product analysis shall not exceed the specified maximum.

2/ For Grade HY-80 plate 6 inches (152 mm) and over, add 0.02 percent to the upper limit.

3/ For plate ¾ inch (9.5 mm) and under, minimum carbon may be reduced to 0.08 percent.

4/ When vacuum carbon deoxidation is employed, the minimum silicon content may be reduced to 0.08 percent, in which case the steel shall be fully killed and shall not be active in the molds during teeming.

5/ Elements shall not be added intentionally.

B.3.3 Tensile Properties. The material shall meet the tensile property requirements as specified in [Table B-2](#) after all heat treatments, including stress relief.

B.3.3.1 Ultimate Tensile Strength. When specified (see B.6.2), ultimate tensile strength requirements shall be met.

Table B-2. Tensile Property Requirements.

	Nominal Thickness, inches (millimeters)			
	≤0.75 (19)	>0.75 (19)	≤0.75 (19)	>0.75 (19)
	Grade HY-80		Grade HY-100	
Ultimate tensile strength, ksi [MPa]	<u>1/</u>			
Yield strength, 0.2 percent offset, ksi [MPa]	80-100 <u>2/</u> [552-690]	80-99.5 [552-686]	100-120 [690-827]	100-120 [690-827]
Elongation in 2 in. (50 mm), min (percent) <u>3/</u>	19	20	17	18
Reduction in area, minimum, round specimen (percent)	---	50 <u>4/</u>	---	45 <u>4/</u>
NOTES:				
<u>1/</u> Unless otherwise specified (see B.6.2), this value to be recorded for information only.				
<u>2/</u> For plates and sheets $\frac{3}{8}$ inch (9.5 mm) and less in thickness, the maximum yield strength shall be 110 ksi [758 MPa].				
<u>3/</u> For plates and sheets $\frac{1}{4}$ inch (6.4 mm) and less in thickness, elongation shall be 14 percent minimum for Grade HY-80 and 12 percent minimum for Grade HY-100.				
<u>4/</u> Through-thickness tensile testing is required for plate greater than or equal to 3 inches thick. The only requirement for through-thickness tensile tests is for reduction of area to be a minimum of 20 percent. There is no requirement for yield strength or elongation.				

B.3.4 **Impact Tests.** Impact test requirements for conformance testing shall be conducted as described in [Table B-3](#).

Table B-3. Impact Test Application.

Material Thickness		Applicable Test
Inches	Millimeters	
$\frac{1}{2}$ thru $\frac{5}{8}$	13 thru 16	Charpy V-notch
Over $\frac{5}{8}$ to 4, exclusive	Over 16 to 102, exclusive	Dynamic tear
4 thru 8	102 thru 203	Dynamic tear

B.3.4.1 **Impact Properties.** The material shall meet the impact property requirements as specified in [Table B-4](#) after all heat treatments, including stress relief.

T9074-BD-GIB-010/0300 Rev 2

Table B-4. Impact Test Requirements for First Article and Conformance Testing. 1/

Nominal Plate Thickness		Temperature 2/		Dynamic Tear 3/		Charpy V-Notch 4/		Minimum Shear Fracture, percent 5/
Inches	(Millimeters)	°F	(°C)	HY-80, ft-lbs (J)	HY-100, ft-lbs (J)	HY-80, ft-lbs (J)	HY-100, ft-lbs (J)	
Over 5/8 thru 8	(16 thru 203)	-40	(-40)	450 (610)				
Over 5/8 thru 6	(16 thru 152)	-40	(-40)		500 (678)			
1/2 thru 6	(13 thru 152)	-120	(-84)			35 (47)		50
		0	(-18)			60 (81)		90
Over 6 thru 8	(Over 152 thru 203)	-120	(-84)			30 (41)		40
		0	(-18)			60 (81)		90
1/2 to 4	(13 thru 102)	-120	(-84)				40 (54)	50
		0	(-18)				60 (81)	90
Over 4 thru 6	(Over 102 thru 152)	-120	(-84)				35 (47)	40
		0	(-18)				60 (81)	90

NOTES:

1/ Sampling and location of test specimens shall be as specified in B.4.4.2.1, B.4.4.2.4, and B.4.4.2.5.

2/ Tolerance for temperature tests shall be ± 3 °F or ± 2 °C.

3/ Test requirements are based on a minimum average of two specimens; no single value shall be below the minimum by more than 25 ft-lbs (34 J).

4/ Test requirements are based on a minimum average of three specimens; no single value shall be below the minimum by more than 5 ft-lbs (7 J).

5/ Measurement required on each Charpy V-notch specimen. No individual result shall be lower than the minimum.

B.3.5 Heat Treatment. Plate shall meet the mechanical requirements of this appendix with the following restrictions:

- The plates shall be quenched and tempered. The tempering temperature shall be not less than the temperature specified in [Table B-5](#). The tempering temperature for HY-80 and HY-100 at any location on the plates shall not exceed 1265 °F (685 °C). A higher tempering temperature may be used provided that the supplier first demonstrates that the tempering temperature to be used is at least 25 °F (14 °C) below the lower critical temperature for the material. All plates that constitute the tempering or stress relief furnace load for batch-type furnaces shall be removed from the furnace and rapidly cooled by water quenching at the same time (i.e., the same quench load). The use of more than one quench load for tempering or stress relief heat treatment of a single batch-type furnace load of plates is prohibited.
- If the plates are stress relieved after final tempering, the stress relief temperature shall be not less than the temperature specified in [Table B-5](#) and shall not exceed the tempering temperature. The plates shall be rapidly cooled following stress relief.
- For all heat treatment operations, plates shall be positioned and supported in such a manner as to prevent shifting or falling from their initial set positions during the heat treatment process. In addition, during tempering, plates shall be positioned in the furnace so that, in a direct-fired furnace, burner flames and hot gases from these flames cannot impinge upon plate surfaces and result in heating the plates above the maximum allowable tempering temperature. As a minimum, the plates shall be supported in the furnace in a manner that ensures that the plates cannot fall or shift outside of the furnace working zone and be exposed to burner flames or hot gases. Attention shall be given to ensuring that the structure supporting the plate, such as pylons, sawhorses, and racks, will not deflect flames and hot gases onto plate surfaces.
- In addition to the requirements of 3.5 for batch-type furnaces, the heat treatment record shall also include digital photographs and sketches providing sufficient accuracy to recreate positions and orientations of the plates in the furnace at future dates. The sketches shall identify every part in the load uniquely according to a vendor's internal tracking methodology. The sketches and photographs in the heat treatment record shall be of the furnace car plate-

load immediately prior to entering the furnace for the tempering cycle(s). Manufacturer Standard Practices shall be established, which shall include placement of plates, plate support structure (i.e., pylons, saw horses, racks, etc.) on the furnace car, placement of the burners in the furnace, and the distances and orientations of the plates and support structure with respect to the burners. The verification of inspection record shall validate the plate was loaded in accordance with the sketches and photographs in the heat treatment record and the Manufacturer Standard Practices.

- e. The quench tank facility used after the austenitizing heat treatment for quenching shall be of a sufficient capacity and design to provide multi-directional (from at least three directions or other equivalent design based on data and on results of first article testing) water flow for effective quenching of the largest plates to be heat treated. The effectiveness of the quench tank facility used after the austenitizing, tempering, and (if applicable) stress relief heat treatments in terms of capacity and water flow shall be demonstrated during first article testing. The maximum quench tank water temperature at the initiation of the quenching operation shall not exceed 80 °F (27 °C). The mill shall institute a process to maintain the effectiveness (e.g., flow rate and water capacity) of the quench tank similar to that used during the first article qualification.
- f. As an alternate to the thermal survey requirements of SAE AMS-H-6875, all furnaces that are used to heat-treat plates over ¼-inch (6.4-mm) gage may be thermally surveyed as follows:
 - (1) The initial survey is done once using the thinnest and thickest gage plate; the following surveys may use any gage.
 - (2) Furnaces must be surveyed every 6 months after the initial survey.
 - (3) Thermal surveys are conducted as follows:
 - (a) Three contact thermocouples must be used, one at each edge and one in the middle across the width of the plate.
 - (b) A calibrated recording device and thermocouples must be used.
 - (c) The test plate is run through the furnace using standard hold times.
 - (d) Trial starts when plate exits heat-up zones, and ends when plate exits furnace.
 - (e) Maximum temperature variability when plate is in soaking zones is ±25 °F (±14 °C).

B.3.5.1 Thermal Hydrogen Soak After Hot Rolling. All plate greater than 3 inches (76 mm) thick shall receive a post hot rolling soak using a procedure demonstrated to the requirements in B.4.3, unless otherwise approved by NAVSEA.

Table B-5. Minimum Tempering and Stress Relief Temperatures.

Nominal Plate Thickness, inches, (millimeters)		Minimum Tempering Temperature		Minimum Stress Relief Temperature	
		°F	°C	°F	°C
HY-80	2½ (64) and less	1200	649	1100	593
HY-80	Over 2½ (64) to 8 (203)	1175	635	1100	593
HY-100	2½ (64) and less	1150	621	1050	566
HY-100	Over 2½ (64) to 6 (152)	1100	593	1050	566

B.3.5.2 Simulated Stress Relief. When a simulated stress relief is required (see B.6.2), a sample from the same heat treated lot (see B.4.4.1.1) shall be subjected to stress relief thermal cycles and then be sampled for tensile and impact mechanical properties in accordance with B.4.4, and shall meet the requirements of B.3.3 and B.3.4.1. The contracting activity will specify the stress relief thermal cycles (including cooling rates) to the Contractor. Stress relief is to be specified only when necessary to meet machining tolerances. The stress relief time and temperature shall be equal to or greater than the stress relief cycle anticipated for the production plate.

B.3.6 Surface Quality. The depth of rolled-in scale, pits, windrowed condition, or other defects shall not exceed 0.015 inch (0.38 mm) and shall not result in an under gauge (less than minimum thickness) condition. Isolated, individual pits not over 0.030 inch (0.76 mm) deep are acceptable, provided plate thickness is not reduced to an under gauge condition. Surface imperfections may be removed by grinding, provided the thickness is not reduced to an under gauge condition and the width of the ground area is three times its depth and radially tapered into the defect.

T9074-BD-GIB-010/0300 Rev 2

B.3.6.1 Weld Repair of Mill Defects After Heat Treatment. When specified, weld repair after final heat treatment is prohibited or shall be conducted in accordance with processing and inspection standards other than those shown below in B.3.6.1.e, B.3.6.1.f, and B.3.6.1.h (see B.6.2). Mill imperfections may be repair welded or referred to the contracting activity for acceptance and so noted on the inspection reports. Areas of the plate found to have less than the minimum specified thickness may have the thickness restored by welding the depressed area. When weld repairs after final heat treatment are permitted, the following limitations shall apply:

- a. The total area to be repaired shall not exceed 1 percent of the surface of one side of the plate.
- b. The depth of any area to be repaired shall not exceed one-half the minimum plate thickness specified or ½ inch (13 mm), whichever is less. The depth of the area to be repaired shall be a minimum of ⅙ inch (1.6 mm).
- c. Areas within 2 inches (51 mm) of each other which require weld repair shall be combined to form a single repair.
- d. All of the areas to be welded shall be ground sufficiently to assure that the welds are made on clean, sound metal.
- e. After preparation for repair and prior to welding, all of the depressed areas shall be magnetic particle inspected in accordance with T9074-AS-GIB-010/271, and shall be free of relevant linear indications.
- f. Weld repairs shall be made in accordance with T9074-AD-GIB-010/1688, or the applicable fabrication document (see B.3.8). Procedures and personnel shall be qualified in accordance with S9074-AQ-GIB-010/248.
- g. The final repaired surface shall be ground smooth and shall be essentially flush with the adjacent surface and free of undercut in excess of 0.020 inch (0.5 mm). No point of the finished weld surface shall be below the adjacent plate surface.
- h. Plates or segments of plates containing surface weld repairs shall be magnetic particle inspected after final grinding (or subsequent heat treatment, if applicable) in accordance with T9074-AS-GIB-010/271. All welds ½ inch (13 mm) of adjacent base material shall be free of relevant linear indications greater than ⅛ inch (3 mm) in length.
- i. Repaired areas shall be marked. The markings shall remain legible and shall not be removed prior to performing all inspections as required by this document.
- j. Notations of such repaired areas and the type of welding filler metal used to make the weld repair(s) shall be made on the plate inspection form as part of the records.
- k. If a non-heat treatable electrode is used, reheat treatment of the plate, except for stress relief, is prohibited.
- l. MIL-120S-1 and MIL-12018-M2 or equivalent strength welding consumables shall not be used for any welding including repair welding and weld build-up.
- m. MIL-11018-M electrodes shall not be used for any welding including repair welding and weld build-up. Weld repair and weld build-up shall be accomplished using MIL-10718-M or MIL-100S electrodes.

B.3.6.1.1 Weld Repairs of Mill Defects Prior to Heat Treatment. Weld repairs of mill imperfections may be accomplished prior to heat treatment within the limitations of B.3.6.1 using an acceptable heat-treatable electrode.

B.3.6.2 Edge Defects. Visual laminar edge defects less than ¼ inch (6.4 mm) long are acceptable. Laminar edge defects ¼ inch (6.4 mm) long and over shall be explored by ultrasonics on the plate surface adjacent to the affected area. Edge defects that extend into the plate to the extent that they will result in rejectable defects according to the ultrasonic acceptance standards specified in B.3.7 shall be cause for rejection, unless an alternate ultrasonic acceptance standard is specified (see B.6.2). Laminar edge defect weld repairs shall be made using a NAVSEA approved weld procedure.

B.3.7 Internal Soundness and Thickness. Plates over ½ inch (13 mm) thick, unless otherwise specified (see B.6.2), shall be ultrasonically inspected for internal soundness in accordance with B.4.6.5.1 and ultrasonically measured for decimal thickness in accordance with B.4.6.5.2. Each Type II plate, and, when specified (see B.6.2), all plates, shall be ultrasonically inspected for internal soundness and ultrasonically measured for thickness. Plates over ½ inch (13 mm) thick not ultrasonically inspected or ultrasonically measured for decimal thickness shall be classified as Type I in accordance with B.1.2.

B.3.7.1 Recording of Thickness Measurements and Internal Soundness Results. Thickness measurements, mechanical and, where applicable, ultrasonic (see B.4.6.5.2), shall be prepared in accordance with the format shown on [Figure J-1](#). Unless alternate ultrasonic soundness inspection requirements are specified (see B.6.2), when internal soundness inspection is performed (see B.3.7), results shall be prepared in accordance with the format shown on [Figure A-5](#).

B.3.8 Applicable Fabrication Document. The applicable fabrication document shall be specified (see B.6.2) and shall cover the repair and the inspection of the base metal.

B.3.9 Dimensional Tolerances. Tolerances shall be as specified in B.3.9.1 through B.3.9.4.

B.3.9.1 Thickness, Weight, and Gauge. For plate ordered to decimal thickness, the maximum allowable variations in thickness measurements shall be as specified in [Table B-6](#) and [Table B-7](#). For plate ordered to a specific weight basis, the maximum allowable variations in weight and gauge shall be as specified in [Table B-8](#) (see B.6.2).

B.3.9.2 Flatness. Plates shall be flat within the tolerance limits specified in [Table B-9](#). The flatness, as specified in [Table B-9](#), shall be an overall flatness factor. This factor shall not apply to “kinks” or “waviness”. The waviness or kinking permitted shall be judged by laying a 3-foot (1-meter) straightedge across the affected edges. The maximum permissible deviation from the straightedge shall be ¼ inch (6.4 mm). When specified (see B.6.2), tighter requirements may be required.

B.3.9.3 Camber. Camber of the plates shall not exceed the tolerance limits specified in [Table B-10](#).

B.3.9.4 Size Tolerances. The width and length of the plates shall not vary in excess of the tolerances specified in [Table B-11](#) and [Table B-12](#).

B.3.10 Cleaning and Preservation of Plate Surfaces. Unless otherwise specified (see B.6.2), the surfaces of the plates shall be descaled and coated as specified in Appendix K.

B.3.11 Marking. Each plate shall be indentation stamped with heat number, plate number, type number, and the designation Grade HY-80 or HY-100. The primary (final) rolling direction of the plate with respect to the hot top of the ingot or the leading edge of the slab for continuous cast products shall be identified. The marking may be painted or stenciled in lieu of die stamped on plates ¼ inch (6.4 mm) thick and less. Where the plate number provides positive identification of the heat number, the heat number may be omitted from the markings. Material identification or layout indentations shall be made with low stress die stamps or other approved techniques.

B.3.12 Explosion Testing. Explosion testing is required as part of first article testing and is not required for conformance testing. Two explosion crack starter tests are required for first article testing. Both specimens shall conform to the crack starter configuration requirements on [Figure L-8](#) and meet the explosion crack starter requirements in Appendix L. When explosion bulge type testing is specified (see B.6.2), testing shall be in accordance with Appendix L and explosion bulge shots shall continue until a reduction in thickness of 16 percent for HY-80 or 14 percent for HY-100 is obtained on one or both sides.

T9074-BD-GIB-010/0300 Rev 2

Table B-6. Thickness Tolerances in Inches and Millimeters (Average) Over Ordered Thickness for Single Plate 2 Inches (51mm) and Under in Thickness. ^{1/}, ^{2/}

Specified Thickness, inches (mm)	Tolerance Over Ordered Thickness for Widths Given, inch (mm)												
	48 (1219) or under	48 (1219) to 60 (1524), exclusive	60 (1524) to 72 (1829), exclusive	72 (1829) to 84 (2134), exclusive	84 (2134) to 96 (2438), exclusive	96 (2438) to 108 (2743), exclusive	108 (2743) to 120 (3048), exclusive	120 (3048) to 132 (3353), exclusive	132 (3353) to 144 (3658), exclusive	144 (3658) to 168 (4267), exclusive	168 (4267) to 182 (4623), exclusive	182 (4623) and over	
¹ / ₄ (6.4)	0.015 (0.4)	0.015 (0.4)	0.021 (0.5)	0.021 (0.5)	0.027 (0.7)	0.027 (0.7)	0.035 (0.9)	---	---	---	---	---	
⁵ / ₁₆ (7.9)	0.015 (0.4)	0.015 (0.4)	0.021 (0.5)	0.027 (0.7)	0.027 (0.7)	0.027 (0.7)	0.035 (0.9)	0.042 (1.1)	---	---	---	---	
³ / ₈ (9.5)	0.015 (0.4)	0.015 (0.4)	0.021 (0.5)	0.027 (0.7)	0.027 (0.7)	0.035 (0.9)	0.035 (0.9)	0.042 (1.1)	---	---	---	---	
⁷ / ₁₆ (11.1)	0.015 (0.4)	0.015 (0.4)	0.021 (0.5)	0.027 (0.7)	0.027 (0.7)	0.035 (0.9)	0.042 (1.1)	0.042 (1.1)	0.052 (1.3)	---	---	---	
¹ / ₂ (12.7)	0.021 (0.5)	0.021 (0.5)	0.021 (0.5)	0.027 (0.7)	0.027 (0.7)	0.035 (0.9)	0.042 (1.1)	0.042 (1.1)	0.052 (1.3)	0.062 (1.6)	---	---	
⁹ / ₁₆ (14.3)	0.021 (0.5)	0.021 (0.5)	0.027 (0.7)	0.027 (0.7)	0.027 (0.7)	0.035 (0.9)	0.042 (1.1)	0.052 (1.3)	0.052 (1.3)	0.062 (1.6)	---	---	
⁵ / ₈ (15.9)	0.027 (0.7)	0.027 (0.7)	0.027 (0.7)	0.027 (0.7)	0.027 (0.7)	0.035 (0.9)	0.042 (1.1)	0.052 (1.3)	0.052 (1.3)	0.062 (1.6)	0.069 (1.8)	0.076 (1.9)	
¹¹ / ₁₆ (17.5)	0.027 (0.7)	0.027 (0.7)	0.027 (0.7)	0.027 (0.7)	0.027 (0.7)	0.035 (0.9)	0.042 (1.1)	0.052 (1.3)	0.052 (1.3)	0.062 (1.6)	0.069 (1.8)	0.076 (1.9)	
³ / ₄ (19.1)	0.027 (0.7)	0.027 (0.7)	0.027 (0.7)	0.027 (0.7)	0.035 (0.9)	0.035 (0.9)	0.042 (1.1)	0.052 (1.3)	0.068 (1.7)	0.075 (1.9)	0.077 (2.0)	0.086 (2.2)	
¹³ / ₁₆ (20.6)	0.027 (0.7)	0.035 (0.9)	0.035 (0.9)	0.035 (0.9)	0.035 (0.9)	0.042 (1.1)	0.052 (1.3)	0.052 (1.3)	0.068 (1.7)	0.075 (1.9)	0.085 (2.2)	0.095 (2.4)	
⁷ / ₈ (22.2)	0.035 (0.9)	0.035 (0.9)	0.035 (0.9)	0.035 (0.9)	0.042 (1.1)	0.042 (1.1)	0.052 (1.3)	0.062 (1.6)	0.068 (1.7)	0.075 (1.9)	0.085 (2.2)	0.095 (2.4)	
¹⁵ / ₁₆ (23.8)	0.035 (0.9)	0.035 (0.9)	0.035 (0.9)	0.035 (0.9)	0.042 (1.1)	0.042 (1.1)	0.052 (1.3)	0.062 (1.6)	0.075 (1.9)	0.085 (2.2)	0.093 (2.4)	0.107 (2.7)	
1 (25.4)	0.035 (0.9)	0.035 (0.9)	0.042 (1.1)	0.042 (1.1)	0.042 (1.1)	0.042 (1.1)	0.052 (1.3)	0.062 (1.6)	0.075 (1.9)	0.085 (2.2)	0.093 (2.4)	0.107 (2.7)	
1 ¹ / ₁₆ (27.0)	0.035 (0.9)	0.035 (0.9)	0.042 (1.1)	0.042 (1.1)	0.042 (1.1)	0.052 (1.3)	0.052 (1.3)	0.062 (1.6)	0.075 (1.9)	0.085 (2.2)	0.096 (2.4)	0.107 (2.7)	
1 ¹ / ₈ (28.6)	0.042 (1.1)	0.042 (1.1)	0.042 (1.1)	0.042 (1.1)	0.042 (1.1)	0.052 (1.3)	0.052 (1.3)	0.068 (1.7)	0.075 (1.9)	0.085 (2.2)	0.096 (2.4)	0.107 (2.7)	
1 ³ / ₁₆ (30.2)	0.042 (1.1)	0.042 (1.1)	0.052 (1.3)	0.052 (1.3)	0.052 (1.3)	0.052 (1.3)	0.062 (1.6)	0.075 (1.9)	0.085 (2.2)	0.095 (2.4)	0.102 (2.6)	0.117 (3.0)	
1 ¹ / ₄ (31.8)	0.042 (1.1)	0.042 (1.1)	0.052 (1.3)	0.052 (1.3)	0.052 (1.3)	0.062 (1.6)	0.062 (1.6)	0.075 (1.9)	0.085 (2.2)	0.095 (2.4)	0.106 (2.7)	0.117 (3.0)	
1 ⁵ / ₁₆ (33.3)	0.042 (1.1)	0.042 (1.1)	0.052 (1.3)	0.052 (1.3)	0.052 (1.3)	0.062 (1.6)	0.062 (1.6)	0.075 (1.9)	0.095 (2.4)	0.105 (2.7)	0.115 (2.9)	0.125 (3.2)	
1 ³ / ₈ (34.9)	0.047 (1.2)	0.052 (1.3)	0.052 (1.3)	0.052 (1.3)	0.052 (1.3)	0.062 (1.6)	0.068 (1.7)	0.085 (2.2)	0.095 (2.4)	0.105 (2.7)	0.115 (2.9)	0.125 (3.2)	
1 ⁷ / ₁₆ (36.5)	0.047 (1.2)	0.052 (1.3)	0.062 (1.6)	0.062 (1.6)	0.062 (1.6)	0.062 (1.6)	0.075 (1.9)	0.085 (2.2)	0.105 (2.7)	0.115 (2.9)	0.125 (3.2)	0.135 (3.4)	
1 ¹ / ₂ (38.1)	0.052 (1.3)	0.052 (1.3)	0.062 (1.6)	0.062 (1.6)	0.062 (1.6)	0.068 (1.7)	0.075 (1.9)	0.085 (2.2)	0.105 (2.7)	0.115 (2.9)	0.125 (3.2)	0.135 (3.4)	
1 ⁹ / ₁₆ (39.7)	0.052 (1.3)	0.052 (1.3)	0.062 (1.6)	0.062 (1.6)	0.062 (1.6)	0.068 (1.7)	0.075 (1.9)	0.095 (2.4)	0.105 (2.7)	0.130 (3.3)	0.145 (3.7)	0.160 (4.1)	
1 ⁵ / ₈ (41.3)	0.062 (1.6)	0.062 (1.6)	0.062 (1.6)	0.062 (1.6)	0.062 (1.6)	0.075 (1.9)	0.085 (2.2)	0.095 (2.4)	0.115 (2.9)	0.130 (3.3)	0.145 (3.7)	0.160 (4.1)	
1 ¹¹ / ₁₆ (42.9)	0.062 (1.6)	0.062 (1.6)	0.068 (1.7)	0.068 (1.7)	0.068 (1.7)	0.075 (1.9)	0.085 (2.2)	0.105 (2.7)	0.115 (2.9)	0.130 (3.3)	0.145 (3.7)	0.160 (4.1)	
1 ³ / ₄ (44.5)	0.062 (1.6)	0.062 (1.6)	0.068 (1.7)	0.068 (1.7)	0.068 (1.7)	0.075 (1.9)	0.085 (2.2)	0.105 (2.7)	0.125 (3.2)	0.145 (3.7)	0.165 (4.2)	0.185 (4.7)	
1 ¹³ / ₁₆ (46.0)	0.062 (1.6)	0.062 (1.6)	0.075 (1.9)	0.075 (1.9)	0.075 (1.9)	0.085 (2.2)	0.095 (2.4)	0.105 (2.7)	0.125 (3.2)	0.145 (3.7)	0.165 (4.2)	0.185 (4.7)	
1 ⁷ / ₈ (47.6)	0.062 (1.6)	0.062 (1.6)	0.075 (1.9)	0.075 (1.9)	0.075 (1.9)	0.085 (2.2)	0.095 (2.4)	0.115 (2.9)	0.125 (3.2)	0.145 (3.7)	0.165 (4.2)	0.185 (4.7)	
1 ¹⁵ / ₁₆ (49.2)	0.068 (1.7)	0.068 (1.7)	0.075 (1.9)	0.075 (1.9)	0.075 (1.9)	0.085 (2.2)	0.095 (2.4)	0.115 (2.9)	0.141 (3.6)	0.157 (4.0)	0.174 (4.4)	0.190 (4.8)	
2 (50.8)	0.068 (1.7)	0.068 (1.7)	0.075 (1.9)	0.075 (1.9)	0.075 (1.9)	0.085 (2.2)	0.095 (2.4)	0.115 (2.9)	0.141 (3.6)	0.157 (4.0)	0.174 (4.4)	0.190 (4.8)	

NOTES:
^{1/} Tolerance under specified thickness, 0.01 inch (0.3 mm).
^{2/} For intermediate thickness, the tolerance of the closer specified gauge shall apply. In case of mid-point, the tolerance for the lower gauge or interpolated value shall apply.

Table B-7. Thickness Tolerances in Inches (mm) (Average) Over Ordered Thickness for a Single Plate over 2 Inches (51 mm) Thick when Ordered to Thickness in Inches (mm). 1/, 2/

Specified Thickness, inches (mm)	Tolerances Over Specified Thickness for Widths Given					
	To 36 (914), exclusive	36 (914) to 60 (1524), exclusive	60 (1524) to 84 (2134), exclusive	84 (2134) to 120 (3048), exclusive	120 (3048) to 132 (3353), exclusive	132 (3353) and over
Over 2 (50.8) to 3 (76.2), exclusive	0.063 (1.6)	0.094 (2.4)	0.109 (2.8)	0.125 (3.2)	0.125 (3.2)	0.141 (3.6)
3 (76.2) to 4 (101.6), exclusive	0.078 (2.0)	0.094 (2.4)	0.109 (2.8)	0.125 (3.2)	0.125 (3.2)	0.141 (3.6)
4 (101.6) to 6 (152.4), exclusive	0.094 (2.4)	0.125 (3.2)	0.141 (3.6)	0.156 (4.0)	0.156 (4.0)	0.172 (4.4)
6 (152.4) to 8 (203.2), exclusive	0.109 (2.8)	0.125 (3.2)	0.156 (4.0)	0.172 (4.4)	0.172 (4.4)	----

NOTES:

1/ Tolerance under specified thickness, 0.01 inch (0.3 mm).

2/ For intermediate thickness, the tolerance of the closer gauge shall apply. In case of mid-point, the tolerance for the lower gauge or interpolated value shall apply.

T9074-BD-GIB-010/0300 Rev 2

Table B-8. Allowable Variation in Weight and Gauge for Plates Specified on a Weight Basis (Applicable to Single Plates).

Allowable Under Gauge at Edge for Widths Given, inches (mm)									
Specified Weight, lb/ft ² [kg/m ²] {Thickness, inch (mm)}	Up to 66 (1676), inclusive	Over 66 (1676) to 80 (2032), inclusive	Over 80 (2032) to 90 (2286), inclusive	Over 90 (2286) to 100 (2540), inclusive	Over 100 (2540) to 115 (2921), inclusive	Over 115 (2921) to 135 (3429), inclusive	Over 135 (3429) to 150 (3810), inclusive	Over 150 (3810) to 168 (4267), inclusive	Over 168 (4267)
	Percent	Percent	Percent	Percent	Percent	Percent	Percent	Percent	Percent
To 20.4 [100], exclusive {½ (13)}	6	6	8	8	8	8	8	8	8
20.4 [100] to 25.5 [125], exclusive {½ (13) to ⅝ (16)}	3.5	4	4.5	5	5.5	6.5	6.5	6.5	6.5
25.5 [125] to 30.6 [149], exclusive {⅝ (16) to ¾ (19)}	3.5	4	4.5	5	5.5	6	6	6	6
30.6 [149] to 40.8 [199], exclusive {¾ (19) to 1 (25)}	3	3	3.5	4	4	4.5	5	5.5	6
40.8 [199] and over {1 (25)}	3	3	3	3	3	3.5	4	4.5	5
Allowable Weight Tolerance for Widths Given, inches (mm)									
Specified Weight, lb/ft ² [kg/m ²] {Thickness, inch (mm)}	Up to 150 (3810), inclusive		Over 150 (3810) to 168 (4267), inclusive		Over 168 (4267)				
	Percent		Percent		Percent				
	Over	Under	Over	Under	Over	Under			
To 20.4 [100], exclusive {½ (13)}	8	10	---	---	---	---			
20.4 [100] to 25.5 [125], exclusive {½ (13) to ⅝ (16)}	2	4	---	---	---	---			
25.5 [125] to 30.6 [149], exclusive {⅝ (16) to ¾ (19)}	2	4	---	---	---	---			
30.6 [149] to 40.8 [199], exclusive {¾ (19) to 1 (25)}	2	3.5	3	4	3	4			
40.8 [199] and over {1 (25)}	2	3	2	3	3	4			

Table B-9. Flatness Tolerances for Plates Ordered on a lb/ft² [kg/m²] or Inch (mm) Basis. 1/, 2/, 3/, 4/

Specified Thickness, inches (mm)	Specified Weight, lb/ft ² [kg/m ²]	Flatness Tolerance for Specified Widths, inches (mm)										
		Up to 36 (914), exclusive	36 (914) to 48 (1219), exclusive	48 (1219) to 60 (1524), exclusive	60 (1524) to 72 (1829), exclusive	72 (1829) to 84 (2134), exclusive	84 (2134) to 96 (2438), exclusive	96 (2438) to 108 (2743), exclusive	108 (2743) to 120 (3048), exclusive	120 (3048) to 144 (3658), exclusive	144 (3658) to 168 (4267), exclusive	168 (4267) and over
To ¼ (6), exclusive	To 10.2 [49.8], exclusive	¹³ / ₁₆ (21)	1⁄8 (29)	1 ³ / ₈ (35)	1⁄8 (48)	2 (51)	2¼ (57)	2 ³ / ₈ (60)	2 ⁵ / ₈ (67)	2¾ (70)	---	---
¼ (6) to ³ / ₈ (10), exclusive	10.2 [49.8] to 15.3 [74.7], exclusive	³ / ₄ (19)	¹⁵ / ₁₆ (24)	1⁄8 (29)	1 ³ / ₈ (35)	1¾ (45)	1⁄8 (48)	2 (51)	2¼ (57)	2 ³ / ₈ (60)	---	---
³ / ₈ (10) to ½ (13), exclusive	15.3 [74.7] to 20.4 [99.6], exclusive	³ / ₄ (19)	7⁄8 (22)	¹⁵ / ₁₆ (24)	¹⁵ / ₁₆ (24)	1½ (29)	1 ⁵ / ₁₆ (33)	1½ (38)	1 ⁵ / ₈ (41)	1⁄8 (48)	2¾ (70)	3 ¹ / ₈ (79)
½ (13) to ¾ (19), exclusive	20.4 [99.6] to 30.6 [149.4], exclusive	⁵ / ₈ (16)	³ / ₄ (19)	¹³ / ₁₆ (21)	7⁄8 (22)	1 (25)	1⁄8 (29)	1¼ (32)	1 ³ / ₈ (35)	1 ⁵ / ₈ (41)	2¼ (57)	3 (76)
¾ (19) to 1 (25), exclusive	30.6 [149.4] to 40.8 [199.2], exclusive	⁵ / ₈ (16)	³ / ₄ (19)	7⁄8 (22)	7⁄8 (22)	¹⁵ / ₁₆ (24)	1 (25)	1⁄8 (29)	1 ⁵ / ₁₆ (33)	1½ (38)	2 (51)	2 ⁵ / ₈ (67)
1 (25) to 2 (51), exclusive	40.8 [199.2] to 81.6 [398.4], exclusive	⁹ / ₁₆ (14)	⁵ / ₈ (16)	³ / ₄ (19)	¹³ / ₁₆ (21)	7⁄8 (22)	¹⁵ / ₁₆ (24)	1 (25)	1 (25)	1 (25)	1 ⁵ / ₈ (41)	2¼ (57)
2 (51) to 4 (102), exclusive	81.6 [398.4] to 163.2 [796.8], exclusive	½ (13)	⁹ / ₁₆ (14)	¹¹ / ₁₆ (18)	³ / ₄ (19)	³ / ₄ (19)	³ / ₄ (19)	³ / ₄ (19)	³ / ₄ (19)	7⁄8 (22)	1 (25)	1¼ (32)
4 (102) to 6 (152), exclusive	163.2 [796.8] to 244.8 [1195], exclusive	⁹ / ₁₆ (14)	¹¹ / ₁₆ (18)	³ / ₄ (19)	³ / ₄ (19)	7⁄8 (22)	7⁄8 (22)	¹⁵ / ₁₆ (24)	1⁄8 (29)	1¼ (32)	1¼ (32)	1½ (38)
6 (152) to 8 (203), exclusive	244.8 [1195] to 326.4 [1594], exclusive	⁵ / ₈ (16)	³ / ₄ (19)	³ / ₄ (19)	¹⁵ / ₁₆ (24)	1 (25)	1⁄8 (29)	1¼ (32)	1 ⁵ / ₁₆ (33)	1½ (38)	1½ (38)	1½ (38)
8 (203)	326.4 [1594]	³ / ₄ (19)	¹³ / ₁₆ (21)	¹⁵ / ₁₆ (24)	1 (25)	1⁄8 (29)	1¼ (32)	1 ⁵ / ₁₆ (33)	1 ³ / ₈ (35)	1½ (38)	1½ (38)	1½ (38)

NOTES:

1/ Flatness tolerances for length and width. The longer dimension specified is considered the length. Variation from a flat surface along the length shall not exceed the tabular amount for the specified width in any 12 feet (4 meters) of length.

2/ When the longer dimension is under 36 inches (1 meter), the variation in flatness shall not exceed ¼ inch (6.4 mm).

3/ The above table and notes also cover the flatness tolerances of circular and sketch plates, based on the maximum dimensions of those plates.

4/ Plate shall be tested without any other constraint.

T9074-BD-GIB-010/0300 Rev 2

Table B-10. Camber Tolerances for Plates Ordered on a lb/ft² [kg/m²] or Inch (mm) Basis. 1/

Specified Weight, lb/ft ² [kg/m ²]	Thickness, inches (mm)	Width, inches (mm)	Camber Tolerance for Thickness and Width Given		
To 81.6 [398], inclusive	To 2 (51), inclusive	All	1/8 inch	X	<u>length (feet)</u> 5
			3 mm	X	<u>length (meters)</u> 1.524
----	Over 2 (51) to 8 (203), exclusive	To 30 (762), inclusive	3/16 inch	X	<u>length (feet)</u> 5
			5 mm	X	<u>length (meters)</u> 1.524
----	Over 2 (51) to 8 (203), exclusive	Over 30 (762) to 60 (1524), inclusive	1/4 inch	X	<u>length (feet)</u> 5
			6.4 mm	X	<u>length (meters)</u> 1.524
NOTES:					
1/ Plate shall be tested without any other constraint.					

Table B-11. Width and Length Tolerances for Sheared Plates 1 Inch (25 mm) Thick or Less. 1/

Specified Dimensions, inches (mm)		Maximum Permissible Variations Over Specific Width and Length for Weight or Thickness Given					
Width	Length	To $\frac{3}{8}$ inch (10 mm), exclusive		$\frac{3}{8}$ to $\frac{5}{8}$ inch (10 to 16 mm), exclusive		$\frac{5}{8}$ to 1 inch (16 to 25 mm), exclusive	
		Under 15.3 lb/ft ² [74.7 kg/m ²], exclusive		15.3 to 25.5 lb/ft ² [74.7 to 124.5 kg/m ²], exclusive		25.5 to 40.8 lb/ft ² [124.5 to 199.2 kg/m ²], exclusive	
		Width, inch (mm)	Length, inch (mm)	Width, inch (mm)	Length, inch (mm)	Width, inch (mm)	Length, inch (mm)
To 60 (1524), exclusive	To 120 (3048), exclusive	$\frac{3}{8}$ (10)	$\frac{1}{2}$ (13)	$\frac{7}{16}$ (11)	$\frac{5}{8}$ (16)	$\frac{1}{2}$ (13)	$\frac{3}{4}$ (19)
60 (1524) to 84 (2134), exclusive		$\frac{7}{16}$ (11)	$\frac{5}{8}$ (16)	$\frac{1}{2}$ (13)	$\frac{11}{16}$ (18)	$\frac{5}{8}$ (16)	$\frac{7}{8}$ (22)
84 (2134) to 108 (2743), exclusive		$\frac{1}{2}$ (13)	$\frac{3}{4}$ (19)	$\frac{5}{8}$ (16)	$\frac{7}{8}$ (22)	$\frac{3}{4}$ (19)	1 (25)
108 (2743) and over		$\frac{5}{8}$ (16)	$\frac{7}{8}$ (22)	$\frac{3}{4}$ (19)	1 (25)	$\frac{7}{8}$ (22)	$1\frac{1}{8}$ (29)
To 60 (1524), exclusive	120 (3048) to 240 (6096), exclusive	$\frac{3}{8}$ (10)	$\frac{3}{4}$ (19)	$\frac{1}{2}$ (13)	$\frac{7}{8}$ (22)	$\frac{5}{8}$ (16)	1 (25)
60 (1524) to 84 (2134), exclusive		$\frac{1}{2}$ (13)	$\frac{3}{4}$ (19)	$\frac{5}{8}$ (16)	$\frac{7}{8}$ (22)	$\frac{3}{4}$ (19)	1 (25)
84 (2134) to 108 (2743), exclusive		$\frac{9}{16}$ (14)	$\frac{7}{8}$ (22)	$\frac{11}{16}$ (18)	$\frac{15}{16}$ (24)	$\frac{13}{16}$ (21)	$1\frac{1}{8}$ (29)
108 (2743) and over		$\frac{5}{8}$ (16)	1 (25)	$\frac{3}{4}$ (19)	$1\frac{3}{16}$ (30)	$\frac{7}{8}$ (22)	$1\frac{1}{4}$ (32)
To 60 (1524), exclusive	240 (6096) to 360 (9144), exclusive	$\frac{3}{8}$ (10)	$1\frac{1}{16}$ (27)	$\frac{1}{2}$ (13)	$1\frac{3}{16}$ (30)	$\frac{5}{8}$ (16)	$1\frac{5}{16}$ (33)
60 (1524) to 84 (2134), exclusive		$\frac{1}{2}$ (13)	$1\frac{1}{16}$ (27)	$\frac{5}{8}$ (16)	$1\frac{3}{16}$ (30)	$\frac{3}{4}$ (19)	$1\frac{5}{16}$ (33)
84 (2134) to 108 (2743), exclusive		$\frac{9}{16}$ (14)	$1\frac{1}{16}$ (27)	$\frac{11}{16}$ (18)	$1\frac{3}{16}$ (30)	$\frac{7}{8}$ (22)	$1\frac{7}{16}$ (37)
108 (2743) and over		$\frac{11}{16}$ (18)	$1\frac{3}{16}$ (30)	$\frac{7}{8}$ (22)	$1\frac{5}{16}$ (33)	1 (25)	$1\frac{7}{16}$ (37)
To 60 (1524), exclusive	360 (9144) to 480 (12192), exclusive	$\frac{7}{16}$ (11)	$1\frac{3}{16}$ (30)	$\frac{1}{2}$ (13)	$1\frac{5}{16}$ (33)	$\frac{5}{8}$ (16)	$1\frac{7}{16}$ (37)
60 (1524) to 84 (2134), exclusive		$\frac{1}{2}$ (13)	$1\frac{3}{16}$ (33)	$\frac{5}{8}$ (16)	$1\frac{7}{16}$ (37)	$\frac{3}{4}$ (19)	$1\frac{9}{16}$ (40)
84 (2134) to 108 (2743), exclusive		$\frac{9}{16}$ (14)	$1\frac{3}{16}$ (33)	$\frac{3}{4}$ (19)	$1\frac{7}{16}$ (37)	$\frac{7}{8}$ (22)	$1\frac{9}{16}$ (40)
108 (2743) and over		$\frac{3}{4}$ (19)	$1\frac{7}{16}$ (37)	$\frac{7}{8}$ (22)	$1\frac{9}{16}$ (40)	1 (25)	$1\frac{11}{16}$ (43)
To 60 (1524), exclusive	480 (12192) to 600 (15240), exclusive	$\frac{7}{16}$ (11)	$1\frac{3}{8}$ (35)	$\frac{1}{2}$ (13)	$1\frac{5}{8}$ (41)	$\frac{5}{8}$ (16)	$1\frac{3}{4}$ (45)
60 (1524) to 84 (2134), exclusive		$\frac{1}{2}$ (13)	$1\frac{1}{2}$ (38)	$\frac{5}{8}$ (16)	$1\frac{5}{8}$ (41)	$\frac{3}{4}$ (19)	$1\frac{3}{4}$ (45)
84 (2134) to 108 (2743), exclusive		$\frac{5}{8}$ (16)	$1\frac{1}{2}$ (38)	$\frac{3}{4}$ (19)	$1\frac{5}{8}$ (41)	$\frac{7}{8}$ (22)	$1\frac{3}{4}$ (45)
108 (2743) and over		$\frac{3}{4}$ (19)	$1\frac{5}{8}$ (41)	$\frac{7}{8}$ (22)	$1\frac{3}{4}$ (45)	1 (25)	$1\frac{7}{8}$ (48)
To 60 (1524), exclusive	600 (15240) to 720 (18288), exclusive	$\frac{1}{2}$ (13)	$1\frac{7}{8}$ (48)	$\frac{5}{8}$ (16)	2 (51)	$\frac{3}{4}$ (19)	2 (51)
60 (1524) to 84 (2134), exclusive		$\frac{5}{8}$ (16)	$1\frac{7}{8}$ (48)	$\frac{3}{4}$ (19)	2 (51)	$\frac{7}{8}$ (22)	2 (51)
84 (2134) to 108 (2743), exclusive		$\frac{5}{8}$ (16)	$1\frac{7}{8}$ (48)	$\frac{3}{4}$ (19)	2 (51)	$\frac{7}{8}$ (22)	2 (51)
108 (2743) and over		$\frac{7}{8}$ (22)	$1\frac{7}{8}$ (48)	1 (25)	$2\frac{1}{8}$ (54)	$1\frac{1}{8}$ (29)	$2\frac{3}{8}$ (60)
To 60 (1524), exclusive	720 (18288) and over	$\frac{9}{16}$ (14)	$2\frac{1}{8}$ (54)	$\frac{3}{4}$ (19)	$2\frac{1}{4}$ (57)	$\frac{7}{8}$ (22)	$2\frac{3}{8}$ (60)
60 (1524) to 84 (2134), exclusive		$\frac{3}{4}$ (19)	$2\frac{1}{8}$ (54)	$\frac{7}{8}$ (22)	$2\frac{1}{4}$ (57)	1 (25)	$2\frac{3}{8}$ (60)
84 (2134) to 108 (2743), exclusive		$\frac{3}{4}$ (19)	$2\frac{1}{8}$ (54)	$\frac{7}{8}$ (22)	$2\frac{1}{4}$ (57)	1 (25)	$2\frac{3}{8}$ (60)
108 (2743) and over		1 (25)	$2\frac{1}{8}$ (54)	$1\frac{1}{8}$ (29)	$2\frac{1}{2}$ (64)	$1\frac{1}{4}$ (32)	$2\frac{5}{8}$ (67)

NOTES:

1/ Maximum permissible variation under specified width and length is $\frac{1}{4}$ inch (6.4 mm).

T9074-BD-GIB-010/0300 Rev 2

Table B-12. Width and Length Tolerances for Gas-Cut Rectangular Plates. 1/

Specified Thicknesses, inches (mm)	Tolerances Over for All Specified Widths or Lengths, inches (mm)
To 2 (51), exclusive	$\frac{3}{4}$ (19)
2 (51) to 4 (102), exclusive	1 (25)
4 (102) to 6 (152), exclusive	$1\frac{1}{8}$ (29)
6 (152) to 8 (203), exclusive	$1\frac{5}{16}$ (33)
NOTES:	
<u>1/</u> Maximum permissible variation under specified width and length is $\frac{1}{4}$ inch (6.4 mm).	

B.4 VERIFICATION.

B.4.1 Responsibility for Inspection. See 4.1.

B.4.2 Classification of Inspections. The inspection requirements specified herein are classified as follows:

- a. First article inspection (see B.4.3).
- b. Conformance inspection (see B.4.4).

B.4.3 First Article Inspection. First article inspection shall consist of the examinations and tests specified in [Table B-13](#) (see B.6.4, 4.3, and Appendix L). Specimens for first article testing inspection shall be located and tested as specified on [Figure B-1](#) and [Figure B-2](#), unless otherwise specified (see B.6.2). At a minimum, plate thickness of 1 inch (25 mm), 2 inches (51 mm), and the thickest gauge to be produced at the mill shall be tested. Unless otherwise specified (see B.6.2), HY-80 and HY-100 shall be tested separately. A first article inspection report shall be prepared as specified in 3.1.

Table B-13. First Article and Conformance Inspection Requirements.

Examination and Tests	Requirement	Test Method	First Article	Conformance
Chemical analysis	B.3.2	4.5.1 and B.4.6.1	X	X
Tensile properties	B.3.3	4.5.2 and B.4.6.2	X	X
Explosion	B.3.12	4.5.5	X	----
Impact Properties				
Charpy V-notch	B.3.4	4.5.3 and B.4.6.3	X	X
Dynamic tear	B.3.4	4.5.4 and B.4.6.3	X	X
Examination				
Surface quality	B.3.6	B.4.5	X	X
Dimensional	B.3.9	B.4.6.4	X	X
Internal soundness	B.3.7	B.4.6.4	X	X

B.4.4 Conformance Inspection. Conformance inspection (i.e., inspections of production lots) shall consist of the examinations and tests specified in [Table B-13](#).

B.4.4.1 Lot Definitions.

B.4.4.1.1 Lot for Chemical or Spectrographic Analysis. See 4.4.1.1.

B.4.4.1.2 Lot for Tension Tests. Each plate as-heat-treated shall constitute a lot.

B.4.4.1.3 Lot for Impact Tests. Each plate as-heat-treated shall constitute a lot.

B.4.4.1.4 Lot for Examination and Inspections. For purposes of visual and dimensional examination and for nondestructive inspection, each plate submitted for final inspection shall constitute a lot.

B.4.4.2 Sampling for Conformance Inspection.

B.4.4.2.1 Location of Test Specimens in Plate. The specimens shall be located as shown on [Figure B-3](#) and [Figure B-4](#). [Figure B-3](#) shall be used when the final direction of rolling is parallel to the longitudinal axis of the ingot. [Figure B-4](#) shall be used when the final rolling direction is parallel to the transverse axis of the ingot. The final direction of rolling is the direction of rolling in which the greatest reduction ratio was achieved. The specimens shall be separated by not less than three times the plate thickness or 4 inches (102 mm), whichever is less, from the as-heat-treated edge of the plate.

B.4.4.2.2 Sampling for Chemical or Spectrographic Analysis. Solid samples for chemical or spectrographic analysis shall be taken from mid-thickness at the top, center position (see [Figure B-3](#) and [Figure B-4](#)) of the top plate from each ingot in each lot. For continuous cast slabs, specimens shall be taken from either the Charpy V-notch or dynamic tear specimens at mid-thickness from one location in one plate in each lot.

B.4.4.2.3 Sampling for Tensile Test. After final heat treatment of the lot, including any stress relief treatment, one top transverse tensile specimen and one bottom transverse tensile test specimen shall be taken from each plate. The tensile specimen shall be located as shown on [Figure B-3](#) and [Figure B-4](#) and one surface of the specimen shall be at a depth as near as practicable to T/2 below the surface, where T is the as-heat-treated thickness of the plate. In addition, for plate thicknesses of 3 inches or greater, a through-thickness tensile specimen shall be taken from the same location as the sample for chemical analysis (see B.4.4.2.2).

B.4.4.2.4 Sampling for Impact Test. Samples for impact test shall be taken after final heat treatment of the lot, including any stress relief treatment at the locations indicated in [Figure B-3](#) and [Figure B-4](#) (see B.4.4.2.1). Dynamic tear tests shall be performed on plates over $\frac{5}{8}$ inch (16 mm) thick, Charpy V-notch tests on plates over $\frac{1}{2}$ inch (13 mm) through $\frac{5}{8}$ inch (16 mm), and no tests shall be required for plates $\frac{1}{2}$ inch (13 mm) and under in thickness.

B.4.4.2.4.1 Charpy V-Notch Specimen. From the plates selected, three transverse Charpy V-notch test specimens shall be taken from each location for each test temperature. The specimens shall be so located in the thickness of the plate, such that, for 20.4 lb/ft² [100 kg/m²] ($\frac{1}{2}$ inch or 13 mm thick) to 35.7 lb/ft² [174 kg/m²] ($\frac{7}{8}$ inch or 22 mm thick), the plate surface (after light machining) shall be one face of the specimen. For plates 35.7 lb/ft² [174 kg/m²] ($\frac{7}{8}$ inch or 22 mm thick) and heavier, the centerline of the plate shall be in one face of the specimen. The notch shall be perpendicular to the plate surface.

T9074-BD-GIB-010/0300 Rev 2

B.4.4.2.4.2 Dynamic Tear Specimen. In the case of dynamic tear testing from the plates selected, two transverse dynamic tear test specimens shall be taken from each location for each test temperature. The dynamic tear specimens shall be located in the thickness of the plate, such that the centerline of the plate shall be the centerline of the specimen. The notch shall be perpendicular to the plate surfaces.

B.4.4.2.5 Sampling for Mechanical Properties After Simulated Stress Relief. When specified (see B.6.2), sample material (see B.4.4.2.3 and B.4.4.2.4) shall be subjected to simulated stress relief operations after quenching and tempering, but prior to testing for conformance to the mechanical property requirements in B.3.3 and B.3.4. The sample material shall not be removed from the plate prior to quenching and tempering. The total time at temperature and cooling rate for the simulated stress relief operations shall be as specified (see B.6.2). The cooling rate and the maximum and minimum time at temperature used on the sample material shall be incorporated in the test documentation, along with the destructive and nondestructive test results.

B.4.4.2.6 Thermal Buffer Pad Requirements. Where the crop is insufficient to obtain test specimens, thermal buffer pads in accordance with ASTM A20 shall be used to maintain the proper distance from the heat treated edge of the plate.

B.4.4.2.7 Marking of Test Specimens. The test specimens shall be marked to ensure positive identification of the lot being tested.

B.4.5 Visual Examination. Each plate shall be examined visually and shall meet the requirements of B.3.6. With respect to coating applications, the number of plates subject to paint film thickness measurements should be held to the minimum necessary to assure continued satisfactory performance. Paint thickness measurements shall be in accordance with Appendix K.

B.4.6 Test Procedures. See [Table B-13](#) and 4.5.

B.4.6.1 Chemical or Spectrographic Analysis. If the sample from the topmost plates fails to meet the requirements, all plates from the heat in question shall be rejected. Samples from rejected plates may be analyzed separately, provided the samples are taken in the specified locations, and those plates which conform in chemical composition to B.3.2 will be accepted.

B.4.6.1.1 Continuous Cast Slabs. The sample selected in accordance with B.4.4.2.2 shall be analyzed to determine conformance with the requirements of B.3.2. If the sample fails to meet the requirements, all plates from the heat shall be rejected. Plates may be analyzed separately provided the samples are taken in the specified locations, and those plates which conform in chemical composition to B.3.2 will be accepted.

B.4.6.2 Tensile Tests. See 4.5.2 and B.3.3.

B.4.6.3 Impact Toughness.

B.4.6.3.1 Charpy V-Notch Test. Conformance inspection test specimens shall be tested with coolant temperatures as specified in [Table B-4](#).

B.4.6.3.2 Percent Shear Fracture. Percent shear fracture shall be determined in accordance with ASTM A370.

B.4.6.3.3 Dynamic Tear Test. See 4.5.4 and B.3.4.

B.4.6.4 Gauging. Each plate shall be measured with a calibrated micrometer at three evenly distributed points along each longitudinal edge and at two evenly distributed points along each transverse edge.

B.4.6.5 Ultrasonic Examination. The requirements of T9074-AS-GIB-010/271 shall apply for the qualification of ultrasonic testing personnel, qualification and calibration of equipment, qualification of procedures, and reporting of test results. The scanning surface of the plate may have one coat each of pretreatment and primer.

B.4.6.5.1 Ultrasonic Soundness. Unless alternate ultrasonic soundness inspection requirements are specified (see B.6.2), examinations shall be performed in accordance with ASTM A435, including the Supplementary Requirements of S1, and shall meet the acceptance standards stated therein.

B.4.6.5.2 Ultrasonic Thickness. Examinations shall be performed in accordance with Appendix J and meet the requirements of [Table B-5](#) and [Table B-6](#) herein. When plate is specified on a lb/ft² basis, ultrasonic inspection for thickness is not required.

B.4.6.6 Documentation. Records of thickness measurements and soundness (see B.3.7.1) shall be prepared and transmitted with the material.

B.5 PACKAGING.

See Chapter 5.

B.6 NOTES.

B.6.1 Intended Use. Grade HY-80 and Grade HY-100, sheared or gas-cut, alloy steel plate, are intended for use in critical structural applications where a notch-tough, high-strength material is required. The use of these steels in fabricated structure or equipment entails much more than a material specification, and caution is advised in the areas of welding, fabrication, and nondestructive testing.

B.6.2 Acquisition Requirements. Acquisition documents must specify the following:

- a. Title, number, and date of this specification.
- b. Sizes and number of plates required.
- c. Type and grade required (see B.1.2).
- d. If plates are required to be composed of all virgin raw material (see B.3.1).
- e. If minimum ultimate tensile strength is required, the minimum value must be specified (see B.3.3.1 and [Table B-2](#)).
- f. When a simulated stress relief sample is required. If required, the number of thermal cycles, the heating and cooling rates, and the time at temperature must be specified (see B.3.5.2 and B.4.4.2.5).
- g. When weld repair after final heat treatment is prohibited or shall be conducted in accordance with processing and inspection standards other than those specified (see B.3.6.1).
- h. When alternate ultrasonic soundness inspection requirements apply (see B.3.6.2, B.3.7, B.3.7.1, and B.4.6.5.1).
- i. If plates over ½ inch thick are not to be ultrasonically inspected and ultrasonically measured for decimal thickness (see B.3.7).
- j. When Type I plates are to be ultrasonically inspected for soundness (see B.3.7).
- k. The applicable fabrication document (see B.3.8).
- l. When ordered to thickness, weight, or gauge (see B.3.9.1).
- m. When tighter tolerances are desired (see B.3.9.2).
- n. When descaling and coating are not required (see B.3.10).
- o. Type of coating required (see B.3.10 and Appendix K).
- p. When explosion bulge type testing is required (see B.3.12).
- q. When first article specimens shall be located in areas other than shown on [Figure A-1](#) and [Figure A-2](#) (see B.4.3).
- r. When HY-80 and HY-100 are to be tested together (see B.4.3).
- s. When HY-100 has passed first article testing, whether explosion testing of HY-80 bulge data is required (see B.6.4.1).

B.6.3 Thin Plates. Plates under 7.65 lb/ft² [37.4 kg/m²] should be ordered under this specification only when they are for structural purposes where strength and gauge are important.

B.6.4 First Article. See 6.3.

B.6.4.1 First Article Approval. When Grade HY-100 plate material has qualified to first article test requirements, Grade HY-80 may be reviewed for first article approval by submitting the required first article inspection data exclusive of explosion tests unless specifically required by the contract or acquisition document (see B.6.2).

B.6.4.2 Ingot or Continuous Casting Process. The rolling of the plate or slabs, the laying out of test specimens, and the testing should be witnessed by ABS or DCMA representative.

B.6.5 Receipt Inspection. The plates should be subject to receipt inspection (including chemical composition and mechanical property tests) by consignee to verify conformance to all requirements of the specification. Plates not conforming to the requirements of the specification at any location in the plate may be rejected by the consignee. The plate

T9074-BD-GIB-010/0300 Rev 2

manufacturer may verify the results of the consignee's receipt inspection. It is the responsibility of the consignee to determine acceptability of the plates for the intended application.

B.6.6 Dynamic Tear. Dynamic tear test results at 0 °F should be regarded for informational purposes only.

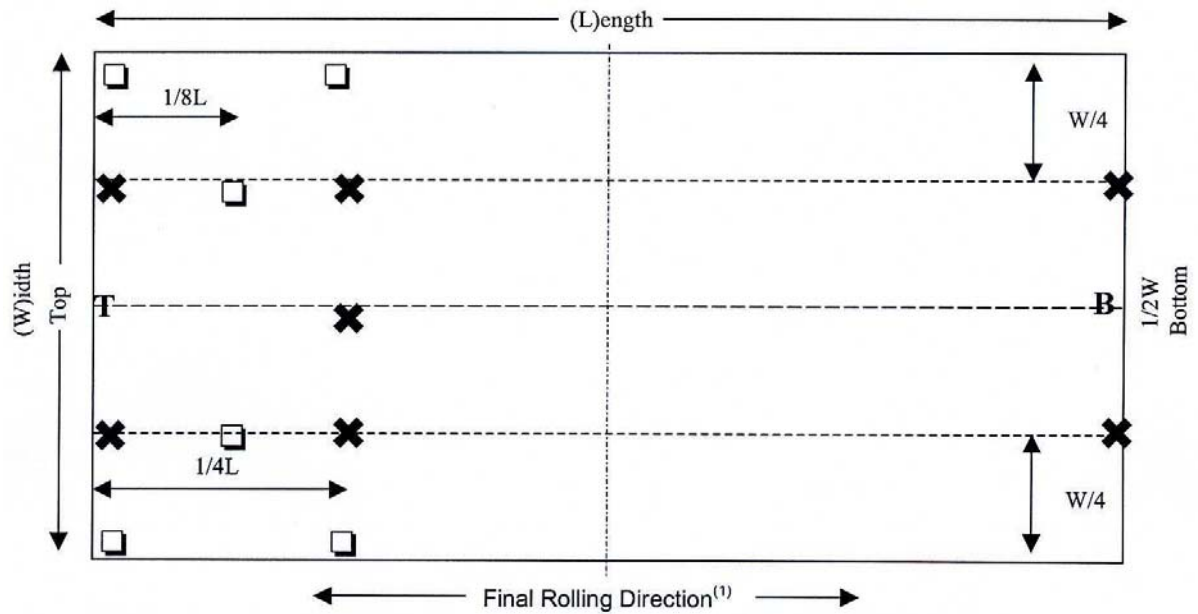

Test	Location Symbol	Comments
Tensile (longitudinal) ⁽²⁾	✕	Surface and mid-thickness depth (1 test at room temperature at each location).
Tensile (transverse) ⁽³⁾	✕	Surface and mid-thickness depth (1 test at room temperature at each location).
Chemical Composition	✕	Full chemistry from all broken transverse tensiles.
Chemical Composition ⁽⁴⁾	□	Full chemistry from surface and mid-thickness location.
CVN (transverse) ⁽²⁾	✕	See B.4.4.2.4 for specimen depth (3 tests at -120 °F and 3 tests at 0 °F, at each location).
5/8 Inch DT (transverse) ⁽²⁾	✕	See B.4.4.2.4 for specimen depth (2 tests at -40 °F and 2 tests at 0 °F, at each location).
CVN Transition Curve ⁽⁵⁾	▲	See B.4.4.2.4 for specimen depth (3 tests at each of the following temperatures: -120 °F, -90 °F, -40 °F, 0 °F, and 30 °F).
5/8 Inch DT Transition Curve ⁽⁵⁾	○	See B.4.4.2.4 for specimen depth (2 tests at each of the following temperatures: -120 °F, -90 °F, -40 °F, 0 °F, and 30 °F).
Multiple Tests	T	Conduct the following tests at this location: ✕, □, ○, ▲
Multiple Tests	B	Conduct the following tests at this location: ✕, □

NOTES:

- (1) The final rolling direction is the direction of rolling in which the greatest reduction ratio is achieved. For example, if 25 percent reduction of the initial slab or ingot thickness is achieved by rolling in direction A, and 75 percent reduction of the initial thickness is achieved by rolling in direction B, then direction B is the final rolling direction.
- (2) CVN, DT, and longitudinal tensile, from the top and bottom locations, shall be removed from material up to 12 inches from the as-cut edge of the plate, but not closer than 4 inches from the as-heat-treated edge of the plate.
- (3) Transverse tensile specimens from top and bottom locations shall be removed from the as-cut edge of the plate, but not closer than 4 inches from the as-heat-treated edge of the plate.
- (4) Specimens shall be removed from as-cut edge(s) of the plate, but not closer than 4 inches from as-heat-treated edge of the plate.
- (5) Specimens shall be removed from material up to 12 inches, but not closer than 4 inches from the as-heat-treated edge of the plate.

Figure B-1. First Article Inspection Testing (Plate <3 Inches Thick).

T9074-BD-GIB-010/0300 Rev 2

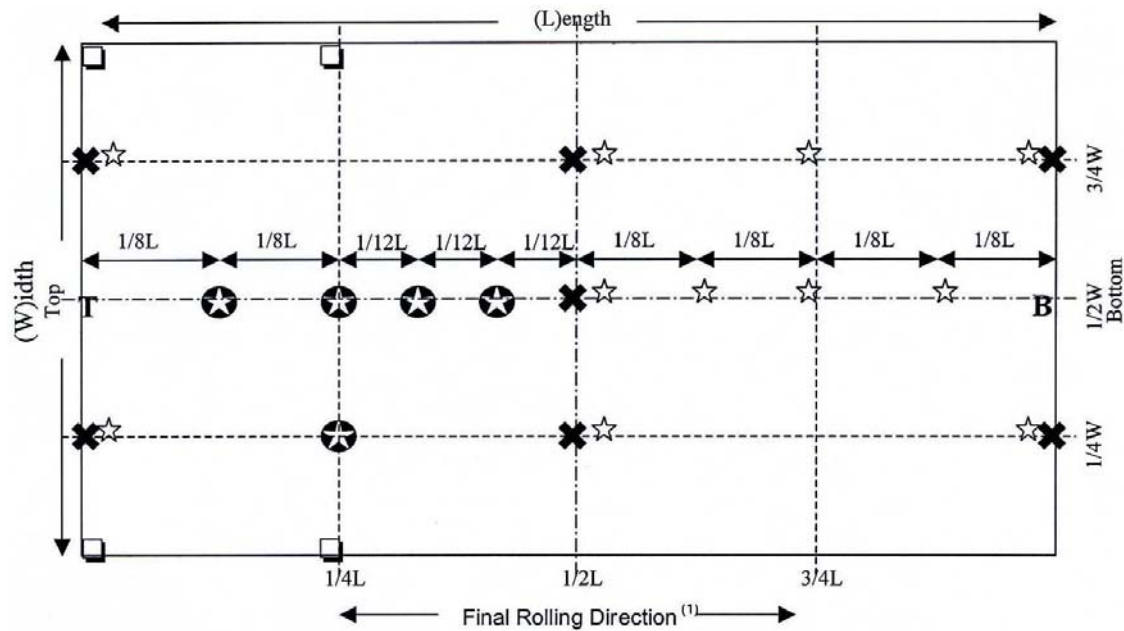

Test	Location Symbol	Comments
Tensile (longitudinal) ⁽²⁾	✕	Surface and mid-thickness depth (1 test at room temperature at each location).
Tensile (transverse) ⁽³⁾	✕	Surface and mid-thickness depth (1 test at room temperature at each location).
Tensile (through thickness) ⁽²⁾	☆	Mid-length of specimen at mid-thickness depth (2 tests at each location).
Chemical Composition	✕	Full chemistry from all broken transverse tensiles.
Chemical Composition and Through Thickness Tensile	⊗	Full chemistry from gage length of one broken through thickness tensile.
Chemical Composition ⁽⁴⁾	□	Full chemistry from surface and mid-thickness location.
CVN (transverse) ⁽²⁾	✕	See B.4.4.2.4 for specimen depth (3 tests at -120 °F and 3 tests at 0 °F, at each location).
5/8 Inch DT (transverse) ⁽²⁾	✕	See B.4.4.2.4 for specimen depth (2 tests at -40 °F and 2 tests at 0 °F, at each location).
CVN Transition Curve ⁽⁵⁾	▲	See B.4.4.2.4 for specimen depth (3 tests at each of the following temperatures: -120 °F, -90 °F, -40 °F, 0 °F, and 30 °F).
5/8 Inch DT Transition Curve ⁽⁵⁾	○	See B.4.4.2.4 for specimen depth (2 tests at each of the following temperatures: -120 °F, -90 °F, -40 °F, 0 °F, and 30 °F).
Multiple Tests	T	Conduct the following tests at this location: ✕, ☆, □, ▲, ○
Multiple Tests	B	Conduct the following tests at this location: ✕, ☆, □,

NOTES:

- (1) The final rolling direction is the direction of rolling in which the greatest reduction ratio is achieved. For example, if 25 percent reduction of the initial slab or ingot thickness is achieved by rolling in direction A, and 75 percent reduction of the initial thickness is achieved by rolling in direction B, then direction B is the final rolling direction.
- (2) Longitudinal tensile, through thickness tensile, 5/8 inch DT and CVN specimens, from the top and bottom locations, shall be removed from material up to 12 inches from the as-cut edge of the plate, but not closer than 4 inches from the as-heat-treated edge of the plate.
- (3) Transverse tensile specimens from top and bottom locations shall be removed from the as-cut edge of the plate, but not closer than 4 inches from the as-heat-treated edge of the plate.
- (4) Specimens shall be removed from as-cut edge(s) of the plate, but not closer than 4 inches from as-heat-treated edge of the plate.
- (5) Specimens shall be removed from material up to 12 inches, but not closer than 4 inches from the as-heat-treated edge of the plate.

Figure B-2. First Article Inspection Testing (Plate ≥3 Inches Thick).

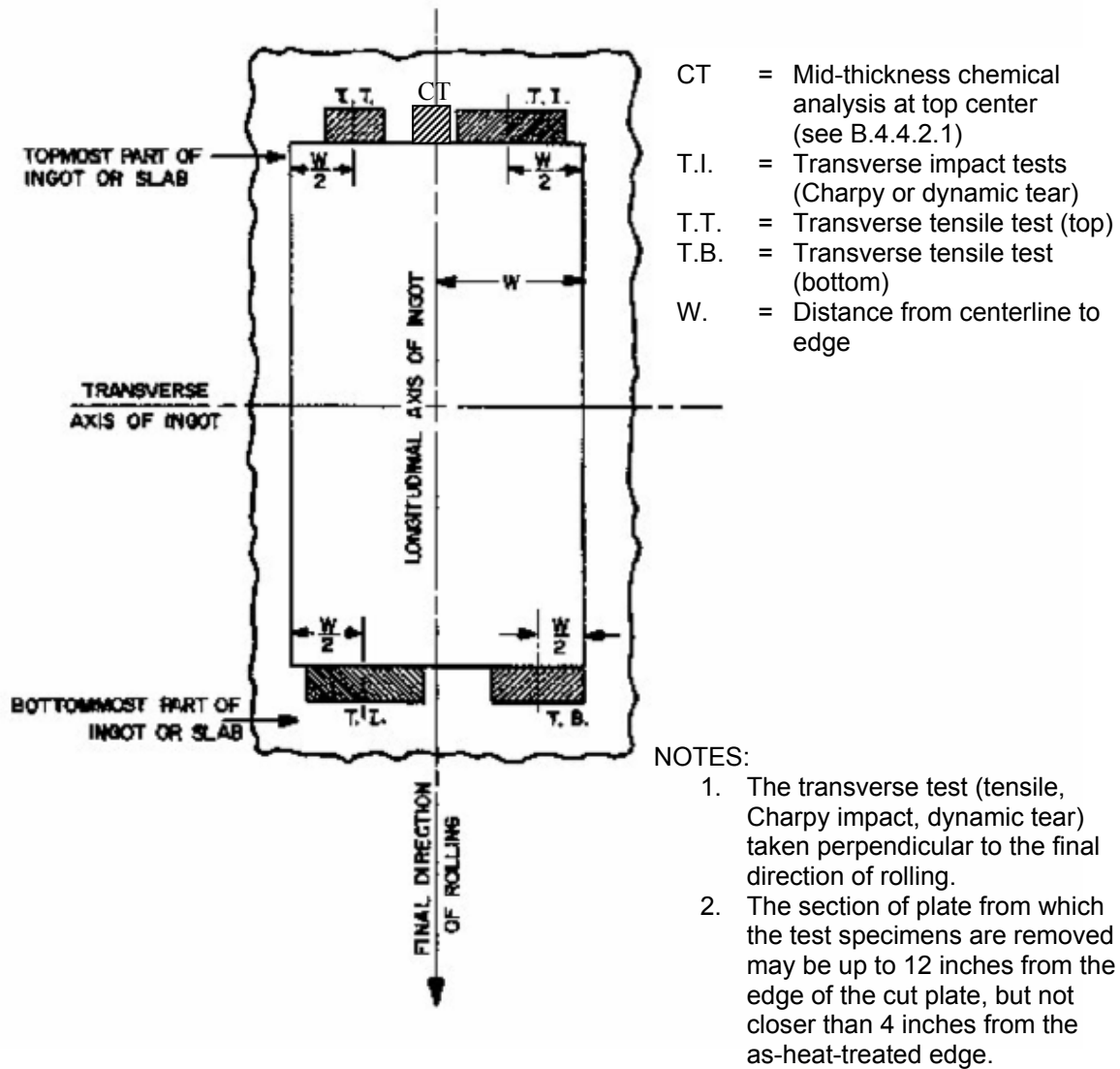

Figure B-3. Method of Locating Test Specimens for Conformance Inspection for Plates as Rolled Directly from Ingots or Slabs with the Final Direction of Rolling Parallel to the Longitudinal Axis of the Ingot.

T9074-BD-GIB-010/0300 Rev 2

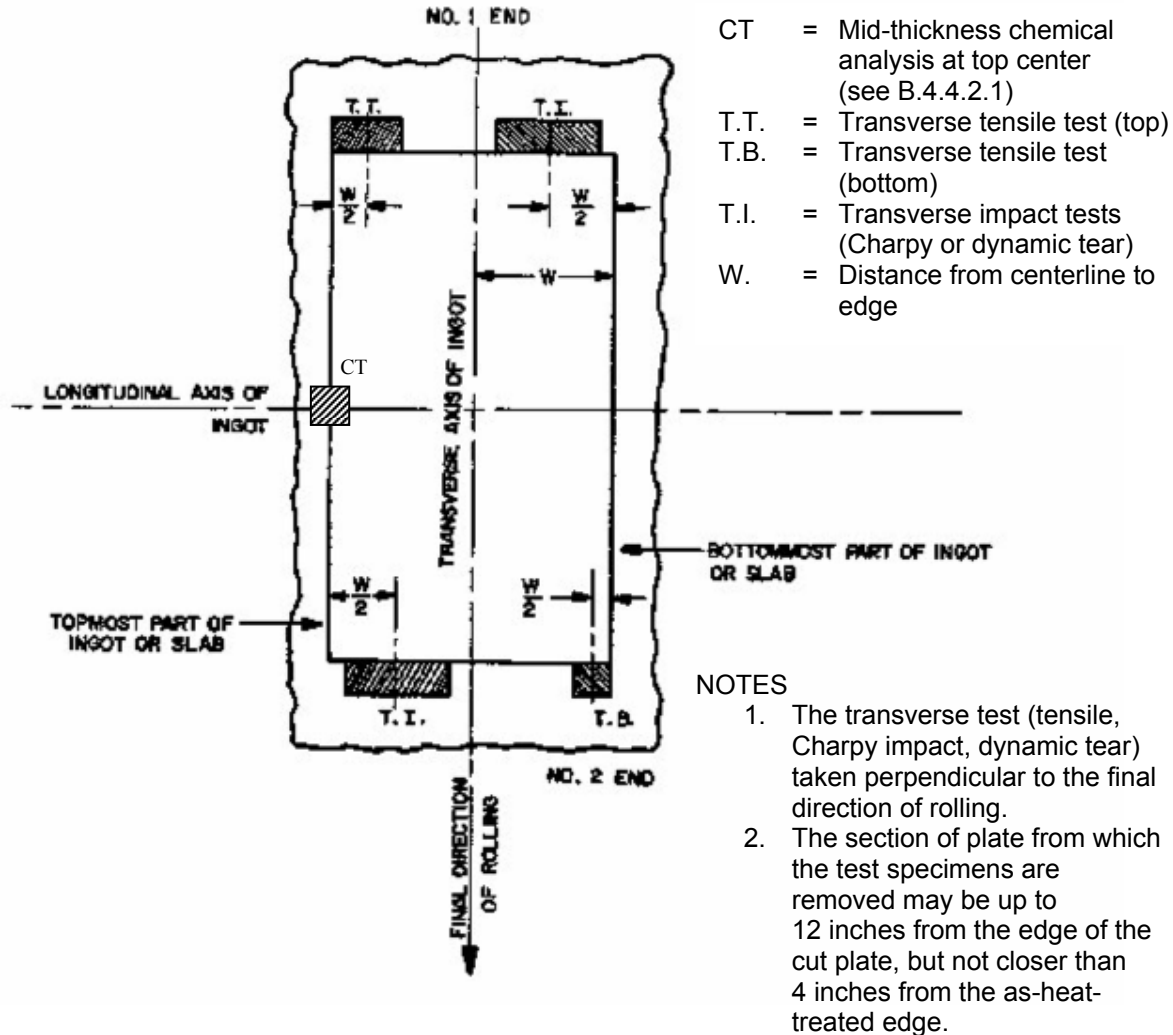

Figure B-4. Method of Locating Test Specimens for Conformance Inspection for Plates as Rolled Directly from Ingots or Slabs with the Final Direction of Rolling Parallel to the Transverse Axis of the Ingot.

APPENDIX C (24512)

STEEL FORGINGS, ALLOY, STRUCTURAL, HIGH YIELD STRENGTH (HY-130)

C.1 SCOPE.

C.1.1 Scope. This appendix covers HY-130 steel forgings intended primarily for use in combatant submarine hulls.

C.2 APPLICABLE DOCUMENTS.

See Chapter 2.

C.3 REQUIREMENTS.

C.3.1 Forging Process. The original cross-sectional area of the ingot shall be at least three times the cross-sectional area of the main body of the forging. Palms, flanges, and other enlargements on forgings need not be reduced to the ratio of 3 to 1, but shall be reduced in a ratio of not less than 1.7 to 1. If bored ingots are used, the wall of the ingot shall be reduced to at least ½ of its original thickness. Where an upsetting operation is employed, or the forging expanded on a mandrel, the metal shall be worked to an extent not less than that indicated above, but in no fixed ratio between the cross-sectional area of the ingot and that of the forging.

C.3.1.1 Bored Forgings. Where the forgings are to be bored, the centerline of the ingot shall be either in a bored hole or in discarded material.

C.3.2 Chemical Composition. The chemical analysis, heat and product, shall be as specified in [Table C-1](#). Product analysis shall conform to [Table C-1](#) as modified by the product analysis tolerances specified in ASTM A788, unless otherwise specified (see C.6.2).

Table C-1. Chemical Composition (Weight Percent). ^{1/}

Element	Weight percent
Carbon	0.12
Manganese	0.60 – 0.90
Phosphorus	0.010
Sulfur	0.010
Silicon	0.20 – 0.35
Nickel	4.75 – 5.25
Chromium	0.40 – 0.70
Molybdenum	0.30 – 0.65
Vanadium	0.05 – 0.10
Titanium	0.02
Copper	0.25
Arsenic ^{2/}	0.025
Antimony ^{2/}	0.025
Tin ^{2/}	0.03
NOTES:	
^{1/} Single values are maximum percentages.	
^{2/} Elements shall not be added intentionally.	

T9074-BD-GIB-010/0300 Rev 2

C.3.3 Tensile Properties. The material shall meet the tensile property requirements as specified in [Table C-2](#) after heat treating has been performed. Properties shall be determined in both the longitudinal and transverse directions.

Table C-2. Tensile Properties – Longitudinal and Transverse.

Property	Required Value
Yield strength, 0.2 percent offset, (ksi) [MPa]	130 – 145 [896 – 1000]
Ultimate tensile strength, ksi	<u>1</u> /
Elongation in 2-inch (minimum percent)	15
Reduction of area (minimum percent)	50
NOTES:	
<u>1</u> / Not required; to be recorded for information only.	

C.3.4 Impact Requirements. Unless otherwise specified (see C.6.2), the forgings shall exhibit a minimum average Charpy V-notch (CVN) impact energy of 55 ft-lbs at both 0 °F and +70 °F. The average impact energy at +70 °F shall not exceed the average at 0 °F by more than 15 ft-lbs. No individual CVN value shall be lower than 40 ft-lbs.

C.3.4.1 Alternative Impact Requirements. In addition to CVN impact testing, transverse dynamic tear (DT) testing may be required when specified (see C.6.2). A minimum average $\frac{5}{8}$ -inch DT energy of 500 ft-lbs at 0 °F is required. No individual DT value shall be more than 25 ft-lbs below the minimum average.

C.3.5 Heat Treatment. The Contractor shall determine the detailed procedure that will produce forgings that will meet the mechanical requirements specified herein, with the following restrictions:

- a. The forgings shall be quenched and tempered. The producer shall determine the detailed procedure for heat treating the forgings to meet the mechanical property requirements, with the exception that the final austenitizing temperature shall be specified by the producer and shall not exceed 1650 °F, and the tempering temperature shall be not less than 1000 °F.
- b. Forgings shall be water quenched after tempering. After austenitizing and tempering, all forgings, including the test block(s), that constitute the furnace load shall be removed from the furnace and rapidly cooled by water quenching at the same time (i.e., the same quench load). The use of more than one quench load for tempering and stress relief heat treatment of a single furnace load of forgings is prohibited. Test blocks shall be quenched at the same time (i.e., in the same quench load) as the forgings(s) that they represent. All forgings shall be arranged such that, as far as possible, they and the test block receive equal and uniform exposure to the quench media.
- c. Unless otherwise specified (see C.6.2), the tempering and stress relief heat-treat cycles shall have the following contact thermocouples attached to the forging(s) and the test blocks during the cycles: one contact thermocouple shall be placed on thickest and thinnest sections of the forgings in the furnace load, and on the forging or test block surface closest to a furnace burner. In addition, one contact thermocouple shall be placed on each test block representing the furnace load. Upon reaching the target tempering and stress relief heat treatment temperature, the temperatures of all forging thermocouples shall fall within ± 25 °F degrees of the test block temperature.
- d. For all heat treatment operations, forgings shall be positioned and supported in such a manner to prevent shifting or falling from their initial set positions during the heat treatment process. In addition, during tempering, forgings shall be positioned in the furnace so that in a direct-fired furnace, burner flames and hot gases from these flames cannot impinge upon forging surfaces and result in heating the forgings above the maximum allowable tempering temperature. As a minimum, the forgings shall be supported in the furnace by a grating/floor structure or similar structure that ensures that the forgings cannot fall or shift outside of the furnace working zone and be exposed to burner flames or hot gases. Attention shall be given to ensure that the structure supporting the grating/floor in the furnace, such as pylons, sawhorses, and racks, will not deflect flames and hot gases onto forging surfaces and that these supports are in a permanent/semi-permanent position.
- e. In addition to the requirements of 3.5 for batch-type furnaces, the heat treatment record shall also include photographs and/or sketches providing sufficient accuracy to recreate positions and orientations of the forgings in the furnace at future dates. The photographs and/or sketches in the heat treatment record shall be of the furnace car forging-load immediately prior to entering and immediately after leaving the furnace for the tempering cycle(s). The photographs and/or sketches in the heat treatment record shall include placement of forgings, forging support structure (i.e., pylons, saw horses, racks, etc.) on the furnace car, placement of the burners in the furnace, and the distances and orientations of the forging and support structure with respect to the burners. The verification of

inspection record shall validate the forging was loaded in accordance with the sketches and/or photographs in the heat treatment record. The verification of inspection record shall also validate the sketch(es) and/or photograph(s) are consistent with all support structure and forging positions during the tempering heat treatment.

- f. The quench tank facility used to accomplish the austenitizing heat treatment shall be of sufficient capacity and design to provide multi-directional (from at least three directions or other effective design based on results of first article testing) water flow for effective quenching of the largest forgings to be heat treated. The effectiveness of the quench tank facility in terms of capacity and water flow shall be demonstrated during first article testing where both the largest size (i.e., thickness and complexity) forging and the accompanying test blocks are demonstrated to meet the minimum mechanical property requirements. The maximum quench tank water temperature at the initiation of the quenching operation shall not exceed 80 °F.

C.3.5.1 Reheat Treatment. The manufacturer shall be permitted to reheat treat forgings that fail to meet the tensile or impact requirements of this specification. All required tests originally performed on the failed forgings except chemical analysis and ultrasonic inspection (if previously performed) shall be repeated when the material is re-inspected.

C.3.6 Stress Relief. Forgings shall not be stress relieved subsequent to final heat treatment.

C.3.7 Cleaning. Scale due to forging at elevated temperatures shall be removed to sound base metal so that visual, dimensional, and non-destructive evaluation can be satisfactorily accomplished.

C.3.8 Dimensions and Tolerances. Forgings shall meet the dimensions and tolerances specified on the applicable drawings (see C.6.2). The responsibility for furnishing forgings that can be machined to the finished dimensions within the tolerances given and without further straightening shall rest with the Contractor. Layout points, when required, shall be shown as such on the applicable drawings and shall be suitably incorporated in the forgings. Forgings outside of weight or dimensional tolerances shall be subject to rejection.

C.3.9 Soundness. Each forging shall be free of harmful defects as determined by visual examination, magnetic particle testing, and ultrasonic inspection.

C.3.9.1 Magnetic Particle Inspection. Unless otherwise specified (see C.6.2), 100 percent of each forging's surface shall be magnetic particle inspected in accordance with L.7.3.3. The forging shall be in the finished condition ready for shipment as specified.

C.3.9.2 Ultrasonic Inspection. Each forging shall be ultrasonically tested for internal soundness. Any discontinuity whose reflection exceeds the calibration standard set forth in the table of T9074-AS-GIB-010/271 titled "Calibration hole size for longitudinal test" shall be cause for rejection of the forging.

C.3.9.3 Macroscopic Examination. After final heat treatment, forgings shall be demonstrated to be free from cast dendritic structure based on macroscopic examination at 5X magnification per ASTM E381.

C.3.10 Defect Repair. Defects may be removed by chipping, grinding, or other mechanical means, provided the involved area is well faired into the surrounding area and the design dimensions are not violated. Defects shall not be removed by arc cutting or oxygen cutting processes. Weld repair is prohibited unless specifically approved on a case basis by the Command or Agency concerned. The contour of the excavated area shall have a minimum radius of $\frac{3}{8}$ inch (10 mm). Repaired areas shall be magnetic particle inspected and meet the criteria of C.3.9.1.

C.3.11 Marking. Each forging shall be permanently marked with the manufacturer's name or trademark, the designation HY-130, and a serial number which will positively identify the forging's part number, melt, and heat treated lot. Markings shall be placed in a location such that they are not machined off in finishing and in an area that is stressed least in service.

C.3.12 Explosion Testing. Explosion testing is required as part of first article testing and is not required for conformance testing. Two explosion crack starter tests are required for first article testing. Both specimens shall conform to the crack starter configuration requirements on [Figure L-8](#) and meet the explosion crack starter requirements in Appendix L. When explosion bulge type testing is specified (see C.6.2), testing shall be in accordance with Appendix L. During explosion bulge testing following the second shot, in the event that a 7 percent reduction in plate thickness is obtained on both sides of the weld, or a 7½ percent reduction in plate thickness is obtained on one side of the weld, the performance is considered satisfactory and the third shot shall not be made provided the following conditions are met:

- a. No piece shall be thrown out of the material being tested.
- b. Through thickness cracks are acceptable.
- c. No cracks shall extend into the hold down area (see Appendix L).

T9074-BD-GIB-010/0300 Rev 2

C.3.13 Forging Sketches. A forging sketch shall be prepared that shows the maximum reduction ratio that is to be achieved in each portion of the forging. Location of specimens for tensile and impact properties as shown on [Figure C-1](#), [Figure C-2](#), and [Figure C-3](#) are to be considered when preparing the forging sketch for symmetrical forgings.

C.4 VERIFICATION.

C.4.1 Responsibility for Inspection. See 4.1.

C.4.2 Classification of Inspections. The inspection requirements specified herein are classified as follows:

- a. First article inspection (see C.4.3).
- b. Conformance inspection (see C.4.4).

C.4.3 First Article Inspection. First article inspection shall consist of testing the samples specified in [Table C-3](#) (see 4.3, 6.3, and Appendix L). First article inspection is required for forging sources melting their own forging stock or using stock from an unapproved source. Approval of a reforger using an approved source may be extended to all other approved sources of stock without further testing other than conformance.

Table C-3. First Article and Conformance Requirements.

Examination and Tests	Requirement	Test Method	First Article	Conformance
Chemical analysis	C.3.2	4.5.1 and C.4.5.1	X	X
Tensile properties	C.3.3	4.5.2	X	X
Explosion	3.11	4.5.5	X	
Impact Properties				
Charpy V-notch	C.3.4	4.5.3	X	X
Dynamic tear	C.3.4.1	4.5.4	X	X <u>1/</u>
Examination				
Surface quality	C.3.9.1	C.4.4	X	X
Dimensional	C.3.8	4.4.3 and C.6.2.f	X	X
Soundness	C.3.9.2	C.4.4.2.6 and C.4.4.2.7	X	X
Macroscopic	C.3.9.3	C.4.4.2.8	X	X
NOTES:				
<u>1/</u> When specified as alternative to Charpy V-notch tests.				

C.4.3.1 First Article Samples. First article samples shall consist of material from one heat sufficient to obtain measurements of the mechanical properties of the material and its weldment. In addition, weldments shall be subjected to the explosion test as specified in Appendix L. The test shall be conducted under Government direction to evaluate weldment performance in shock applications.

C.4.3.1.1 Forgings. First article samples shall be forgings representative of the largest size (i.e., section thickness) to be forged at the facility and from one lot (see C.4.4.1). A minimum of two forgings of largest size and sufficient complexity to demonstrate the capability to provide homogeneous forgings with uniform chemistry and mechanical properties throughout the forging section shall be produced for first article inspection.

C.4.3.1.2 Test Prolongations. Prolongations sufficient to meet the testing requirements of this specification shall be provided. Prolongations shall be part of the forgings until after heat treatment.

C.4.3.1.2.1 Prolongation Size. The size of the prolongation shall be equivalent to the largest cross-section of the forging.

C.4.3.1.3 Explosion Test Specimens. Twelve unwelded plate forgings 2 by 16 by 55 inches (51 by 406 by 1397 mm) shall be provided for explosion testing as specified in C.3.12 and 4.5.5.

C.4.3.1.4 Test Specimen Location. Test specimens for first article testing shall be taken from the prolongations and from the prototype forgings. Samples shall be taken from the prototype forgings at the center and from opposite extremes (the locations between which the longest straight line can be drawn). Samples from the prolongations shall be taken as specified in C.4.4.2.2.1. All test specimens shall be taken at a depth of T/2 inches from the heat treated surface, for T up to 6 inches. T

is defined as the as-quenched thickness (minimum dimension) of the heaviest cross-section of the forging. Specimen locations and requirements for forgings with T greater than 6 inches shall be as specified by the purchaser (see C.6.2).

C.4.3.1.4.1 Charpy V-Notch Test. A set of six CVN impact specimens (three longitudinal and three transverse) shall be tested from each of the locations specified in C.4.3.1.4 at each of the following temperatures, 0 °F and +70 °F. Average CVN energy values at +70 °F shall not exceed average energy values at 0 °F (for the same specimen orientation) by more than 15 ft-lbs. No individual Charpy V-notch energy value shall be lower than 40 ft-lbs.

C.4.3.1.4.2 Chemical Analysis. Chemical analysis shall be determined at each of the locations specified in C.4.3.1.4 and from a suitably prepared heat analysis sample.

C.4.3.1.4.3 Tensile Test. A tensile test specimen shall be taken at the locations specified in C.4.3.1.4.

C.4.3.1.4.4 Dynamic Tear Test. A set of two transverse dynamic tear test specimens shall be taken from both the center of the prototype forgings and the prolongations. These specimens shall be tested at -40 °F.

C.4.3.1.4.5 Charpy Impact Transition Curves. CVN transition curves (longitudinal and transverse) with a minimum of five temperatures from -120 °F to room temperature (+70 °F) shall be obtained from the prototype forgings and the prolongations at the locations specified in C.4.3.1.4. A minimum of five specimens for each temperature is required, and all individual values shall be reported.

C.4.3.1.4.6 Macroetch Specimen. A specimen shall be removed from each prolongation and macroetched with an appropriate etchant to show that a worked microstructure exists through the thickness of the prolongation and that there is no evidence of as-cast dendritic microstructure.

C.4.3.2 First Article Inspection Report. See 3.1.

C.4.4 Conformance Inspection. Conformance inspection (i.e., inspections of production lots) shall consist of the examinations and tests specified in [Table C-3](#).

C.4.4.1 Lot Definitions.

C.4.4.1.1 Lot for Tension and Impact Tests.

- a. Forgings with an as-heat-treated weight of less than 250 pounds (113 kg): All forgings of one design, produced from the same heat or melt, and heat treated in the same furnace charges and quenched at the same time shall constitute a lot.
- b. Each forging weighing more than 250 pounds shall be considered a lot.

C.4.4.1.2 Lot for Examination and Inspections. For purposes of visual and dimensional inspection and for nondestructive inspection, each forging shall constitute a lot.

C.4.4.2 Sampling for Conformance Inspection.

C.4.4.2.1 Sampling for Chemical or Spectrographic Analysis. The test sample shall be taken during the pouring of the heat at a time that best represents the composition of the cast. In case the heat analysis samples are lost or inadequate, or when it is evident that the sample does not truly represent the heat, representative samples may be taken from the product. The analysis shall meet the specified limits for heat analysis.

C.4.4.2.2 Sampling for Tensile and Impact Tests. Sampling for tensile and impact properties shall be as follows:

- a. From each lot as defined by C.4.4.1.1.a, 25 percent of the forgings shall be tested for tensile and impact properties.
- b. From each lot as defined by C.4.4.1.1.b, each forging shall be tested for tensile and impact properties.

C.4.4.2.2.1 Location, Orientation, and Number of Specimens. Unless otherwise specified (see C.6.2), the location of the test specimens shall be in accordance with the forging sketches (see C.3.13) that shall reflect the locations on [Figure C-1](#), [Figure C-2](#), and [Figure C-3](#), as applicable. One longitudinal and one transverse tensile, three transverse CVN impact and, if specified in C.6.2, two transverse DT specimens for each test temperature shall be removed from the forging and tested.

C.4.4.2.2.2 Location of Tensile and Impact Specimens. Integral prolongations of full section thickness shall be provided whenever feasible. If integral prolongations are not feasible, then a production forging or a forged block of representative section size, made from the same heat and subjected to the same degree of hot working as the forging it represents, may be used for test material. When prolongations are used but it is impractical to provide enough material to meet the required distance between test material and quenched surfaces, then metal buffers may be used to meet the distance requirement for quenching. The buffer material may be any weldable low-carbon or low-alloy steel and shall be joined to the forging with a partial penetration weld that completely seals the buffered surface.

T9074-BD-GIB-010/0300 Rev 2

C.4.4.2.3 Multiple Forgings. When forgings are made and heat treated in multiples, such as two or more individual pieces machined from a single heat treated forging, specimens representing the composite forging shall be required. The composite forgings' weight and size shall govern the lot definition and scheme of testing.

C.4.4.2.4 Orientation of Tensile and Impact Specimens. Unless otherwise shown on the forging sketches (see C.3.13), the orientation of tensile and impact specimens shall be as specified in E.4.4.3.2.

C.4.4.2.5 Marking of Test Specimens. The test specimens shall be marked to ensure positive identification of the lot being tested.

C.4.4.2.6 Sampling for Forging Soundness (Internal). Unless otherwise specified (see C.6.2), each forging shall be ultrasonically tested (see C.4.5.2) at a point in processing which will produce a meaningful test in determining conformance to the soundness requirements specified in C.3.9. Scanning shall be such that 100 percent of the forging's cross-section is probed from three principal directions; for example, from the end, side, and top for rectangular forgings; from the end and 180 degrees of the circumference of solid rounds; and from the end and 360 degrees of the circumference of bored rounds. For long or rectangular parts, inspection shall be at least equal to part thickness calibration.

C.4.4.2.7 Sampling for Forging Soundness (External). Each forging shall be subject to magnetic particle inspection. Each forging shall be in the finished condition ready for shipment as specified (see C.4.5.3).

C.4.4.2.8 Macroscopic Examination. After final heat treatment, a full thickness cross-section shall be removed from each prolongation. Each cross-section shall be subjected to macroscopic examination and shall meet the requirements in C.3.9.3.

C.4.5 Test Procedures. See [Table C-3](#) and 4.5.

C.4.5.1 Chemical or Spectrographic Analysis. If any analysis fails to conform to C.3.2, the lot represented by that analysis shall be rejected. When both a heat and product analysis are determined, the product analysis shall be used to determine acceptance or rejection.

C.4.5.2 Ultrasonic Test. Ultrasonic testing shall be performed in accordance with T9074-AS-GIB-010/271.

C.4.5.3 Magnetic Particle Inspection. Unless otherwise specified (see C.6.2), 100 percent of each forging's surface shall be magnetic particle tested in the final heat treated condition in accordance with T9074-AS-GIB-010/271. Bored surfaces shall be examined for three times the bore diameter from each end only. When magnetic particle testing is injurious to a machined surface, dye penetrant testing in accordance with T9074-AS-GIB-010/271 is a satisfactory substitute.

C.5 PACKAGING.

See Chapter 5.

C.6 NOTES.

C.6.1 Intended Use. The HY-130 steel forgings covered by this specification are intended for combatant submarine hull use. This steel may be used in surface ship construction or other critical structural applications where a weldable, notch-tough, high-strength material is required. This steel can also be used to fabricate welded pressure vessels and other machinery items of critical use where an as-welded, notch-tough, high yield strength steel is required. The use of HY-130 steel in fabricated structure or equipment entails much more than a material specification and caution is advised in the areas of welding, fabrication, and nondestructive testing.

C.6.2 Acquisition Requirements. Acquisition documents must specify the following:

- a. Title, number, and date of this specification.
- b. If chemical product analysis tolerances are to be different than those specified in ASTM A788 (see C.3.2).
- c. If forgings are to have minimum average CVN impact energy other than 55 ft-lbs at 0 °F and 70 °F (see C.3.4).
- d. If $\frac{5}{8}$ -inch DT testing is required (see C.3.4.1).
- e. If thermocouples are required in alternate locations (see C.3.5.c).
- f. Dimensions and tolerances required (see C.3.8).
- g. When magnetic particle inspection is other than 100 percent (see C.3.9.1).
- h. When explosion bulge type testing is required (see C.3.12).
- i. Specimen location and requirements for forgings with T greater than 6 inches (C.4.3.1.4).

- j. If specimen locations other than shown on forging sketches are required (see C.4.4.2.2.1).
- k. If the ultrasonic testing will occur at a time other than at the latest point in processing possible (see C.4.4.2.6).
- l. If less than 100 percent of each forging's surface shall be tested (see C.4.5.3).

T9074-BD-GIB-010/0300 Rev 2

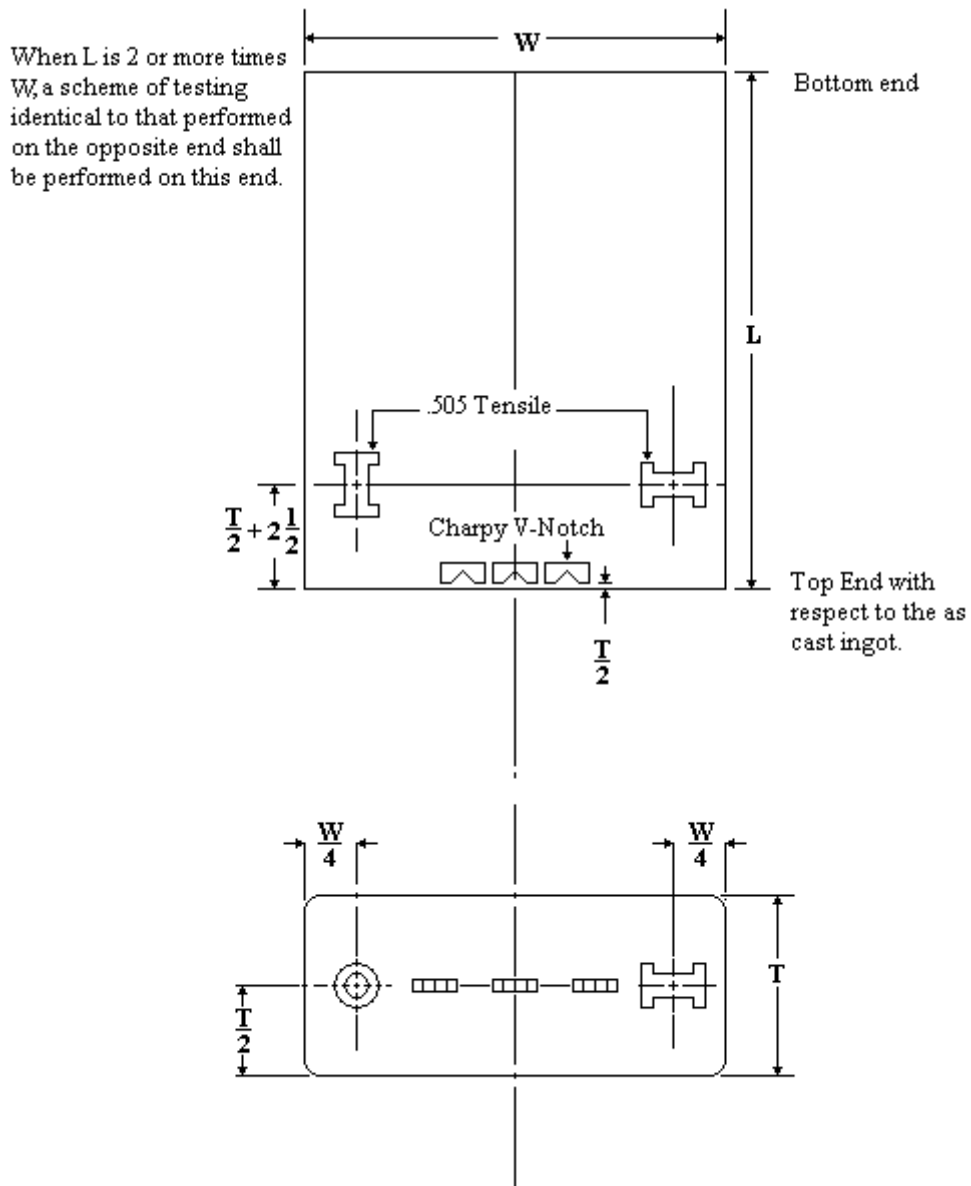

Figure C-1. Typical Schematic Diagram of Test Specimen Location for 6-Inch Thick Forgings, “Rectangular Like” in Cross-Section. (See C.4.4.2.2 for details on test specimen location.)

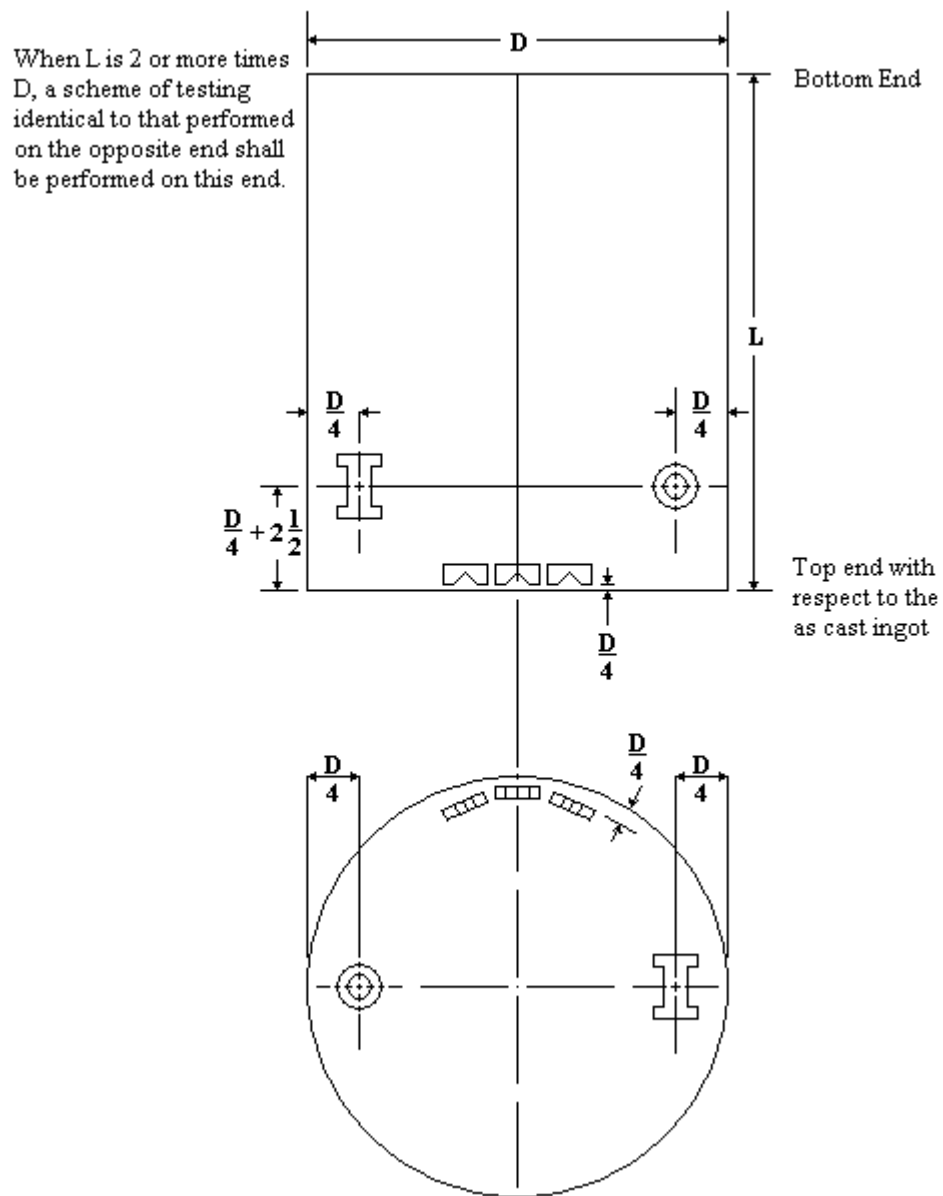

Figure C-2. Typical Schematic Diagram of Test Specimen Location for 12-Inch Thick Forgings of Solid Circular Cross-Section. (See C.4.4.2.2 for details on test specimen location.)

T9074-BD-GIB-010/0300 Rev 2

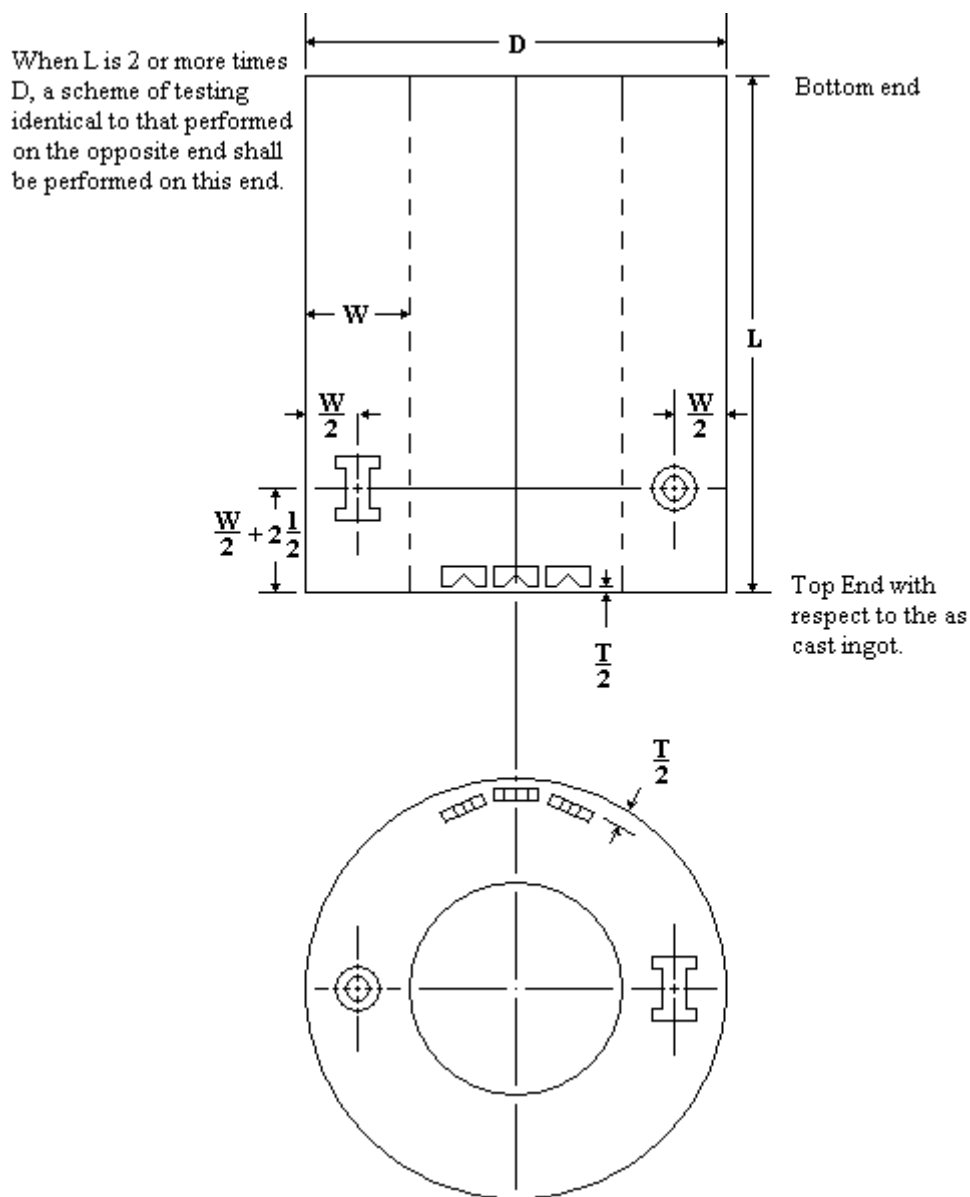

Figure C-3. Typical Schematic Diagram of Test Specimen Location for 6-Inch Thick Forgings of Hollow Circular Cross-Section. (See C.4.4.2.2 for details on test specimen location.)

APPENDIX D (23008) STEEL CASTINGS, ALLOY, HIGH YIELD STRENGTH (HY-80 AND HY-100)

D.1 SCOPE.

D.1.1 Scope. This appendix covers Grade HY-80 and Grade HY-100 steel castings intended for critical structural applications where a weldable, notch-tough, high-strength material is required.

D.1.2 Classification. Steel castings shall be of the following grades, as specified (see D.6.2).

Grade HY-80 - 80,000 lb/in² (80 ksi) [552 MPa] tensile yield strength, minimum.

Grade HY-100 - 100,000 lb/in² (100 ksi) [690 MPa] tensile yield strength, minimum.

D.2 APPLICABLE DOCUMENTS.

See Chapter 2.

D.3 REQUIREMENTS.

D.3.1 Material. Castings shall be produced from electric furnace steel, which will be capable of producing the quality requirements of the first article castings, and the requirements of all procurement documents thereafter. Additional refining processes (AOD, VOD) may be specified (see D.6.2) to produce steel of acceptable quality.

D.3.2 Chemical Composition. The chemical composition of the heat analysis shall be in accordance with [Table D-1](#). Product analysis shall conform to [Table D-1](#) as modified by the product analysis tolerances specified in ASTM A703.

D.3.2.1 Chaplets and Chills. When chaplets are used, they shall be composed of material as specified in [Table D-1](#) or removed and weld repaired. Internal chills shall not be used without NAVSEA approval.

D.3.3 Thickness Definition.

- a. The casting thickness (CT) shall be defined as the diameter of the greatest inscribed sphere in the as-cast part envelope to the exclusion of rigging and risers.
- b. The heat treated thickness (T) shall be defined as the diameter of the greatest inscribed sphere at any location in the casting when heat treated for mechanical properties.

Table D-1. Chemical Composition (Weight Percent). 1/

Element	Weight Percent (single values are maximums)	
	Grade HY-80	Grade HY-100
Carbon	0.20	0.22
Manganese	0.55 – 0.75	
Phosphorus	0.014	
Sulfur	0.005	
Silicon	0.50	
Nickel	2.75 – 3.25	3.00 – 3.50
Chromium	1.35 – 1.65	
Molybdenum	0.30 – 0.60	
Vanadium <u>2/</u>	0.03	
Titanium <u>2/</u>	0.02	
Copper <u>2/</u>	0.25	
Arsenic <u>2/</u>	0.025	
Tin <u>2/</u>	0.03	
Antimony <u>2/</u>	0.025	
Aluminum	0.04	
Nitrogen	100 ppm <u>3/</u>	
NOTES: <u>1/</u> For definition of lot for heat analysis, see D.4.4.1.2 and D.4.4.2. <u>2/</u> Elements shall not be intentionally added. <u>3/</u> Nitrogen content shall be determined with samples and instrumentation in accordance with ASTM E1019 or by other NAVSEA approved method. Nitrogen analysis may be performed during refining, in the ladle, or from samples removed from the final product.		

D.3.4 Tensile Properties. The material shall meet the tensile property requirements as specified in [Table D-2](#) after all heat treatments including, when approved by NAVSEA (see D.3.7.c), stress relief. Tensile properties shall meet the requirements in [Table D-2](#) at any location in the first article casting at an equivalent depth below the heat treated surface as the location of the tensile specimens in the prolongation or test block (see D.4.3.2.2).

Table D-2. Tensile Property Requirements.

Property	Required Value			
	Grade HY-80		Grade HY-100	
T ≤ 6 inches (152 mm) <u>1/</u> , <u>2/</u>				
Location	T/2 or 2 inches (51 mm)		T/2 or 2 inches (51 mm)	
Yield strength, 0.2% offset, ksi [MPa]	80 – 99.5 [552 – 686]		100 – 120 [690 – 827]	
Elongation in 2 inches, minimum percent	20		18	
Reduction of area, minimum percent	50		50	
6 inches (152 mm) < T ≤ 10 inches (254 mm) <u>1/</u>				
Location	T/4 or 2 inches (51 mm) <u>2/</u>	T/2 <u>3/</u>	T/4 or 2 inches (51 mm) <u>2/</u>	T/2 <u>3/</u>
Yield strength, 0.2% offset, ksi [MPa]	80 – 99.5 [552 – 686]	78 – 99.5 [538 – 686]	100 – 120 [690 – 827]	98 – 120 [676 – 827]
Elongation in 2 inches, minimum percent	20	18	18	15
Reduction of area, minimum percent	50	50	50	50
T > 10 inches (254 mm) <u>1/</u>				
Location	T/4	T/2 <u>3/</u>	T/4	T/2 <u>3/</u>
Yield strength, 0.2% offset, ksi [MPa]	80 – 99.5 [552 – 686]	76 – 99.5 [524 – 686]	100 – 120 [690 – 827]	93 – 120 [641 – 827]
Elongation in 2 inches, minimum percent	20	14	18	12
Reduction of area, minimum percent	50	50	50	45
NOTES:				
<u>1/</u> Ultimate tensile strength is reported for information only.				
<u>2/</u> For T up to and including 4 inches (102 mm), sample location shall be T/2. For T greater than 4 inches, sample location shall be T/4 or 2 inches (51 mm), whichever is greater.				
<u>3/</u> For T greater than 6 inches (152 mm), a second set of specimens shall be taken at T/2, unless otherwise specified (see D.6.2).				

D.3.5 Impact Properties. The material shall meet the impact requirements as specified in [Table D-3](#), after all heat treatments, including stress relief, when approved by NAVSEA (see D.3.7.c). The impact properties shall meet the requirements of [Table D-3](#) at any location in the first article casting at a depth below the heat treated surface equivalent to the location of the impact specimens in the prolongation or test block.

T9074-BD-GIB-010/0300 Rev 2

Table D-3. Impact Property Requirements

Impact Requirements at T/2 and T/4 Test Locations for Both HY-80 and HY-100, Unless Otherwise Specified in this Table <u>1/</u> , <u>2/</u> , <u>3/</u>			
	Charpy V-Notch Temp: -100 °F (-73 °C)	Charpy V-Notch Temp: 0 °F (-18 °C)	Dynamic Tear Temp: -40 °F (-40 °C)
HY-80/HY-100: T ≤ 4 inches (102 mm), T/2	50 ft-lb (68 J) Avg Min; % Shear Required	70 ft-lb (95 J) Avg Min; % Shear Required	For Info Only <u>4/</u>
HY-80/HY-100: T > 4 inches (102 mm), T/4 or 2 inches (51 mm), whichever is greater			
HY-80/HY-100: T < $\frac{5}{8}$ inch (16 mm)	50% Avg Min Shear	% Shear for Info Only	Not Required
HY-80: $\frac{5}{8}$ inch (16 mm) ≤ T ≤ 6 inches (152 mm)	50% Avg Min Shear	% Shear for Info Only	For Info Only <u>4/</u>
HY-100: $\frac{5}{8}$ inch (16 mm) ≤ T ≤ 4 inches (102 mm)			
HY-80: 6 inches (152 mm) < T < 12 inches (305 mm)	40% Avg Min Shear	% Shear for Info Only	For Info Only <u>4/</u>
HY-100: 4 inches (102 mm) < T < 12 inches (305 mm)			
HY-80/HY-100: T ≥ 12 inches (305 mm)	35% Avg Min Shear	% Shear for Info Only	For Info Only <u>4/</u>
Impact Requirements for Second Set of Specimens Taken at T/2 for Both HY-80 and HY-100 <u>1/</u> , <u>2/</u> , <u>5/</u>			
	Charpy V-Notch Temp: -100 °F (-73 °C)	Charpy V-Notch Temp: 0 °F (-18 °C)	Dynamic Tear Temp: -40 °F (-40 °C)
6 inches (152 mm) < T < 10 inches (254 mm), unless otherwise specified (see D.6.2)	50 ft-lb (68 J) Avg Min; % Shear Not Required	70 ft-lb (95 J) Avg Min; % Shear Not Required	For Info Only <u>3/</u> , <u>4/</u>
T ≥ 10 inches (254 mm)	30 ft-lb (41 J) Avg Min; % Shear Not Required	50 ft-lb (68 J) Avg Min; % Shear Not Required	For Info Only <u>3/</u> , <u>4/</u>
NOTES:			
<u>1/</u> Sampling and location of test specimens shall be as specified in D.4.3.2.2, D.4.3.2.5, and D.4.3.2.6 for first article and D.4.4.3, D.4.4.3.3, and D.4.4.3.4 for conformance inspection.			
<u>2/</u> Average of three specimens. No single Charpy V-notch energy value shall be below the minimum required average by more than 5 ft-lb (7 joules).			
<u>3/</u> The percent shear fracture shall be measured on each specimen.			
<u>4/</u> Data shall be forwarded to the NAVSEA Materials Engineering Group until otherwise advised by NAVSEA.			
<u>5/</u> Unless otherwise specified (see D.6.2), for T greater than 6 inches (152 mm), additional Charpy V-notch impact tests and dynamic tear tests shall be conducted at a depth of T/2.			

D.3.6 Additional Conformance Testing. When T exceeds 10 inches (254 mm) and when the CT exceeds 20 inches (508 mm), additional conformance testing may be required. If a supplier determines that their manufacturing method will lead to the use of a CT exceeding 20 inches (508 mm), the supplier must seek guidance from the procuring agent on whether or not additional conformance testing will be required, and what that conformance testing will entail.

D.3.7 Heat Treatment. The Contractor shall determine the detailed procedure that will produce castings that meet the mechanical requirements specified herein, with the following restrictions:

- a. The castings shall be quenched and tempered. The austenization, quenching, and tempering steps shall be preceded by homogenizing, normalizing, or annealing heat treatment(s). The tempering temperature shall be not less than 1190 °F (643 °C) for Grade HY-80 and 1150 °F (621 °C) for Grade HY-100. The tempering temperature for HY-80 and HY-100 at any location on the castings shall not exceed 1265 °F (685 °C). Multiple tempering cycles are permitted. After tempering and stress relief heat treatments (see D.3.7.c), all castings, including the test block(s) that

constitute the furnace load shall be removed from the furnace and rapidly cooled by water quenching at the same time (i.e., the same quench load). The use of more than one quench load for tempering and stress relief heat treatment of a single furnace load of castings is prohibited. Test blocks shall accompany the casting(s) they represent in all thermal treatments and shall be quenched at the same time (i.e., in the same quench load) as the casting(s) that they represent. All castings shall be arranged such that as far as possible they and the test block receive equal and uniform exposure to the quench media. Where it is determined not possible to arrange the test block where the casting and the test block receive equivalent exposure, the customer must be advised and agree to the quenching arrangement.

- b. Unless otherwise specified (see D.6.2), the tempering and stress relief heat-treat cycles shall have the following contact thermocouples attached to the casting(s) and the test blocks during the cycles: one contact thermocouple shall be placed on the thickest and thinnest sections of the castings in the furnace load, and on the casting or test block surface closest to a furnace burner. In addition, one contact thermocouple shall be placed on each test block representing the furnace load. Upon reaching the target tempering and stress relief heat treatment temperature, the temperatures on all casting and test block thermocouples shall be within ± 25 °F (± 14 °C) of the target temperature. In addition, the temperature on the thermocouple attached to the thickest section of the thickest casting in the load shall fall within ± 25 °F (± 14 °C) of the thermocouple attached to the thickest test block.
- c. Stress relief of Grade HY-80 and HY-100 is not permitted unless approved by NAVSEA on a case basis.
- d. For all heat treatment operations, castings shall be positioned and supported in such a manner to prevent shifting or falling from their initial set positions during the heat treatment process. In addition, during tempering and stress relief, castings shall be positioned in the furnace so that, in a direct fired furnace, burner flames and hot gases from these flames cannot impinge upon casting surfaces, and result in heating the castings above the maximum allowable tempering temperature. As a minimum, the castings shall be supported in the furnace by a grating/floor structure or similar structure that ensures that the castings cannot fall or shift outside of the furnace working zone and be exposed to burner flames or hot gases. The structure supporting the grating/floor in the furnace, such as pylons, sawhorses, and racks, shall be in a permanent/semi-permanent position and shall not deflect flames and hot gases onto casting surfaces.
- e. In addition to the requirements of 3.5 for batch-type furnaces, the heat treatment record shall also include digital photographs and sketches providing sufficient accuracy to recreate positions and orientations of the casting in the furnace at future dates. The sketches shall identify every part in the load uniquely according to a vendor's internal tracking methodology. The photographs in the heat treatment record shall be of the furnace car casting-load immediately prior to entering and immediately after leaving the furnace for the tempering cycle(s) and stress relief. The sketches in the heat treatment record shall include placement of castings, casting-support structure (i.e., pylons, sawhorses, racks, etc.) on the furnace car, placement of the burners in the furnace, and the distances and orientations of the castings and support structure with respect to the burners. The verification of inspection record shall validate the casting was loaded in accordance with the sketches and/or photographs in the heat treatment record. The verification of inspection record shall also validate the sketch(es) and photograph(s) are consistent with all support structure and casting positions during the tempering heat treatment.
- f. The quench tank facility used for quenching after austenitizing shall be of sufficient capacity and design to provide multi-directional water flow (i.e., from at least three directions, or other equivalent designs based on data and on results of first article testing) to provide for effective quenching of the largest castings to be heat treated. The effectiveness of the quench tank facility in terms of capacity and water flow shall be demonstrated during first article testing where both the largest size (i.e., thickness and complexity) casting and the accompanying test blocks are demonstrated to meet the minimum mechanical property requirements. The maximum quench tank water temperature at the initiation of the quenching operation shall not exceed 80 °F (27 °C). A process shall be put in place to maintain the effectiveness (e.g., flow rate and water capacity) of the quench tank similar to that used during the first article qualification.
- g. For HY-80 and HY-100, castings and test blocks shall be given a hydrogen diffusion anneal (i.e., thermal soak) at 575 °F (302 °C) and for a time as specified below in [Table D-4](#). Alternate hydrogen soaking parameters shall be qualified. The proposed test plan to establish alternate soaking parameters shall be submitted to NAVSEA for approval.

Table D-4. Hydrogen Soak Time.

T, inches (mm)	Minimum Soak Time, hours
<8 (203)	24
8 (203) – 9¼ (235)	150
>9¼ (235) – 11 (279)	300
>11 (279)	450

D.3.7.1 Simulated Stress Relief. When a simulated stress relief is specified (see D.6.2), a prolongation or test block as specified in D.4.3.1.2 shall be subjected to the stress relief thermal cycle based on the tempering temperature of the materials (see D.3.2), shall be tested for tensile and impact properties in accordance with D.4.4, and shall meet the requirements specified in D.3.4 and D.3.5. The stress relief thermal cycles (including cooling rates) shall be specified (see D.6.2). Stress relief shall be specified only when necessary to meet machining tolerances, and approved by NAVSEA (see D.3.7.c).

D.3.7.1.1 Verification of Properties. When specified (see D.6.2), a representative sample, in the form of a prolongation or test block, as specified in D.3.7.1, shall be forwarded with the material to verify properties, after the proposed stress relief, as specified in the applicable fabrication document.

D.3.8 Explosion Testing. Explosion testing is required as part of first article testing and is not required for conformance testing. Two explosion crack starter tests are required for first article testing. Both specimens shall conform to the crack starter configuration requirements on [Figure L-8](#) and meet the explosion crack starter requirements in Appendix L. When explosion bulge type testing is specified (see D.6.2), testing shall be in accordance with Appendix L and explosion bulge tests shall continue until both a minimum of four shots and a minimum of 10 percent reduction in thickness is obtained on one or both sides.

D.3.9 Cleaning. Prior to heat treatment for properties, the castings shall have the heads, risers, padding, and gates removed. Removal of all burn-in, burn-on, penetrated sand, cutting or arcing slag, and adhering external chills and arbors shall also be done prior to heat-treat for properties. Prior to the final inspection and the Nondestructive Test (NDT) inspection, all sand, scale, fins, and rough spots shall be removed by mechanical means and meet ACI - surface indicator scale (SIS-3) or better. Gouges on flame or arc cut surfaces shall be repaired in accordance with the specified fabrication document (see D.6.2). Gouges shall not exceed ¼-inch (3-mm) depth and shall not result in the casting thickness falling below the minimum design dimension of the component.

D.3.9.1 Chills and Chaplets. Unless otherwise specified (see D.6.2), chills and chaplets shall not remain with the casting.

D.3.10 Internal and External Soundness. Castings and test blocks shall be of uniform quality and condition as determined by visual examination, radiographic testing, magnetic particle inspection, and ultrasonic testing as permitted in the applicable fabrication document. Nondestructive inspection shall be performed in accordance with T9074-AS-GIB-010/271. The extent of inspection and the acceptance criteria shall be in accordance with the applicable fabrication document and the contract or purchase order (see D.6.2).

D.3.11 Repair of Defects. Welding may be used to repair defects in accordance with the applicable fabrication document and as specified herein. The applicable fabrication document shall be as specified (see D.6.2). Defects not requiring welding may be ground or chipped out provided the width of the defective area is at least three times its depth and gradually tapered into the defect and the design thickness is not violated. The locations of all nominal and special weld repairs shall be maintained by the foundry and shall be provided with the casting, unless otherwise specified (see D.6.2). Repair methods and inspection requirements shall be in accordance with the applicable fabrication document and as specified herein. Specific requirements for weld repairs are provided (see D.3.11.1, D.3.11.2, and D.3.11.3).

D.3.11.1 Prohibited Filler Metals. MIL-120S-1 and MIL-12018-M2 or equivalent strength welding consumables shall not be used for any welding including repair welding and weld build-up.

D.3.11.2 Minor Repairs. Minor repairs in HY-80 and HY-100 castings may be performed using MIL-10718-M or MIL-100S type electrodes. Minor repairs are repairs of surface defects for which the excavations do not exceed the following limits:

- a. The maximum depth does not exceed ½ inch or 20 percent of the casting thickness, whichever is less.
- b. Individual repair areas do not involve more than 2 percent of the casting surface.
- c. The total repair area does not exceed 10 percent of the casting surface.

HY-80 steel preheat/interpass temperature and heat input limitations per the fabrication document specified in D.6.2 shall be required. MIL-10718-M or MIL-100S type electrodes shall be purchased to T9074-BC-GIB-010/0200. Specific welding procedures with the above guidelines shall be submitted to the purchaser for approval. Furthermore, the type of welding filler material used to accomplish minor weld repairs shall be identified in the welding procedures submitted to the purchaser for approval.

D.3.11.3 Nominal and Special Repairs. Nominal and special repairs in HY-80 castings may be performed using MIL-10718-M or MIL-100S type electrodes that are purchased to T9074-BC-GIB-010/0200, unless otherwise approved. Nominal and special repairs in HY-100 castings may be performed using only MIL-10718-M electrodes, except when the casting thickness at the repair is greater than or equal to 1 inch (25 mm), MIL-100S type electrodes may be used. Electrodes used for these repairs shall be purchased to T9074-BC-GIB-010/0200. Nominal and special repairs of HY-80 and HY-100 castings are required for defects that exceed the limitations of minor repairs as described in D.3.11.2. Such repairs are limited to the following local casting thickness (not defect depth) and heat input combinations:

Local Casting Thickness, inch (mm)	Maximum Heat Input (kJ/inch)
$\frac{1}{2}$ (14) to $<\frac{5}{8}$ (16)	35
$\frac{5}{8}$ (16) to $<\frac{3}{4}$ (19)	45
$\geq\frac{3}{4}$ (19)	55

D.3.12 Dimensions and Tolerances. The Contractor shall provide heat treated castings that can be machined to the finished dimensions within the specified tolerances without further straightening. When required, layout points shall be incorporated in the castings and shall be shown on the applicable drawings. Castings shall not be provided excessively oversize or overweight.

D.3.13 Marking. The castings shall be identified with the Contractor's name or trademark and a serial number, which will positively identify the casting to pattern, part number, and melt from which they were poured and the lot with which they were heat treated. Markings shall be placed in areas which are least stressed in service and will not be machined off in finishing. The locations of the markings shall be as shown on the drawings (see D.6.2).

D.3.14 Hardness. The Brinell hardness (HB) at all casting locations shall fall within the range of 200 to 260 HB for HY-80 and within 230 to 290 HB for HY-100.

D.4 VERIFICATION.

D.4.1 Responsibility for Inspection. See 4.1.

D.4.2 Classification of Inspections. The inspections specified herein are classified as follows:

- a. First article inspection (see D.4.3).
- b. Conformance inspection (see D.4.4).

T9074-BD-GIB-010/0300 Rev 2

D.4.3 **First Article Inspection.** First article inspection shall consist of the samples, examinations, and tests specified in D.4.3.1 through D.4.3.2 and in [Table D-5](#) (see D.6.3, 4.3, and Appendix L).

Table D-5. First Article and Conformance Inspection Requirements.

Examination and Tests	Requirement	Test Method	First Article	Conformance
Chemical analysis	D.3.2	4.5.1 and D.4.4.2	X	X
Tensile properties	D.3.4	4.5.2	X	X
Explosion	D.3.8	4.5.5	X	---
Hardness	D.3.14	D.4.3.2.9 and D.4.4.4.1	X	X
Impact Properties				
Charpy V-notch	D.3.5	4.5.3	X	X
Dynamic tear	D.3.5	4.5.4	X	X
Examination				
Surface quality	D.3.9 and D.3.10	D.6.2.j and D.6.2.1	X	X
Dimensional	D.3.12	---	X	X
Internal soundness	D.3.10	D.4.3.2.1 and D.4.4.4	X	X

D.4.3.1 **First Article Samples.** First article samples shall be as specified in D.4.3.1.1 through D.4.3.1.3.

D.4.3.1.1 **Castings.** The first article sample shall be a casting representative of the largest size (i.e., largest section thickness) to be cast of HY-80 or HY-100 at the facility, and approved by NAVSEA. One HY-80 or HY-100 casting of largest size and sufficient complexity to demonstrate the capability to provide castings with acceptable chemical composition and mechanical properties throughout the volume of the casting shall be cast for first article inspection. [Figure D-1](#) provides guidance on a suitable thick/complex first article casting to demonstrate capability of a foundry in the weight category of either at or below, or above 15,000 lbs (6810 kg) as illustrated in the drawings on [Figure D-1](#). When approved by NAVSEA, the foundry may use alternate first article casting(s) to those illustrated on [Figure D-1](#) to demonstrate capability. Unless otherwise specified (see D.6.2), HY-80 and HY-100 shall be tested separately.

D.4.3.1.1.1 **Capability and Feasibility of Casting Design.** Prior to submission of a quote of a new design by a supplier, the purchaser shall integrate with the qualified foundry industrial base and ensure design manufacturability with the expectation of achieving acceptable properties throughout the cast article. Where agreement on casting manufacturability cannot be reached to support production, the purchaser shall notify NAVSEA.

D.4.3.1.1.2 **Prolongation or Test Block.** All castings shall require representative prolongation(s) or test block(s) according to the requirements herein.

D.4.3.1.2.1 **For Castings 6 Inches (152 mm) and Greater in Thickness.** Unless otherwise specified by the contract or order (see D.6.2), representative prolongation(s) or test block(s) shall be integrally cast with the casting(s) it represents, or attached in a manner approved by the purchaser to the casting being represented by the prolongation or test block. The casting and prolongation or test block representing the casting shall be heat treated (including quenching) together through all thermal cycles. The test block shall be attached by an appendage that ensures the mass of the test block is thermally separated from the casting mass. The prolongation or test block shall be located such that the prolongation or test block soak time and temperature during all heat treatments are the same as the casting, and that during quenching operations the prolongation or test block receives a uniform exposure to the quench medium that is equivalent to that received by the thickest part of the casting. When the test block remains attached to the casting, it shall not obstruct quenchant flow through all thermal cycles.

D.4.3.1.2.2 **Prolongation or Test Block Size.** The size of the prolongation or test block shall be in proportion to the diameter (T) of the largest sphere that can be inscribed in any cross-section of the as-heat-treated casting. The minimum dimensions of a prolongation or test block are specified in [Table D-6](#).

Table D-6. Dimensions of Test Blocks.

Test Block/Prolongation Sizes	
T, inches (mm)	Test Block Dimension, inches (mm) <u>1/</u>
Under 1 (25)	1 by 7 by 7 (25 by 178 by 178)
1 to 2, exclusive (25 to 51)	T by 4.5T by 4.5T
2 to 4, exclusive (51 to 102)	T by 3T by 3T
4 and over (102)	T by T by 6(T) ^{1/2}
NOTES: <u>1/</u> Dimensions specified are minimums. The dimensions, particularly the length or longest dimension on T of 4 inches and over, may be increased in order to secure a practical prolongation or test block for heat treating and cutting tests and for possible retest, if necessary. Extra test block(s) may be cast for possible retest.	

D.4.3.1.2.3 Prolongation or Test Block Heat Treatment. Prolongations/test blocks shall accompany the casting through all the heat treatment cycles, including quenching, and shall receive the same thermal treatment as the parent castings. For austenitizing and tempering, the prolongation or test block shall be located in the furnace so that air circulation around it is not impeded by the castings and to ensure that the prolongation or test block temperature and soak time are the same as that of the castings. For quenching, the test block shall be located such that, as far as possible, the prolongation or test block receives uniform exposure to the quench media equivalent to that received by the casting.

D.4.3.1.3 Explosion Test Specimens. A minimum of 12 plates with final dimensions 2 by 16 by 55 inches (51 by 406 by 1397 mm) shall be cast to evaluate the explosion properties.

D.4.3.2 First Article Examinations and Tests. First article inspection shall consist of the examination and tests of D.4.3.2.1 through D.4.3.2.9.

D.4.3.2.1 Examination. The castings shall be inspected to ensure soundness and freedom from defects by the same method specified for the production castings (see D.3.10). If no method is specified, radiography to the applicable category of T9074-AD-GIB-010/1688 shall be used.

D.4.3.2.2 Test Specimen Location. Test specimens for measuring tensile and impact properties for each of the following thicknesses shall be taken from each casting and each casting prolongation or test block for first article inspection. For T up to and including 4 inches, test specimens shall be taken such that one surface of the specimen is at a minimum depth of T/2 from all heat treated surfaces. For T greater than 4 inches (102 mm) and less than or equal to the maximum thickness approved in first article testing, test specimens shall be taken at a minimum depth of T/4 or 2 inches (51 mm), whichever is greater, from all heat treated surfaces. [Figure D-2](#) is provided for test specimen location guidance.

D.4.3.2.2.1 Test Specimen Location in Sections Greater than 6 Inches Thick. Unless otherwise specified by the purchaser (see D.6.2), for all castings of T greater than 6 inches (152 mm), test specimens shall also be taken such that one surface of the specimen is at a minimum depth of T/2 from all other heat treated surfaces, and, as a minimum, shall exhibit test values no lower than those specified.

D.4.3.2.3 Chemical Analysis. The manufacturer shall demonstrate that the casting process is capable of providing castings that meet the chemical composition requirements throughout the casting and that castings are free from surface contamination by carbon, sulfur and, when specified (see D.6.2), other detrimental elements. Chemical analyses shall be performed on each tensile specimen from each of the locations specified in D.4.3.2.2 and a prepared heat analysis sample. Specimens shall meet the requirements specified in D.3.2 and the conditions in D.4.5.1. Chemical analysis for near-surface carbon, sulfur, and other harmful contamination (see D.6.2) shall be performed after final heat treatment on a protruding test button on the surface of the prolongation, or test block representing the thickest section of the casting. The button shall be large enough to provide sufficient material to accomplish all required tests. The button will be removed after the last heat-treat cycle, and the analysis made on the removed button at a depth of 0.015, 0.03, 0.05, 0.10, and 0.20 inch (0.4, 0.8, 1.3, 2.5, and 5 mm) beneath the casting surface. The analysis for all elements (i.e., carbon, sulfur and other specified harmful contaminants) shall meet the requirements specified in D.3.2. Analysis shall be performed using spectrographic methods on the surface, or by combustion analysis of drillings or millings taken from the surface, at the specified depth ± 0.010 inch (± 0.3 mm). In addition to testing the button from the prolongation or test block, chemical analyses for carbon, sulfur, and other specified harmful contamination shall be performed on sample material, drillings, or filings removed from the surface

T9074-BD-GIB-010/0300 Rev 2

of the first article casting. Surface samples shall be taken from the prototype casting at depths and locations approved by NAVSEA that represent the thickest, thinnest, and cope surface sections of the castings. Additionally, NAVSEA shall take into account possible sources of harmful contamination (see D.6.2) in the manufacturer's casting process and determine the number of test locations to be included in first article testing. Based on results of these tests, NAVSEA will determine if sampling for surface chemical composition is required on production castings.

D.4.3.2.4 Tensile Test. One tensile test specimen shall be taken at each location specified in D.4.3.2.2. Specimens shall meet the requirements specified in D.3.4.

D.4.3.2.5 Charpy V-Notch. A set of three Charpy V-notch impact specimens from each of the locations specified in D.4.3.2.2 shall be tested at 0 °F (minus 18 °C), minus 40 °F (minus 40 °C), and minus 100 °F (minus 73 °C). The specimens shall meet the requirements specified in D.3.5.

D.4.3.2.6 Dynamic Tear. Two dynamic tear test specimens shall be taken from both the casting and the prolongation or test blocks at each of the locations specified in D.4.3.2.2. Test results shall be recorded and shall be provided for information (see [Table D-3](#)).

D.4.3.2.7 Transition Test Curve. Charpy V-notch and dynamic tear transition curves shall be developed from impact specimens taken from the thickest section of the first article casting and from the test block per D.4.3.2.2 and tested at minus 100 °F (minus 73 °C), minus 80 °F (minus 62 °C), minus 40 °F (minus 40 °C), 0 °F (minus 18 °C), and 30 °F (minus 1 °C). A minimum of three specimens shall be tested at each temperature.

D.4.3.2.8 Explosion Test. The explosion test specimens specified in D.4.3.1.3 shall meet the requirements specified in D.3.8 when tested in accordance with 4.5.5.

D.4.3.2.9 Hardness Testing. Each first article casting and prolongation or test block casting shall be hardness tested. Hardness tests shall be performed on each of the protruding buttons used for the performance of surface chemical analyses. The number of tests and the location of the tests shall be approved by NAVSEA and shall meet the requirements of D.3.14.

D.4.3.2.10 First Article Inspection Report. See 3.1.

D.4.4 Conformance Inspection. Conformance inspection (i.e., inspections of production lots) shall consist of the examination and tests of D.4.4.2 through D.4.4.4.1 and [Table D-5](#). A prolongation or test block(s) (see D.4.3.1.2) shall accompany the lot or casting through all heat treatment cycles and shall receive the same thermal treatment as the parent casting or lot. Two sizes of prolongations/test blocks shall be heat treated with each lot. One shall represent the maximum T of the largest casting in a lot and one shall represent the maximum T of the smallest casting in a lot. The terms "large" and "small" casting are defined by the respective T of each. Where castings representing a lot are identical with regard to minimum or maximum T, one prolongation or test block will suffice. For castings less than 6 inches thick, an integrally cast prolongation or test block is not required, unless otherwise specified (see D.6.2), and a separately cast test block may be used.

D.4.4.1 Lot Definitions.

D.4.4.1.1 Lot for Tension and Impact Tests. Castings produced from one heat or melt and heat treated in the same furnace at the same time (i.e., the same furnace load) shall constitute a lot.

D.4.4.1.2 Lot for Examination and Inspections. Each casting shall constitute a lot.

D.4.4.1.3 Lot for Chemical Composition. Lot for chemical composition shall be as defined in 4.4.1.1.

D.4.4.2 Sampling for Chemical Analysis. Samples for chemical analysis shall be taken as follows. First, test samples shall be taken during the pouring of the heat at a time that, in the Contractor's judgment, best represents the composition of the heat. In the case where heat analysis samples are lost or inadequate, or when it is evident that the sample does not truly represent the heat, representative samples may be taken from the castings. The analysis shall meet the specified limits for heat analysis. Second, test samples shall be taken from one of the broken tensile specimens from each prolongation or test block for product analysis. Third, test samples for carbon, sulfur, and other specified harmful contaminants shall be taken from the protruding button on the surface of each prolongation or test block casting, when required based on first article testing (see D.4.3.2.3). These analyses shall meet the specified limits in D.3.2.

D.4.4.3 Sampling for Mechanical Tests. Prolongations/test blocks in accordance with D.4.3.1.2 shall be provided for mechanical tests. Test specimen location shall be in accordance with D.4.3.2.2. Additionally, the test specimens shall be grouped together around the mid-length of the test block with the tensile and DT test specimens taken nearest the mid-length.

D.4.4.3.1 Sampling for Mechanical Tests Following Simulated Stress Relief. When specified (see D.6.2), sample material from a prolongation or test block shall be subjected to simulated stress relief operations after quenching and tempering, but prior to testing for conformance to the mechanical property requirements of D.3.4 and D.3.5. The sample

material shall not be removed from the prolongation or test block prior to quenching and tempering. The total time at temperature and cooling rate for the simulated stress relief operation shall be as specified (see D.6.2). The cooling rate and the maximum and minimum time at temperature used on the sample material shall be incorporated in the test certification, if applicable, along with the destructive test results.

D.4.4.3.2 Sampling for Tensile Test. One specimen shall be taken from each of the prolongation or test blocks representing the lot at the locations specified in D.4.3.2.2.

D.4.4.3.3 Sampling for Charpy V-Notch Tests. Three Charpy V-notch test samples shall be taken for each test temperature from each of prolongation or test blocks representing the lot at the locations specified in D.4.3.2.2.

D.4.4.3.4 Sampling for Dynamic Tear Test. Two samples shall be taken from each of the prolongation or test blocks representing the lot at the locations specified in D.4.3.2.2.

D.4.4.4 Nondestructive Testing. Each casting shall be examined for conformance to the requirements of the applicable fabrication documents (see 6.2).

D.4.4.4.1 Hardness Testing. Each casting shall be hardness tested after final heat treatment by an approved and qualified method at locations representative of the maximum and minimum thickness (see D.3.14).

D.4.5 Test Procedures. See [Table D-5](#) and 4.5.

D.4.5.1 Chemical Analysis. If any analysis, except for nitrogen, fails to conform to D.3.2, and product analyses are determined, the product analyses shall be used to determine acceptance or rejection.

D.5 PACKAGING.

See Chapter 5.

D.6 NOTES.

D.6.1 Intended Use. Grade HY-80 and Grade HY-100 alloy steel castings are intended for critical structural applications where a weldable, notch-tough, high-strength material is required. References to the Contractor in this application are meant to apply to a specific steel casting. The use of Grade HY-80 and HY-100 steel in fabricated structures or equipment entails much more than a material specification, and caution is advised in the areas of welding, fabrication, and nondestructive testing. Applicable fabrication documents should be required for any construction with these materials.

D.6.2 Acquisition Requirements. Acquisition documents must specify the following:

- a. Title, number, and date of this specification.
- b. Grade required (see D.1.2).
- c. Specified additional refining processes (see D.3.1) that may be necessary to comply with [Table D-1](#), note 3.
- d. If locations on the casting other than those specified require contact thermocouples (see D.3.7.b).
- e. When a simulated stress relief sample is required, the number of thermal cycles, the heating and cooling rates, and time at temperature (see D.3.7.1).
- f. When a representative sample is to be forwarded to verify properties after stress relief (see D.3.7.1.1).
- g. When first article testing requires explosion bulge type tests in addition to crack starter type tests (see D.3.8).
- h. When padding added by the foundry may be allowed to remain for removal by subsequent machining operations (see D.3.9).
- i. Applicable fabrication document required (see D.3.9 and D.3.11).
- j. When chills and chaplets may remain with the casting (see D.3.9.1).
- k. The degree of inspection and the acceptability requirements (see D.3.10).
- l. When a record of weld repair locations is not required (see D.3.11).
- m. Locations of markings shown on drawings (see D.3.13).
- n. When HY-80 and HY-100 castings are to be first article tested together (see D.4.3.1.1).

T9074-BD-GIB-010/0300 Rev 2

- o. When prolongations/test blocks for castings 6 inches (152 mm) and greater in thickness are not required to be integral cast or attached in a manner approved by the purchaser (see D.4.3.1.2).
- p. When specimens shall not be taken at T/2 for thick sections (see D.4.3.2.2.1 and [Table D-2](#)).
- q. When specimens from T/2, taken from castings $T > 6$ inches and less than or equal to maximum thickness qualified by first article inspection approval, shall have minimum tensile and impact toughness requirements other than specified (see D.4.3.2.2.1).
- r. Elements other than carbon and sulfur considered harmful contaminants and requiring surface chemical analysis (see D.4.3.2.3).
- s. Whether an integrally cast prolongation or test block is required for castings less than 6 inches thick (see D.4.4).
- t. When sample material is to be subjected to simulated stress relief (see D.4.4.3.1).
- u. Total time at temperature and cooling rate for simulated stress relief (see D.4.4.3.1).
- v. Location of the raised Brinell test pads (see D.4.4.4.1).
- w. When first article test data for HY-100 Grade material may not be used for first article approval of HY-80 (see D.6.3.1).
- x. When HY-100 has passed first article testing, whether explosion testing of HY-80 is required (see D.6.3.1).

D.6.3 First Article. See 6.3.

D.6.3.1 Approval for Different Grade Material. Unless otherwise required by the contract or purchase order (see D.6.2), when Grade HY-100 cast material has met first article test requirements, Grade HY-80 material may be reviewed for first article approval by submitting the required first article data, exclusive of explosion tests.

D.6.3.2 Receipt Inspection. The castings will be subject to receipt inspection by the contracting activity to verify conformance to all requirements specified herein. Castings not conforming to the requirements specified herein may be rejected by the contracting activity. The Contractor may verify the results of the contracting activity's receipt inspection. It is the responsibility of the contracting activity to determine the acceptability of the castings for the intended application.

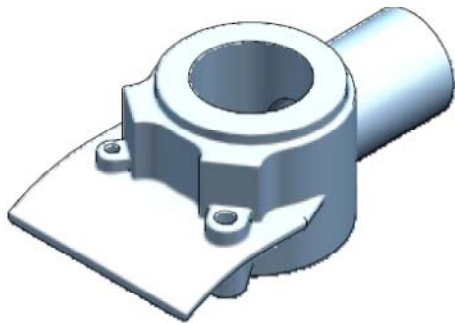

ISOMETRIC A-A

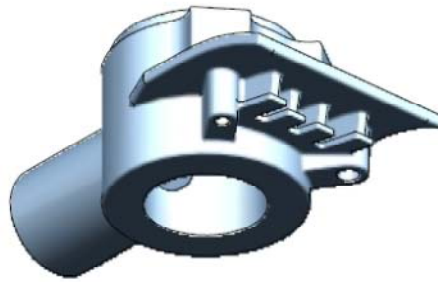

ISOMETRIC B-B

	MINIMUM DIMENSION	MAXIMUM DIMENSION
A	$\varnothing 2T$	$\varnothing 5T$
B	$3.50T$	$5T$
C	$4T$	$6.34T$
D	$2T$	$3.50T$
E	$\varnothing 1.88T$	$\varnothing 2.75T$
F	$2.75T$	$3.75T$
G	$1.25T$	$1.75T$
H	T	$1.75T$
J	$1.38T$	$1.63T$
K	$R 3.77T$	$R 6.20T$
M	$.19T$	$.25T$
N	$.40T$	$.50T$
P	$.28T$	$.23T$
R	$.62T$	$1.13T$
U	$.31T$	$.56T$
V	$.25T$	$.50T$

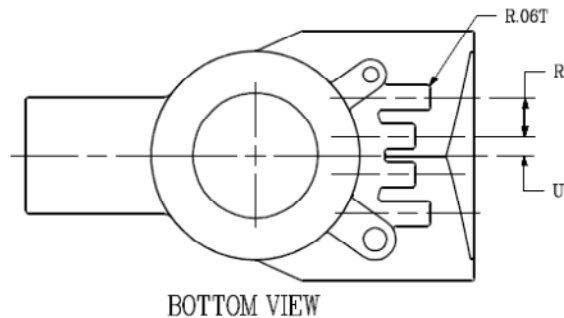
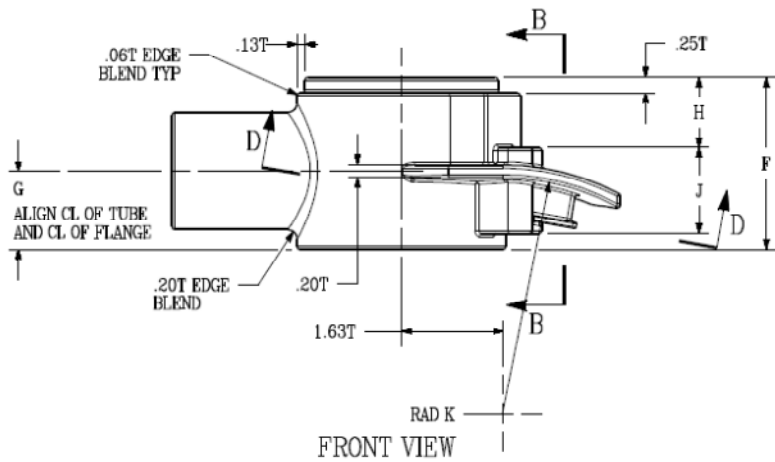
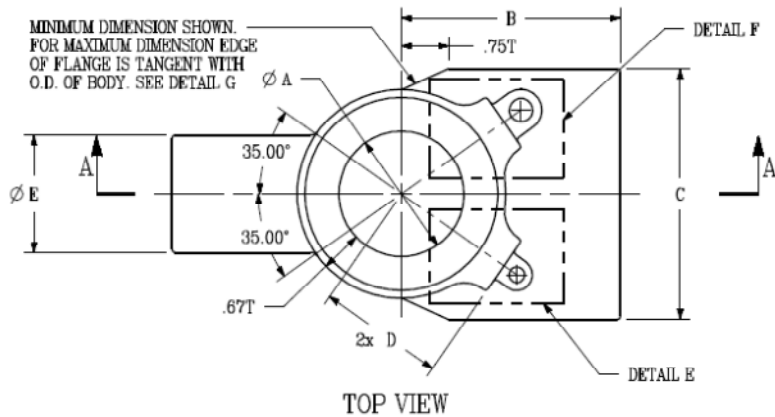

This figure provides guidance on a suitably thick and complex casting for qualification to this technical publication. Minimum and maximum dimensioning of this drawing is provided such that a foundry can select dimensioning appropriate for the capacity of their facility. It is intended that a foundry will select a casting that will demonstrate their maximum capabilities.

Figure D-1. Sample First Article Casting.

T9074-BD-GIB-010/0300 Rev 2

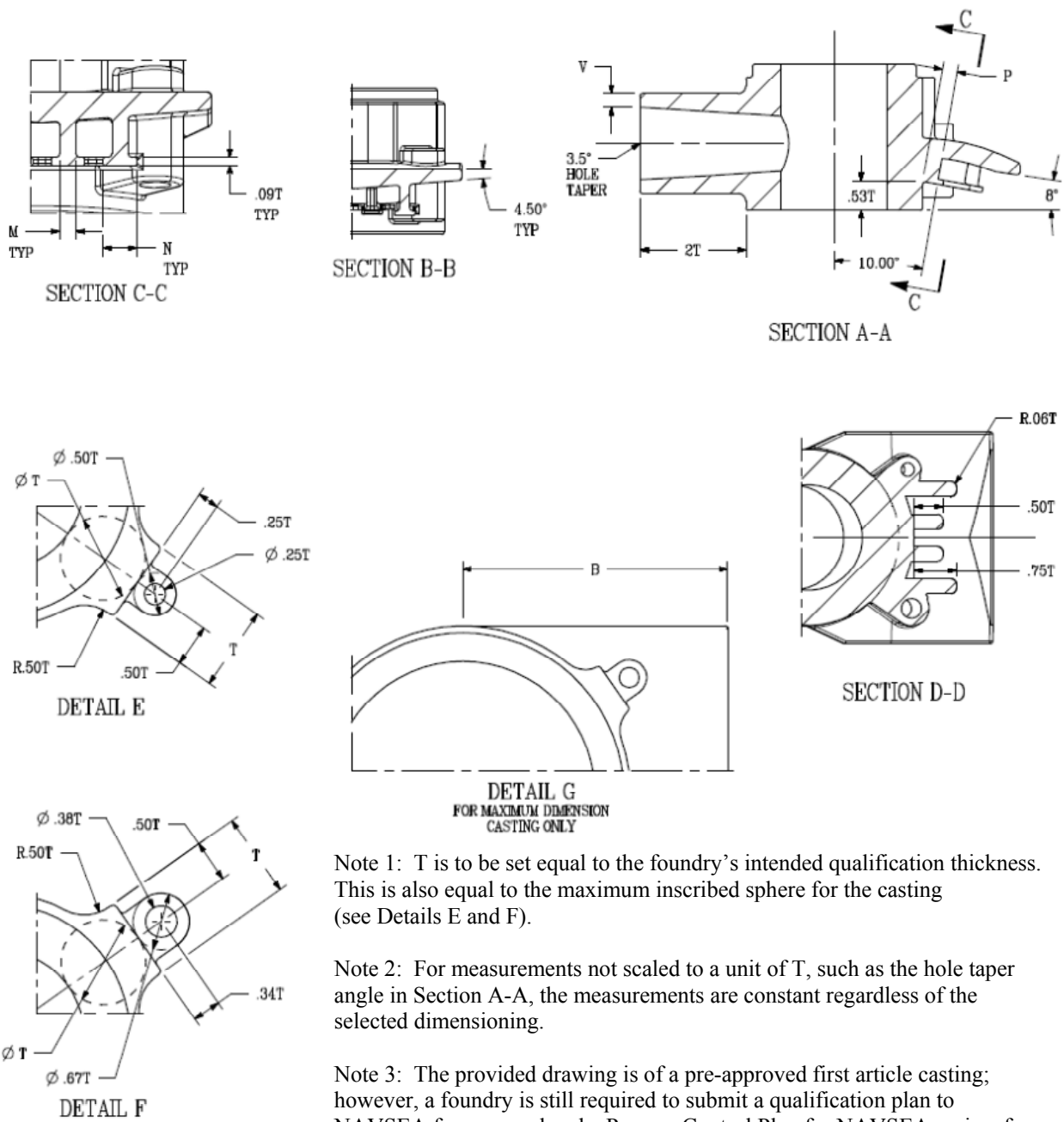

Note 1: T is to be set equal to the foundry's intended qualification thickness. This is also equal to the maximum inscribed sphere for the casting (see Details E and F).

Note 2: For measurements not scaled to a unit of T, such as the hole taper angle in Section A-A, the measurements are constant regardless of the selected dimensioning.

Note 3: The provided drawing is of a pre-approved first article casting; however, a foundry is still required to submit a qualification plan to NAVSEA for approval and a Process Control Plan for NAVSEA review for adequacy per the requirements of 3.1 and 4.3.2.

Note 4: The foundry may use an alternate first article casting with NAVSEA approval.

Note 5: At T equal to 13 inches, the minimum and maximum dimensioning result in a finished machined weight of 14,445 lbs and 38,295 lbs, respectively.

Figure D-1. Sample First Article Casting – Continued.

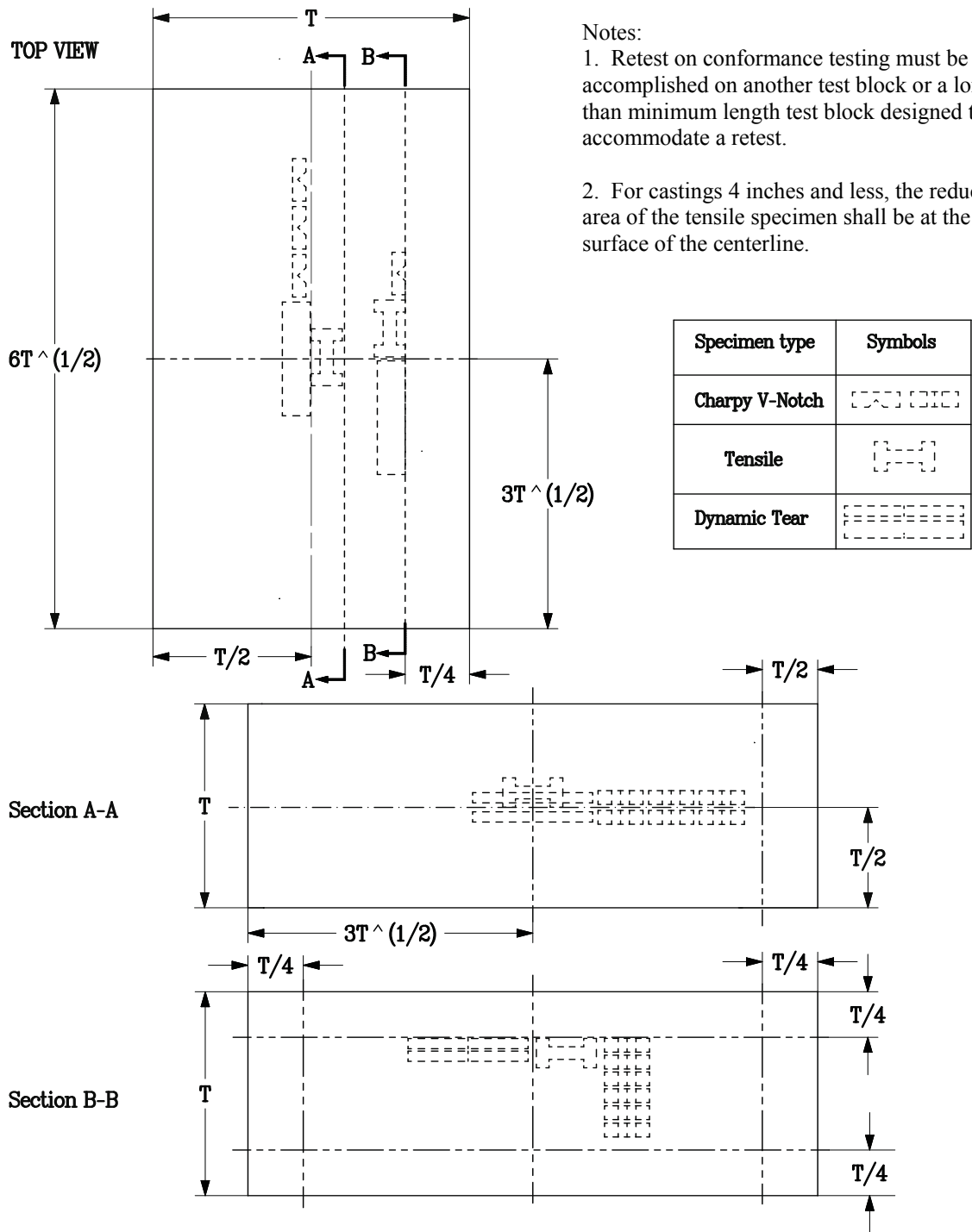

Figure 1. Schematic diagram of test specimen location for castings greater than 6 inches in thickness. Specimens in relation to one another are not to scale.

Figure D-2. Schematic Diagram of Test Specimen Location for Castings Greater than 6 Inches in Thickness. Specimens in relation to one another are not to scale.

T9074-BD-GIB-010/0300 Rev 2

THIS PAGE INTENTIONALLY LEFT BLANK

APPENDIX E (23009) STEEL FORGINGS, ALLOY, HIGH YIELD STRENGTH (HY-80 AND HY-100)

E.1 SCOPE.

E.1.1 Scope. This appendix covers Grade HY-80 and Grade HY-100 alloy steel forgings intended for critical structural applications where a weldable, high-strength, high-toughness material is required.

E.1.2 Classification. Steel forgings shall be of the following grades, as specified (see E.6.2).

Grade HY-80 - 80,000 lb/in² (80 ksi) [552 MPa] tensile yield strength, minimum.

Grade HY-100 - 100,000 lb/in² (100 ksi) [690 MPa] tensile yield strength, minimum.

E.2 APPLICABLE DOCUMENTS.

See Chapter 2.

E.3 REQUIREMENTS.

E.3.1 Forging Process. The forging process shall be as specified in E.3.1.1 and E.3.1.2.

E.3.1.1 Forging Ratios. The original cross-sectional area of the ingot shall be at least three times the cross-sectional area of the main body of the forging. Where an upsetting operation is employed or the forging is expanded on a mandrel, the metal shall be worked to an extent not less than that indicated above, but there is no fixed ratio between the cross-sectional area of the ingot and that of the forging.

E.3.1.2 Boring of Forgings. Where the forgings are to be bored, the centerline of the ingot shall be in the discarded metal removed from the bore.

E.3.1.3 Forging Thickness Definition. The forging thickness (T) shall be defined as the diameter of the greatest inscribed sphere in the heaviest cross-section in the as-heat-treated condition.

T9074-BD-GIB-010/0300 Rev 2

E.3.2 Chemical Composition. The chemical composition, heat, and product shall be as specified in [Table E-1](#). Unless otherwise specified (see E.6.2), product analysis tolerances shall conform to those specified in ASTM A788.

Table E-1. Chemical Composition (Weight Percent). 1/, 4/

Element	Weight Percent (single values are maximums)	
	Grade HY-80	Grade HY-100
Carbon	0.12 – 0.18	0.12 – 0.20
Manganese	0.10 – 0.40	
Phosphorus	0.015	
Sulfur	0.004	
Silicon <u>2/</u>	0.15 – 0.35	
Nickel	2.50 – 3.25	2.75 – 3.50
Chromium	1.35 – 1.80	
Molybdenum	0.30 – 0.60	
Vanadium <u>3/</u>	0.03	
Titanium <u>3/</u>	0.02	
Copper <u>3/</u>	0.25	
Arsenic <u>3/</u>	0.025	
Tin <u>3/</u>	0.030	
Antimony <u>3/</u>	0.025	
NOTES: <u>1/</u> For definition of lot for heat analysis, see E.4.4.1. <u>2/</u> When vacuum carbon deoxidation is used, the minimum silicon content may be reduced to 0.08 percent. <u>3/</u> Element shall not be intentionally added. <u>4/</u> When specified by the purchaser (see E.6.2), the maximum carbon equivalent of the heat shall be no greater than 0.72 percent using the carbon equivalent formula specified by the purchaser.		

E.3.3 Tensile Properties. The material shall meet the tensile property requirements as specified in [Table E-2](#) after all heat treatments including stress relief. The tensile properties measured at any location in the first article forging at a depth below the heat treated surface equivalent to the location of the tensile specimens in the prolongation/test block shall meet the requirements of [Table E-2](#) (see E.4.3.1.4).

Table E-2. Tensile Property Requirements. 1/

Property		Required Value	
		Grade HY-80	Grade HY-100 2/
Yield strength, 0.2 percent offset, (ksi) [MPa]		80 – 99.5 [552 – 686]	100 – 115 [690 – 793]
Ultimate tensile strength, ksi		Information only	Information only
Elongation in 2 inches (51 mm) (minimum percent)	Longitudinal	20.0	18.0
	Transverse	18.0	16.0
Reduction of area (minimum percent)	Longitudinal	55.0	50.0
	Transverse	50.0	45.0
NOTES:			
1/ Location of tensile specimens shall be as specified in E.4.3.1.4 and E.4.4.3.			
2/ Unless otherwise specified (see E.6.2), T/2 specimens in over 8-inch (203-mm) thick HY-100 forgings shall exhibit a minimum average yield strength not lower than 96 ksi [662 MPa].			

E.3.4 Impact Properties. Unless otherwise specified (see E.6.2), the material shall meet the impact requirements as specified in [Table E-3](#) after all heat treatments including stress relief. The impact properties measured at any location in the first article forging(s) at a depth below the heat treated surface equivalent to the location of the impact specimens in the prolongation/test block shall meet the requirements of [Table E-3](#) (see E.4.3.1.4).

Table E-3. Impact Property Requirements. 1/

Nominal Cross-Section 1/ inches (millimeters)	Test Temperatures °F (°C) ±3 °F (±2 °C)	Minimum Average Charpy Test 2/ ft-lb (J)		Minimum Average Dynamic Tear Test 3/ ft-lb (J)		Minimum Shear Fracture 2/ percent
		HY-80	HY-100	HY-80	HY-100	
½ through 8 (13 through 203) 4/, 10/	-120 (-84)	50 (68)				50
	0 (-18)	60 (81)				90
Over 8 (Over 203) 9/, 10/	-120 (-84)	30 (41)				40
	0 (-18)	60 (81)				90
½ through 6 (13 through 152) 4/, 10/	-120 (-84)		50 (68) 5/			50
	0 (-18)		60 (81)			90
Over 6 (Over 152) 9/, 10/	-120 (-84)		35 (47)			40
	0 (-18)		60 (81)			90
Over 5/8 through 8 (Over 13 through 203) 6/				450 (610)		
Over 8 (over 203) 7/, 8/, 9/				400 (542)		
Over 5/8 through 6 (Over 13 through 152) 6/					500 (678)	
Over 6 (Over 152) 7/, 8/, 9/					450 (610)	

Table E-3. Impact Property Requirements - Continued. 1/

NOTES:

1/ Sampling and location of test specimens shall be as specified in E.4.3.1.4 and E.4.4.3. T is defined in E.3.1.3.

2/ Average of three specimens. No single test value shall be below the minimum average by more than 5 ft-lbs (7 joules). Percent shear fracture measurement is required on each Charpy V-notch specimen. No individual result shall be lower than the minimum.

3/ Average of two specimens at minus 40±3 °F (minus 40±2 °C). Unless otherwise specified (see E.6.2), dynamic tear testing is not required for material less than 5/8 inch (16 mm) in maximum cross-section.

4/ Unless otherwise specified (see E.6.2), Charpy testing is not required for material less than 1/2 inch (13 mm) in maximum cross-section.

5/ When longitudinal impact specimens are provided, the average value shall be 65 foot-pounds (88 joules) minimum at minus 120 °F (minus 84 °C).

6/ No individual value shall be more than 25 ft-lbs (34 J) below the specified minimum average.

7/ No individual value shall be more than 50 ft-lbs (68 J) below the specified minimum average.

8/ For HY-80 forgings over 15 inches (381 mm) thick, the minimum average DT energy shall be 400 ft-lbs (542 J) unless specified otherwise by the purchaser (see E.6.2). For HY-100 forgings over 15 inches (381 mm) thick, the minimum average DT energy shall be 450 ft-lbs (610 J) unless specified otherwise by the purchaser (see E.6.2).

9/ Unless otherwise specified (see E.6.2), for HY-80 forgings over 10 inches (254 mm) thick and HY-100 forgings over 8 inches (203 mm) thick, the second set of specimens, taken such that one surface of the specimen is at a depth of T/2 below the surface, shall have a minimum average DT energy at minus 40 °F (minus 40 °C) not lower than 300 ft-lbs (407 J) for HY-80 and not lower than 350 ft-lbs (474 J) for HY-100.

10/ When specified by the purchaser, an additional set of three Charpy V-notch specimens shall be taken at a location 1 inch (25 mm) below any as quenched surface and tested at minus 120 °F (minus 84 °C). The minimum average impact energy shall not be lower than 59 ft-lbs (80 J).

E.3.5 Explosion Testing. Explosion testing is required as part of first article testing and is not required for conformance testing. Two explosion crack starter tests are required for first article testing. Both specimens shall conform to the crack starter configuration requirements on [Figure L-8](#) and meet the explosion crack starter requirements in Appendix L. When explosion bulge type testing is specified (see E.6.2), testing shall be in accordance with Appendix L and explosion bulge test shots shall continue until a minimum reduction in thickness of 16 percent for HY-80 or 14 percent for HY-100 is obtained on one or both sides.

E.3.6 Heat Treatment. The Contractor shall determine the detailed procedure that will produce forgings that will meet the mechanical requirements specified herein, with the following restrictions:

- a. The forgings shall be quenched and tempered. The quench and temper shall be preceded by a homogenize, normalize, or anneal heat treatment. When necessary to achieve mechanical properties, double tempering is permitted and the restrictions for single tempering shall apply to double tempering. The tempering temperature shall be not less than 1175 °F (635 °C) for Grade HY-80 and 1125 °F (607 °C) for Grade HY-100. The tempering temperature for HY-80 and HY-100 at any location on the forgings shall not exceed 1265 °F (685 °C). When specified by the purchaser (see E.6.2), the tempering temperature for HY-80 and HY-100 shall not exceed 1247 °F (675 °C). After tempering and stress relief heat treatments, all forgings, including test block(s), that constitute the furnace load shall be removed from the furnace and rapidly cooled by water, aqueous polymer, or forced air quenching at the same time (i.e., the same quench load). The use of more than one quench load for tempering and stress relief heat treatment of a single furnace load of forgings is prohibited. When test blocks are used instead of prolongations, the test blocks shall accompany the forgings they represent in all heat treatments and shall be quenched at the same time (i.e., in the same quench load) as the forging(s) that they represent. All forgings shall be arranged such that, as far as possible, they and the test block(s) receive equal and uniform exposure to the quench media.
- b. Unless otherwise specified (see E.6.2), the tempering and stress relief heat-treat cycles shall have the following contact thermocouples attached to the forging(s) and the prolongation/test blocks during the cycles: one contact thermocouple shall be placed on thickest and thinnest sections of the forgings in the furnace load, and on the forging or prolongation/test block surface closest to a furnace burner. In addition, one contact thermocouple shall be placed on each prolongation/test block representing the furnace load. Upon reaching the target final tempering and stress

relief heat treatment temperature, the temperatures of all forging thermocouples shall fall within ± 25 °F (± 14 °C) degrees of the prolongation/test block temperature.

- c. When necessary for distortion control, Grade HY-80 forgings may be stress relieved after final tempering. The stress relief temperature for Grade HY-80 forgings shall be 1125 °F (607 °C). Stress relief of Grade HY-100 is not permitted unless approved by NAVSEA on a case basis. When permitted by NAVSEA, the stress relief temperature for Grade HY-100 forgings shall be 1075 °F (579 °C).
- d. For all heat treatment operations, forgings shall be positioned and supported in such a manner to prevent shifting or falling from their initial set positions during the heat treatment process. In addition, during tempering and stress relief, forgings shall be positioned in the furnace so that, in a direct-fired furnace, burner flames and hot gases from these flames cannot impinge upon forging surfaces and result in heating the forgings above the maximum allowable tempering temperature. As a minimum, the forgings shall be supported in the furnace by a grating/floor structure, suitable furnace blocks, or similar structure that ensures that the forgings cannot fall or shift outside of the furnace working zone and be exposed to burner flames or hot gases. Attention shall be given to ensure that the structure supporting the grating/floor in the furnace, such as pylons, sawhorses, racks, or the furnace blocks, will not deflect flames and hot gases onto forging surfaces and that these supports are in a permanent/semi-permanent position.
- e. In addition to the requirements of 3.5 for batch-type furnaces, the heat treatment record shall also include digital photographs and sketches providing sufficient accuracy to recreate positions and orientations of the forgings in the furnace at future dates. The sketches shall identify every part in the load uniquely according to a vendor's internal tracking methodology. The photographs in the heat treatment record shall be of the furnace car forging-load immediately prior to entering and immediately after leaving the furnace for the tempering cycle(s) and stress relief. The sketches in the heat treatment record shall include placement of forgings, forging support structure (i.e., pylons, saw horses, racks, etc.) on the furnace car, placement of the burners in the furnace, and the distances and orientations of the forging and support structure with respect to the burners. The verification of inspection record shall validate the forging was loaded in accordance with the sketches and photographs in the heat treatment record. The verification of inspection record shall also validate the sketches and photographs are consistent with all support structure and forging positions during the tempering heat treatment.
- f. The quench tank facility used to accomplish the austenitizing heat treatment shall be of a sufficient capacity and design to provide multi-directional (from at least three directions or other equivalent design based on data and on results of first article testing) water flow for effective quenching of the largest forgings to be heat treated. The effectiveness of the quench tank facility in terms of capacity and water flow shall be demonstrated during first article testing where both the largest size (i.e., thickness and complexity) forging and the accompanying test blocks are demonstrated to meet the minimum mechanical property requirements. The maximum quench tank water temperature at the initiation of the quenching operation shall not exceed 80 °F (27 °C). A process shall be put in place to maintain the effectiveness (e.g., flow rate and water capacity) of the quench tank similar to that used during the first article qualification.

E.3.6.1 Simulated Stress Relief. When a simulated stress relief is specified (see E.6.2), a prolongation/test block as specified in E.4.3.1.2 shall be subjected to the stress relief thermal cycle based on the tempering temperature of the material (see E.3.6), shall be tested for mechanical and impact properties in accordance with E.4.4, and shall meet the requirements specified in E.3.3 and E.3.4. The stress relief thermal cycles (including cooling rates) shall be specified (see E.6.2).

E.3.6.1.1 Verification of Properties. When specified (see E.6.2), a representative sample, in the form of a prolongation or test block, as specified in E.3.6.1, shall be forwarded with the material to verify properties, after the proposed stress relief, as specified in the applicable fabrication document.

E.3.6.2 Prolongations or Test Blocks. When integral prolongations or forged test blocks are specified for possible stress relief operations by the contracting activity (see E.6.2), they shall be heat treated with the actual forgings and shall represent the maximum cross-section of the thickest heat treated component section.

E.3.7 Forging Sketches. A forging sketch shall be prepared for purchaser approval that shows the minimum reduction ratio that is to be achieved in each portion of the forging and the location of test specimens for determining mechanical properties. Location of specimens for mechanical properties as shown on [Figure E-1](#), [Figure E-2](#), and [Figure E-3](#) shall be considered when preparing the forging sketch for symmetrical forgings. All prolongations shall be included as part of the forging sketch.

E.3.8 Dimensions and Tolerances. Each forging shall conform to the dimensions and tolerances specified on the applicable drawing, contract, or order (see E.6.2). Heat treated forgings shall be furnished that can be machined to the

T9074-BD-GIB-010/0300 Rev 2

finished dimensions within the tolerance given without further straightening. Layout points, when required, shall be shown as such on the applicable drawings, and shall be incorporated in the forgings.

E.3.9 Soundness. Forgings and forging test blocks shall be of uniform quality and condition, and shall be free of defects harmful to their intended use, as determined by visual examination and the applicable nondestructive tests.

E.3.9.1 Surface Soundness. Forgings shall be subjected to a magnetic particle test in accordance with E.4.5.3 and shall be free of relevant linear indications greater than 1/8 inch (3 mm) in length.

E.3.9.1.1 Repair of Surface Defects. Defects may be removed by chipping, grinding, or other mechanical means, provided the width of the involved area is three times its depth and gradually tapers into the defects, and the design dimensions are not violated. Heat shall not be applied to remove defects after heat treatment or stress relief.

E.3.9.1.2 Repair of Surface Defects by Welding. Weld repair shall not be used unless specifically approved on a case basis by the Command or Agency concerned.

E.3.9.2 Internal Soundness. Unless otherwise specified (see E.6.2), each forging shall be ultrasonically tested in accordance with E.4.5.2 and shall meet the acceptance criteria specified in E.3.9.2.1.

E.3.9.2.1 Ultrasonic Soundness Acceptance Criteria. Any discontinuity whose reflection produces a signal equal to or greater than the response from the reference calibration standard set forth in T9074-AS-GIB-010/271, or causes complete loss of back reflection between parallel surfaces, shall be cause for rejection of the forging. For applications requiring other acceptance criteria, the criteria shall be as specified (see E.6.2).

E.3.9.3 Macroscopic Examination. After final heat treatment, forgings shall be demonstrated to be free from cast dendritic structure based on macroscopic examination at 5X magnification per ASTM E381.

E.3.10 Identification Marking. Forgings including prolongations or forging test blocks shall be identified with the Contractor's name or trademark and a serial number that will positively identify the forging part number, melt from which they were poured, and the lot with which they were heat treated. Markings shall be placed in a location such that they will not be machined off in finishing, and in an area that is stressed least in service.

E.4 VERIFICATION.

E.4.1 Responsibility for Inspection. See 4.1.

E.4.2 Classification of Inspections. The inspection requirements specified herein are classified as follows:

- a. First article inspection (see E.4.3).
- b. Conformance inspection (see E.4.4).

E.4.3 First Article Inspection. First article inspection shall consist of testing the samples specified in E.4.3.1 in accordance with the procedures specified in E.4.5 and [Table E-4](#) (see E.6.3, 4.3, and Appendix L). First article inspection, including explosion testing per Appendix L, is required for forging sources melting their own forging stock or using stock from an unapproved source. Explosion testing is not required as part of first article approval for a forger or reforger using an approved melt source. Any approved melt source may be used after the first article approval of a forger or reforger. Unless otherwise specifically approved by NAVSEA, production articles may not use a reduction ratio less than that approved by first article testing for the thicker of the two required first article forgings.

Table E-4. First Article and Conformance Inspection Requirements.

Examination and Tests	Requirement	Test Method	First Article	Conformance
Chemical analysis	E.3.2	4.5.1 and E.4.5.1	X	X
Tensile properties	E.3.3	4.5.2	X	X
Explosion	E.3.5	4.5.5	X	---
Impact Properties				
Charpy V-notch	E.3.4	4.5.3	X	X
Dynamic tear	E.3.4	4.5.4	X	X
Examination				
Surface quality	E.3.9.1	E.4.5.3	X	X
Dimensional	E.3.8	E.6.2	X	X
Internal soundness	E.3.9.2	E.4.5.2	X	X
Macroscopic	E.3.9.3	E.4.3.1.4.6 and E.4.4.6	X	X

E.4.3.1 First Article Samples. First article samples shall consist of material from one heat sufficient to obtain measurements of the mechanical properties of the material and its weldment. In addition, weldments shall be subjected to the explosion test as specified in Appendix L. The test shall be conducted under Government direction to evaluate weldment performance in shock applications.

E.4.3.1.1 Forgings. First article samples shall be forgings representative of the largest size (i.e., largest section thickness) to be forged of HY-80 or HY-100 at the facility, from one lot (see E.4.4.1), and approved by NAVSEA. A minimum of two HY-80 or HY-100 forgings of the largest size and sufficient complexity to demonstrate the capability to provide forgings with acceptable chemistry and mechanical properties throughout the forging section shall be produced for first article inspection. Unless otherwise specified (see E.6.2), HY-80 and HY-100 shall be tested separately. For each of the two required first articles, material shall be forged or rolled to the minimum reduction deemed acceptable by the producer to obtain material which meets all of the requirements herein. This minimum reduction shall be maintained as a requirement for all future procurements.

E.4.3.1.1.1 First Article Complexity. The forger must produce first article forgings which are representative of the production pieces they intend to produce. The three basic open die forging geometries are described in the first three subparagraphs below. A minimum of two forgings are required for first article qualification and approval. The two forgings may be of a different or of the same configuration. However, at a minimum, the forger shall produce one first article forging for each type of configuration it intends to qualify to produce. If only one type of configuration will be qualified, then two forgings of that type must be produced for first article. The forger must determine the type of geometry it has the capability for and intends to produce, and shall qualify to the maximum thickness it intends to produce for each configuration type. For each configuration, the material shall be forged to the minimum reduction deemed acceptable by the producer to obtain material which meets all of the requirements herein. This minimum reduction shall be the minimum approved for production articles and maintained as a requirement for all future forgings to this specification.

E.4.3.1.1.1.1 Solid Shapes. Solid shapes are defined as any symmetrical rectangular or circular shape without any penetrations produced by forging operations. Such forgings must be symmetrical at the completion of the forging and heat treatment operations. The shape may have different dimensions or diameters along its length.

E.4.3.1.1.1.2 Hollow Forgings. Hollow forgings are defined as any forging which is produced as a result of punching the centerline of an ingot out of the forging during a forging operation. Such forgings must be symmetrical at the completion of the forging and heat treatment operations. The hollow forging may have different diameters or other dimensions along its length.

E.4.3.1.1.1.3 Ring Forgings. Ring forgings are defined as any forging processed on a ring roller or similar manufacturing technique at any point during its manufacture and having an axisymmetric ring shape at the completion of the forging and heat treatment operations. Ring forgings typically have shorter lengths than hollow forgings.

E.4.3.1.1.1.4 Other, More Complex Designs. More complex forged items are defined as those that are outside of the above three geometries (forged to shape or machined to shape prior to heat treatment) or present difficulties with ensuring an adequate heat treatment for the entire forging due to forging configuration. When such forgings are submitted for bid and/or ordered, the forger shall contact the procuring agent for guidance on these types of complex forgings. The procuring agent

T9074-BD-GIB-010/0300 Rev 2

may require prototype manufacturing and testing prior to production and/or additional conformance testing. The procuring agent may also specify (see 6.2) such prototype testing and/or additional conformance testing in the bid and/or order. In all cases, the requirements of this specification shall be met.

E.4.3.1.2 Test Prolongations. Prolongations and, if used, separately forged blocks sufficient to meet the testing requirements of this specification shall be provided. Prolongations shall be part of the forgings until after heat treatment.

E.4.3.1.2.1 Prolongation or Separately Forged Test Block Sizes. The size of the prolongation or separately forged test blocks shall be equivalent to the largest cross-section of the forging.

E.4.3.1.3 Explosion Test Specimens. Twelve unwelded plate forgings 2 by 16 by 55 inches (51 by 406 by 1397 mm) shall be provided for explosion testing as specified in E.3.5 and 4.5.5.

E.4.3.1.4 Test Specimen Location. Test specimens for first article inspection shall be taken from the prolongations and from the first article forgings. Samples shall be taken from the first article forgings at the center and from the opposite extremes (the locations between which the longest straight line can be drawn) and as specified in E.4.4.3. Samples from prolongations or, if used, separately forged test blocks shall be taken as specified in E.4.4.3.1. The test specimen locations in accordance with the requirements below shall be submitted in the forging sketch for approval.

- a. For impact specimens, the locations specified below in E.4.3.1.4.b to E.4.3.1.4.g apply to one longitudinal side of the specimen. For tensile specimens, the locations below in E.4.3.1.4.b to E.4.3.1.4.f apply to the midpoint of the specimen.
- b. All test specimens shall be taken at a depth of $T/2$ from any heat treated surface for T less than or equal to 8 inches (203 mm) (for HY-80) and 6 inches (152 mm) (for HY-100) where T is defined as the as-quenched thickness (minimum dimension) of the heaviest cross-section of the forging with the exception that the depth from the second nearest heat treated surface shall be $W/2$ or T , whichever is less, with W as defined in E.4.4.3.2.2.
- c. For HY-80 forgings with T greater than 8 inches (203 mm) and less than or equal to 16 inches (406 mm), the specimen shall be taken at depth of no closer than 4 inches (102 mm) from any heat treated surface, except that the depth from the second nearest heat treated surface shall be $W/4$ as specified in E.4.4.3.2.2 or 4 inches, whichever is greater.
- d. For HY-100 forgings with T greater than 6 inches (152 mm) and less than or equal to 12 inches (305 mm), specimens shall be taken at a depth of 3 inches (76 mm) from any heat treated surface except that the depth from the second nearest heat treated surface shall be $W/4$ as specified in E.4.4.3.2.2 or 3 inches, whichever is greater.
- e. For T greater than 16 inches (406 mm) for HY-80 forgings, specimens shall be taken at a depth no closer than $T/4$ from any heat treated surface, unless otherwise approved by the Command or Agency concerned (see E.6.2) and with the exception that the depth from the second nearest heat treated surface shall be $W/4$ as specified in E.4.4.3.2.2 or T , whichever is less.
- f. For T greater than 12 inches (305 mm) for HY-100 forgings, specimens shall be taken at a depth no closer than $T/4$ from any heat treated surface, unless otherwise approved by the Command or Agency concerned (see E.6.2), and with the exception that the depth from the second nearest heat treated surface shall be $W/4$ as specified in E.4.4.3.2.2 or T whichever is less.
- g. For T greater than 10 inches (254 mm) (in HY-80 forgings) and T greater than 8 inches (203 mm) (in HY-100 forgings), a second set of specimens shall be taken such that one surface of the specimen is at a depth of $T/2$ below any heat treated surface except that the depth from the second nearest surface shall be $W/2$ with W as defined in E.4.4.3.2.2 or T , whichever is less. On solid forgings which are round or square in cross-section, the specimens may be stacked together near the center in a tight circular arrangement or grouped together on circular or square configurations, respectively.

E.4.3.1.4.1 Chemical Analysis. Chemical analysis shall be determined at each of the locations specified in E.4.3.1.4 and from a suitably prepared heat analysis sample and shall meet the requirements in E.3.2.

E.4.3.1.4.2 Tensile Test. A tensile test specimen shall be taken at the locations as specified in E.4.3.1.4 and shall meet the requirements in E.3.3.

E.4.3.1.4.3 Dynamic Tear. A set of two transverse dynamic tear test specimens shall be taken from the first article forging and the prolongations at each of the locations specified in E.4.3.1.4. These specimens shall be tested at minus 40 °F (minus 40 °C) and shall meet the requirements in E.3.4, [Table E-3](#).

E.4.3.1.4.4 Charpy V-Notch. A set of three Charpy impact specimens shall be tested from each of the locations specified in E.4.3.1.4 at each temperature. These specimens shall be tested at 0 °F (minus 18 °C) and minus 120 °F (minus 84 °C) and shall meet the requirements in E.3.4.

E.4.3.1.4.5 Charpy Impact Transition Curves. Charpy V-notch transition curves (longitudinal and transverse), with a minimum of five temperatures from minus 120 °F (minus 84 °C) to room temperature, shall be obtained from a prolongation to the first article forging at the locations specified in E.4.3.1.4. A minimum of three specimens for each temperature is required, and all individual energy and percent shear values shall be reported.

E.4.3.1.4.6 Macroscopic Examination. After final heat treatment, a full thickness cross-section shall be removed from each first article forging and the associated prolongation(s). Each cross-section shall be subjected to macroscopic examination and shall meet the requirements in E.3.9.3.

E.4.3.2 First Article Inspection Report. See 3.1.

E.4.4 Conformance Inspection. Conformance inspection (i.e., inspections of production lots) shall be as specified in E.4.4.1 through E.4.4.7 and in [Table E-4](#).

E.4.4.1 Lot Size. The lot size shall be as specified in E.4.4.1.1 through E.4.4.1.3.

E.4.4.1.1 Lot Size for Tension and Impact Tests. The lot size for tension and impact tests shall be as follows:

- a. Forgings with an as-heat-treated weight of less than 1,000 pounds (454 kg): All forgings of one design, produced from the same heat or melt, and heat treated in the same furnace charges shall constitute a lot.
- b. Forgings with an as-heat-treated weight of 1,000 pounds (454 kg) or more: Each forging shall constitute a lot.

E.4.4.1.2 Lot Size for Examination and Inspection. Each forging shall be considered a lot.

E.4.4.1.3 Lot Size for Chemical Analysis. See 4.4.1.1.

E.4.4.2 Sampling for Chemical Analysis. The test sample shall be taken during the pouring of the heat at a time that best represents the composition of the cast. Test samples shall also be taken from one of the broken tensile specimens from each prolongation/test block forging (see E.4.4.3). In the case where heat analysis samples are lost or inadequate, or when it is evident that the sample does not truly represent the heat, representative samples may be taken from the product when approved by NAVSEA. The analysis shall meet the specified limits for heat analysis. Product analysis limits shall only apply to the analysis performed on broken tensile specimens. This analysis shall not be used as a substitute for the heat analysis.

E.4.4.3 Sampling for Mechanical Properties. Sampling for mechanical properties shall be as follows:

- a. From each lot as specified in E.4.4.1.1.a, two of the forgings shall be tested for mechanical properties.
- b. From each lot as specified in E.4.4.1.1.b, each forging shall be tested for mechanical properties.

E.4.4.3.1 Location, Orientation, and Number of Specimens. The location in the forging, the orientation, and the number of specimens to be tested shall be in accordance with the approved forging drawing and as specified herein. From each location within a forging, one longitudinal and one transverse tensile, three transverse impact, and two dynamic tear impact specimens for each test temperature shall be taken from each forging tested. Forgings with a length of 80 inches (2032 mm) or less (excluding test metal) shall have the tensile and impact tests removed from one end of the forging. When the length of the forging, excluding test metal, exceeds 80 inches (2032 mm), the testing as designated for forgings less than 80 inches (2032 mm) in length shall be carried out at each end of the forging.

E.4.4.3.2 Location of Mechanical Test Specimens. Integral prolongations of full section thickness shall be provided whenever feasible. If integral prolongations are not feasible, then a production forging or a forged block of representative section size, made from the same heat and subjected to the same type and degree of hot working as the forging it represents, may be used for test material. When prolongations are used but it is impractical to provide enough material to meet the required distance between test material and quenched surfaces, then metal buffers may be used to meet the distance requirement for quenching. The buffer material may be any weldable carbon or low-alloy steel and shall be joined to the forging with a partial-penetration weld that completely seals the buffered surface.

E.4.4.3.2.1 Distance of Tensile and Impact Specimens from the Nearest Heat Treated Surface. Locations as in E.4.3.1.4.a through E.4.3.1.4.f shall apply. Unless otherwise specified (see E.6.2), E.4.3.1.4.g shall also apply. These locations are illustrated on [Figure E-1](#), [Figure E-2](#), and [Figure E-3](#).

E.4.4.3.2.2 Distance of Tensile and Impact Specimens from the Second Nearest Heat Treated Surface. [Not applicable to ring or hollow cylindrical forgings (see E.4.4.3.2.1)]. “W” is defined as the as-quenched width (second smallest

T9074-BD-GIB-010/0300 Rev 2

dimension) of the heaviest cross-section of the forging. Locations from W, as in E.4.3.1.4.a through E.4.3.1.4.f, shall apply. Unless otherwise specified (see E.6.2), E.4.3.1.4.g shall also apply. These locations are illustrated on [Figure E-1](#), [Figure E-2](#), and [Figure E-3](#).

E.4.4.3.2.3 Distance of Tensile and Impact Specimens from the End of the Forging. Locations from the end, as in E.4.3.1.4.a through E.4.3.1.4.f, shall apply. Unless otherwise specified (see E.6.2), E.4.3.1.4.g shall also apply. These locations are illustrated on [Figure E-1](#), [Figure E-2](#), and [Figure E-3](#).

E.4.4.3.2.4 Sampling for Mechanical Properties Following Simulated Stress Relief. When specified (see E.3.6.1), sample material (see E.4.4.3) shall be subjected to simulated stress relief operations after quenching and tempering, but prior to testing for conformance to the mechanical property requirements specified in E.3.3 and E.3.4. The sample material shall not be removed from the material prior to quenching and tempering. The total time at temperature and cooling rate for the simulated stress relief operations shall be as specified (see E.3.6.1). The cooling rate, and the maximum and minimum time at temperature used on the sample material shall be incorporated in the test certification along with the destructive and nondestructive test results.

E.4.4.3.2.5 Multiple Forgings. When forgings are made and heat treated in multiples, such as when two or more individual pieces are machined from a single heat treated forging, specimens representing the composite forging shall be required. The composite forging's weight and size shall govern the lot definition and scheme of testing.

E.4.4.3.3. Orientation of Test Specimens.

E.4.4.3.3.1 Orientation of Longitudinal Tensile Specimens. Unless otherwise shown on the forging sketch (see E.3.7), the major axis of the longitudinal tensile specimen shall be oriented as follows:

- a. In a tangential direction for upset disc, hollow (pierced and expanded) cylindrical and ring forgings; that is, perpendicular to both radius and central axis of the forging. If the wall thickness or radius of the hollow cylindrical forging is too small to permit tangential orientation of the longitudinal specimen axis, the axis of the specimens may be aligned perpendicular to the radius of and parallel to the central axis of the cylindrical forging.
- b. Parallel to the central axis of the cylindrical forging for extruded or drawn hollow cylinders, and for extruded or drawn solid cylinders subsequently bored out where the principal direction of metal working during forging is parallel to the central axis of the cylindrical forging.
- c. Parallel to the principal direction in which forged metal was worked for all other forging configurations as shown on the forging sketch.

E.4.4.3.3.2 Orientation of Transverse Tensile Specimens. Unless otherwise shown on the forging sketch, the major axis of the transverse specimen shall be oriented as follows:

- a. Perpendicular to the radius of and parallel to the central axis of the forging for upset disc, hollow (pierced and expanded) cylindrical and ring forgings. No transverse specimen is required when longitudinal specimen is oriented in longitudinal direction as specified in E.4.4.3.3.1.a.
- b. Perpendicular to both the radius and central axis of the forging for extruded or drawn cylinders (hollow or solid); that is, in the tangential direction. When the wall thickness or radius of the hollow cylindrical forging is too small to permit the tangentially oriented specimen, no transverse specimen is required.
- c. Perpendicular to the principal direction in which the forged metal was worked for all other forging types or configurations as shown on the forging sketch.

E.4.4.3.3.3 Orientation of Impact Specimens. Orientation of impact specimens shall be as follows:

- a. Impact specimens shall be transverse to the principal axis or length of the forging with the notch perpendicular to the nearest forged surface.
- b. When longitudinal impact specimens are provided, the specimen's longitudinal axis shall be parallel to the principal axis of length of the forged section. The axis of the notch shall be perpendicular to the longitudinal axis and perpendicular to the nearest quenched and tempered surface.
- c. When impact specimens as defined in E.4.4.3.3.3.a and E.4.4.3.3.3.b above cannot be obtained, longitudinal impact specimens shall be provided. One of the specimen's longitudinal axis sides shall be located at the center of the cross-section.

E.4.4.4 Sampling for Forging Soundness (Internal). Unless otherwise specified (see E.6.2), each forging shall be ultrasonically tested at the latest point in processing which will produce a meaningful test in determining conformance to the soundness requirements specified in E.3.9.2.1.

E.4.4.5 Sampling for Forging Soundness (External). Unless otherwise specified (see E.6.2), each forging shall be subject to magnetic particle inspection. Each forging shall be in the finished condition ready for shipment as specified (see E.4.5.3).

E.4.4.6 Macroscopic Examination. Unless approved otherwise by NAVSEA based on data presented at first article approval, a full thickness cross-section shall be removed from each prolongation. Each cross-section shall be subjected to macroscopic examination and shall meet the requirements in E.3.9.3.

E.4.4.7 Visual and Dimensional Examination. Each forging shall be examined for conformance to the specified dimensions and soundness (see E.3.8 through E.3.9.2).

E.4.5 Test Procedures. See [Table E-4](#) and 4.5.

E.4.5.1 Chemical or Spectrographic Analysis. If any analysis fails to conform to E.3.2, the requirements in 4.6 apply. When both a heat and product analysis are determined, the product analysis shall be used to determine acceptance or rejection.

E.4.5.2 Ultrasonic Test. Unless alternate ultrasonic soundness inspection requirements are specified (see E.6.2), ultrasonic testing shall be performed in accordance with T9074-AS-GIB-010/271, except that bar, rod, and bored rounds shall additionally be examined from both end faces. For end scans, calibration shall be the same as was used for the part thickness or diameter, but increase the range to include the part length.

E.4.5.3 Magnetic Particle Inspection. Unless otherwise specified (see E.6.2), 100 percent of each forging's surface shall be magnetic particle tested in the final heat treated condition in accordance with T9074-AS-GIB-010/271. Bored surfaces shall be examined for three times the bore diameter from each end only. When magnetic particle testing is injurious to a machined surface, dye penetrant testing in accordance with T9074-AS-GIB-010/271 is a satisfactory substitute.

E.5 PACKAGING

See Chapter 5.

E.6 NOTES

E.6.1 Intended Use. Grade HY-80 and Grade HY-100 alloy steel forgings are intended primarily for use in critical structural applications where a notch-tough, high-strength material is required. The use of this steel in fabricated structure or equipment entails much more than a material specification and caution is advised in the areas of welding, fabrication, and nondestructive testing.

E.6.2 Acquisition Requirements. Acquisition documents must specify the following:

- a. Title, number, and date of this specification.
- b. Grade required (see E.1.2).
- c. If chemical product analysis tolerances are to be different than those specified in ASTM A788 (see E.3.2).
- d. When the carbon equivalent of the heat shall not exceed 0.72 percent and specifying the carbon equivalent formula to be used to determine the carbon equivalent value (see [Table E-1](#), note 4).
- e. Tensile property requirements for the T/2 specimens in over 8-inch (203-mm) thick HY-100 forgings (see [Table E-2](#), note 2).
- f. If dynamic tear testing is required for material less than $\frac{5}{8}$ inch (16 mm) in maximum cross-section (see [Table E-3](#), note 3).
- g. If Charpy impact is required for material less than $\frac{1}{2}$ inch (13 mm) in maximum cross-section (see [Table E-3](#), note 4).
- h. Minimum average DT values for HY-80 and HY-100 forgings over 15 inches (381 mm) thick (see [Table E-3](#), note 8).
- i. Minimum average DT values for the second set of specimens taken at T/2 for specimens over 10 inches (254 mm) thick (HY-80) or 8 inches (203 mm) thick (HY-100) (see [Table E-3](#), note 9).
- j. When an additional set of Charpy impact testing is required at 1 inch (25 mm) from any quenched surface (see [Table E-3](#), note 10).
- k. If explosion bulge type testing is required (see E.3.5).

T9074-BD-GIB-010/0300 Rev 2

- l. When the tempering temperature for HY-80 and HY-100 shall not exceed 1247 °F (675 °C) (see E.3.6.a).
- m. If thermocouples are required in alternate locations (see E.3.6.b).
- n. When a simulated stress relief sample is required; the number of thermal cycles, the heating and cooling rates, and the time at temperature (see E.3.6.1 and E.4.4.3.2.4).
- o. When a representative sample is required to be forwarded with the material to verify properties (see E.3.6.1.1).
- p. When integral prolongations or forged test blocks are required for stress relief operations (see E.3.6.2).
- q. Dimensions and tolerances (see E.3.8).
- r. If each forging is not to be ultrasonically tested (see E.3.9.2 and E.4.4.4).
- s. If ultrasonic procedures and/or acceptance criteria are different than as specified (see E.3.9.2.1 and E.4.5.2).
- t. If HY-80 and HY-100 forgings are to be first article tested together (see E.4.3.1.1).
- u. If test specimen location in first article forgings is to be other than T/4 inches (see E.4.3.1.4.f).
- v. When tensile and impact specimens at T/2 are not required (see E.4.4.3.2.1 and E.4.4.3.2.4).
- w. If macroscopic examination is not required (see E.4.4.6).
- x. If magnetic particle testing is other than as specified (see E.4.5.3).
- y. When HY-100 has passed first article testing, whether explosion testing of HY-80 is required (see E.6.3.1).

E.6.3 First Article. See 6.3.

E.6.3.1 First Article Approval. When HY-100 forged material has met first article test requirements, HY-80 may be reviewed for first article approval by submitting the required first article data exclusive of explosion tests, unless specifically required by the contract or purchase order (see E.6.2).

E.6.4 Receipt Inspection. The forgings should be subject to receipt inspection by the contracting activity to verify conformance to the requirements of this specification. Forgings not conforming to the requirements may be rejected by the contracting activity. The forging manufacturer may verify the results of the contracting activity's receipt inspection. It is the responsibility of the contracting activity to determine the acceptability of the forgings for the intended application.

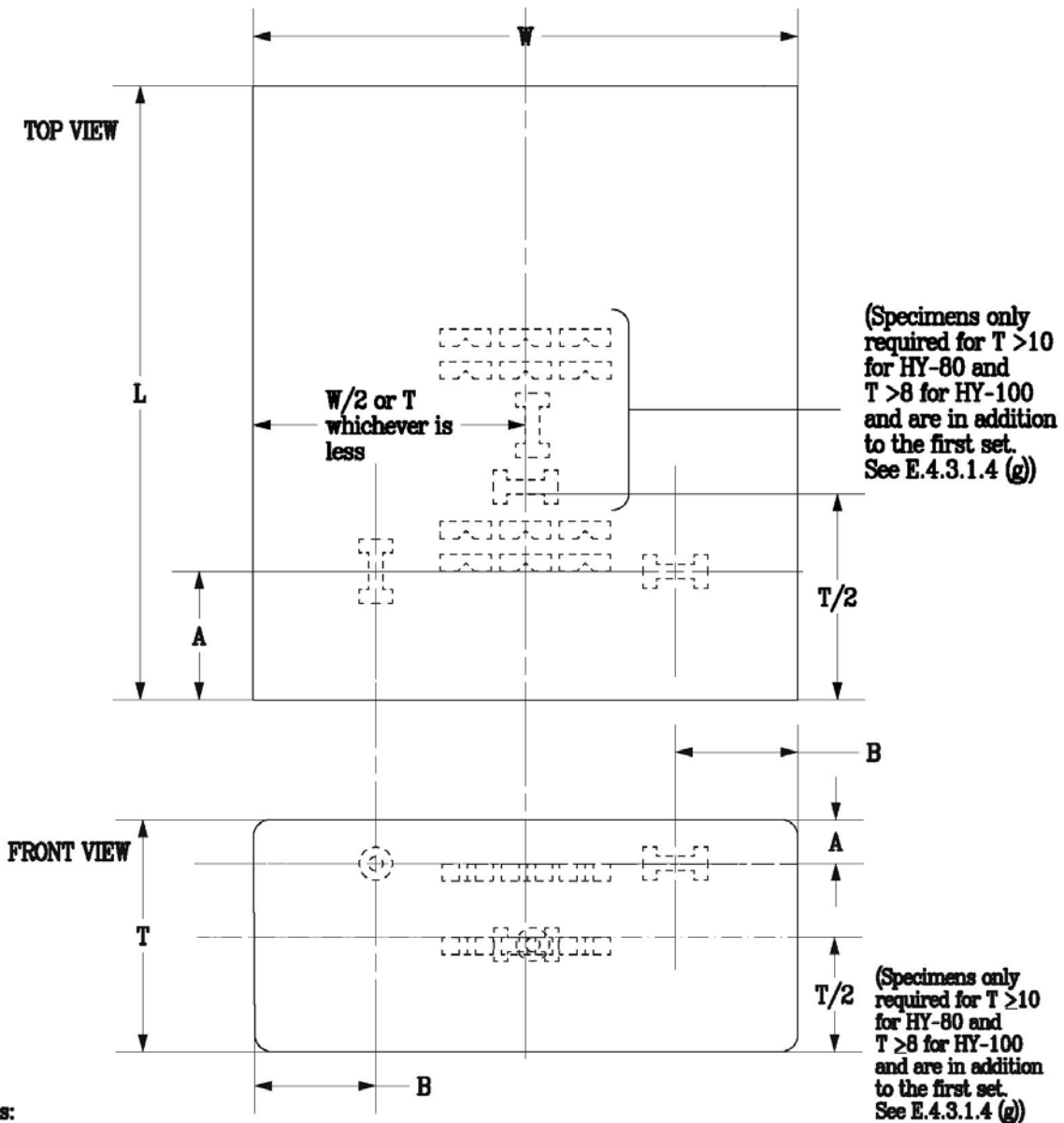

	HY-80		HY-100	
	T Dimension	A	T Dimension	A
1.	$T \leq 6"$	$T/2$	$T \leq 6"$	$T/2$
	$6" < T \leq 16"$	4"	$6" < T \leq 12"$	3"
	$16" < T$	$T/4$	$12" < T$	$T/4$

* Whichever is greater
 ^ Whichever is less

Specimen type	Symbols
Impact	
Tensile	

Figure E-1. Typical Schematic Diagram of Test Specimen Location for a 12-Inch Thick HY-100 Forging “Rectangular-Like” in Cross-Section. (See E.4.3.1.4 for additional specimen locations, and see E.4.4.3.2.)

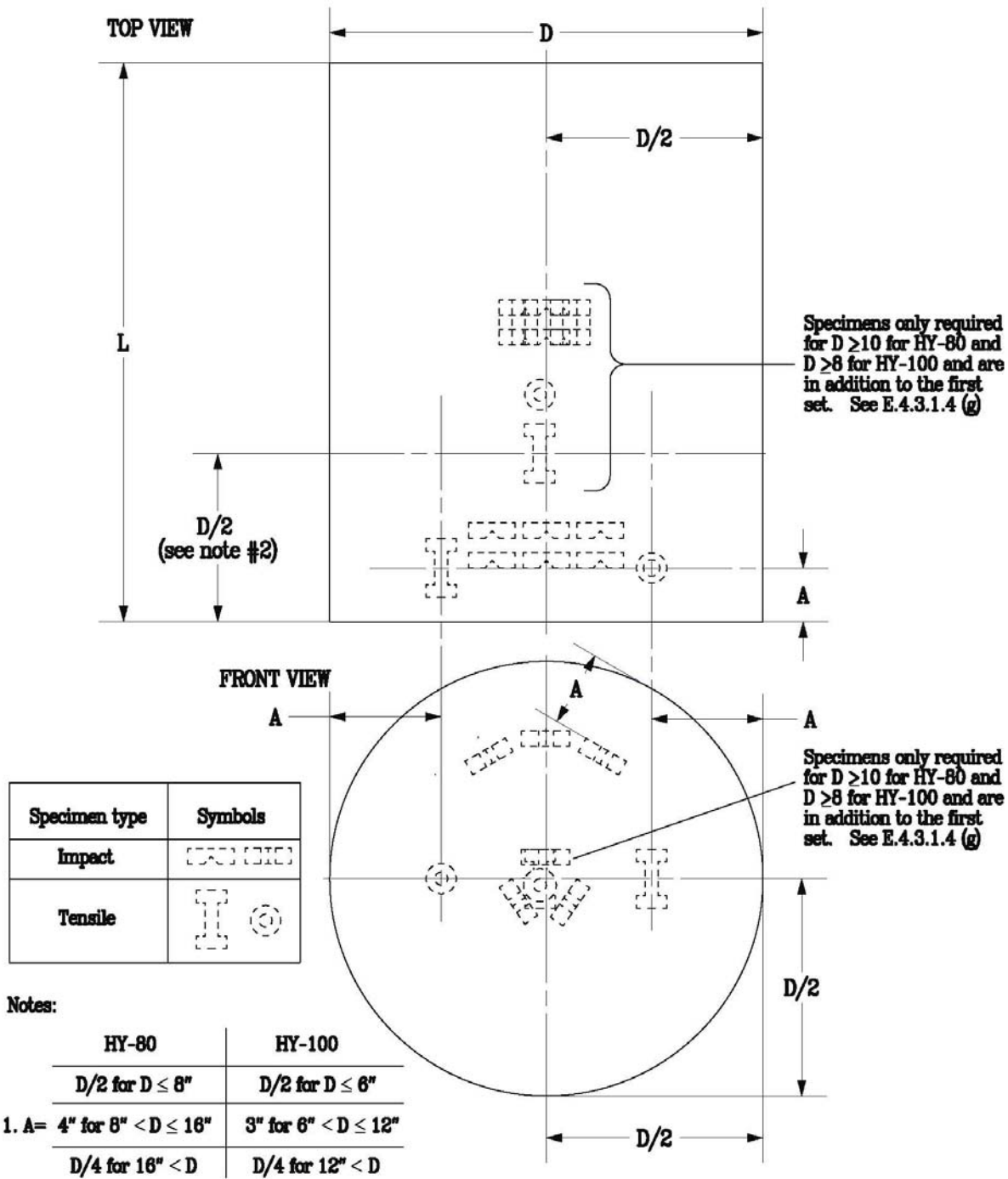
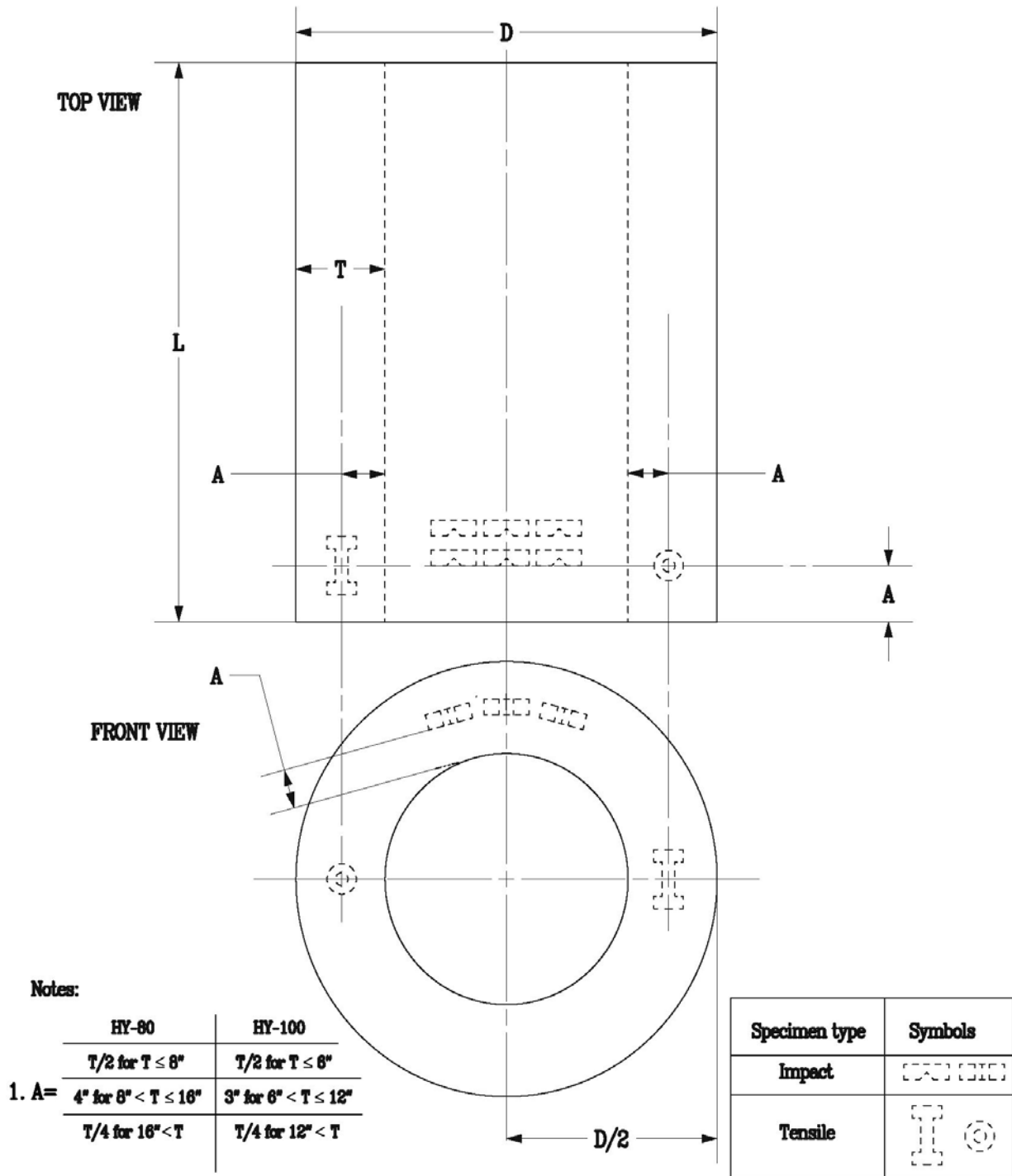

Figure E-2. Typical Schematic Diagram of Test Specimen Location for a 12-Inch Diameter HY-100 Forging of Solid Circular Cross-Section. (See E.4.3.1.4 and E.4.4.3.2 for details on specimen locations.)



2. For T greater than 10 inches and 8 inches in HY-80 and HY-100 forgings, respectively, a second set of specimens shall be taken such that one surface of the specimen is a depth of $T/2$ below the surface. See E.4.3.1.4 (g) and E.4.4.3.2.1 through E.4.4.3.2.3.

3. Specimens notches are parallel to the radial datum, typically $\pm 5^\circ$

Figure E-3. Typical Schematic Diagram of Test Specimen Location for an 8-Inch Thick HY-80 Forging of Bored Circular Cross-Section. (See E.4.3.1.4 and E.4.4.3.2 for details on specimen locations.)

T9074-BD-GIB-010/0300 Rev 2

THIS PAGE INTENTIONALLY LEFT BLANK

APPENDIX F (24371)

STEEL PLATE, STRUCTURAL, HIGH YIELD STRENGTH (HY-130)

F.1 SCOPE.

F.1.1 Scope. This Appendix covers HY-130 steel plate intended primarily for use in submarine hulls and other critical structural applications where a notch-tough, high yield material is required.

F.1.2 Classification. Steel plates covered by this specification shall be of the following types, unless otherwise specified (see F.6.2):

- Type I - Plate for which ultrasonic testing for soundness and thickness is not required.
- Type II - Plate for which ultrasonic testing for soundness and thickness is required. Unless otherwise specified (see F.6.2), each plate over ½ inch (13 mm) in thickness shall be classified as Type II.

F.2 APPLICABLE DOCUMENTS.

See Chapter 2.

F.3 REQUIREMENTS.

F.3.1 Materials. The steel shall be vacuum degassed and very low sulfur, calcium treatment, or other NAVSEA-approved melt practices shall be used for sulfide inclusion shape control in the production of this steel to meet the requirements for mechanical properties transverse to the rolling direction for plate over 1½ inches (38 mm) in thickness.

F.3.2 Ingots and Slabs. Ingots and slabs shall not be weld-repaired.

F.3.3 Heat Treatment.

- a. The plates shall be quenched and tempered. The producer shall determine the detailed procedure for heat treating the plates to meet the mechanical property requirements, with the exception that the austenitizing temperature shall be specified by the mill and shall not exceed 1675 °F, and the tempering temperature shall be not less than 1000 °F.
- b. For all heat treatment operations, plates shall be positioned and supported in such a manner as to prevent shifting or falling from their initial set positions during the heat treatment process. In addition, during tempering, plates shall be positioned in the furnace so that, in a direct-fired furnace, burner flames and hot gases from these flames cannot impinge upon plate surfaces and result in heating the plates above the maximum allowable tempering temperature. As a minimum, the plates shall be supported in the furnace in a manner that ensures that the plates cannot fall or shift outside of the furnace working zone and be exposed to burner flames or hot gases. Attention shall be given to ensure that the structure supporting the plate in the furnace, such as pylons, sawhorses, and racks, will not deflect flames and hot gases onto plate surfaces.
- c. In addition to the requirements of 3.5 for batch-type furnaces, the heat treatment record shall also include photographs and/or sketches providing sufficient accuracy to recreate positions and orientations of the plates in the furnace at future dates. The sketches and/or photographs in the heat treatment record shall be of the furnace car plate-load immediately prior to entering the furnace for the tempering cycle(s). Manufacturer Standard Practices shall be established, which shall include placement of plates, plate support structure (i.e., pylons, saw horses, racks, etc.) on the furnace car, placement of the burners in the furnace, and the distances and orientations of the plates and support structure with respect to the burners. The verification of inspection record shall validate the plate was loaded in accordance with the sketches and/or photographs in the heat treatment record and the Manufacturer Standard Practices.
- d. The quench tank facility used to accomplish the austenitizing heat treatment shall be of a sufficient capacity and design to provide multi-directional (from at least three directions or other effective design based on results of first article testing) water flow for effective quenching of the largest plates to be heat treated. The effectiveness of the quench tank facility in terms of capacity and water flow shall be demonstrated during first article testing. The maximum quench tank water temperature at the initiation of the quenching operation shall not exceed 80 °F.

T9074-BD-GIB-010/0300 Rev 2

F.3.4 Chemical Composition. The chemical analysis, heat and product, shall be as specified in [Table F-1](#).

Table F-1. Chemical Composition (Weight Percent).

Element		Weight Percent (single values are maximums)
Carbon	Heat Analysis	0.12
	Product Analysis	0.14
Manganese	Heat & Product	0.60 – 0.90
Phosphorus	Heat Analysis	0.010
	Product Analysis	0.012
Sulfur	Heat & Product	0.004
Silicon	Heat Analysis	0.15 – 0.35
	Product Analysis	0.13 – 0.37
Nickel	Heat Analysis	4.75 – 5.25
	Product Analysis	4.68 – 5.32
Chromium	Heat & Product	0.40 – 0.70
Molybdenum	Heat & Product	0.30 – 0.65
Copper	Heat & Product	0.25
Niobium (Columbium) <u>1/</u> , <u>2/</u> , <u>3/</u>	Heat & Product	0.02
Aluminum <u>1/</u> , <u>2/</u>	Heat & Product	0.010 – 0.050
Titanium	Heat & Product	0.02
Arsenic <u>5/</u>	Heat & Product	0.025
Antimony <u>5/</u>	Heat & Product	0.025
Vanadium	Heat Analysis	0.05 – 0.10
	Product Analysis	0.04 – 0.11
Tin <u>5/</u>	Heat & Product	0.030
Nitrogen	Heat & Product	120 ppm
Oxygen	Heat & Product	<u>4/</u>
Hydrogen	Heat & Product	<u>4/</u>
NOTES: <u>1/</u> The niobium (columbium) content shall be 0.01 percent when aluminum is added. <u>2/</u> The aluminum content shall be 0.01 percent when niobium (columbium) is added. <u>3/</u> The chemical composition of these elements shall be reported only when intentionally added. <u>4/</u> For information only; 35 ppm oxygen and 3 ppm hydrogen are recommended. <u>5/</u> Element shall not be added intentionally.		

F.3.5 **Tensile Properties.** The material shall meet the tensile property requirements as specified in [Table F-2](#), after final heat treatment.

Table F-2. Tensile Property Requirements (Transverse). 1/

Mechanical Property	HY-130 Nominal Thickness	
	$\frac{3}{16}$ to $\frac{3}{4}$ inch (5 to 19 mm), inclusive	Over $\frac{3}{4}$ inch (19 mm)
Ultimate tensile strength (ksi)	2/	
Yield strength (ksi) [MPa]	130 – 150 [896 – 1034]	130 – 145 [896 – 1000]
Elongation in 2 inches, minimum (percent)	3/	15
Reduction in area, minimum, round specimen (percent)	Not required	50 4/
NOTES: 1/ Two transverse specimens are required per plate. 2/ Not required, to be recorded for information only. 3/ For plates $\frac{3}{16}$ to $\frac{1}{4}$ inch (5 to 6.4 mm), exclusive in thickness, the elongation requirement is 11 percent minimum. For plates $\frac{1}{4}$ to $\frac{3}{8}$ inch (6 to 10 mm), exclusive in thickness, the elongation requirement is 12 percent minimum. For plates $\frac{3}{8}$ to $\frac{3}{4}$ inch (10 to 19 mm) in thickness, the elongation requirement is 14 percent minimum. 4/ When through-thickness tensile testing is required (see F.4.3 and F.4.4.2.4), the only requirement is that the reduction in area shall be a minimum of 20 percent. There are no requirements for yield strength or elongation.		

F.3.6 **Impact Tests.** Impact tests shall be conducted as specified in [Table F-3](#) after final heat treatment.

Table F-3. Impact Test Application.

Plate Thickness, inches (mm)	Applicable Test
Up to $\frac{5}{8}$ (16), inclusive 1/	Charpy V-notch
Over $\frac{5}{8}$ (16) to 6 (152), inclusive 2/	Dynamic tear 3/
NOTES: 1/ For material thicknesses below $\frac{7}{16}$ inch (11 mm), subsized Charpy V-notch test specimens shall be as specified in ASTM A673. Equivalent absorbed energy requirements for subsized specimens shall be as specified (see F.6.2). 2/ Impact properties for nominal plate thicknesses over 6 inches (152 mm) shall be as specified (see F.6.2). 3/ Unless otherwise specified (see F.6.2), Charpy V-notch tests shall also be performed, for information only, on plates over $\frac{5}{8}$ inch (16 mm) thick. Three specimens shall be tested at each temperature of 30 °F (-1 °C) and -120 °F (-84 °C).	

T9074-BD-GIB-010/0300 Rev 2

F.3.6.1 **Impact Properties.** The material shall meet the impact property requirements as specified in [Table F-4](#).

Table F-4. Impact Property Requirements (Transverse). 1/

Temperature °F±3 (°C±2)	Dynamic Tear Test, minimum 2/	Charpy V-notch Test, minimum 3/, 4/	
	ft-lbs [joules]	ft-lbs [joules]	Shear Fracture [percent]
-120 (-84)	----	40 [54]	50
-20 (-29)	500 [678]	----	----
+30 (-1)	600 [814]	80 [109]	95

NOTES:

1/ Sampling and location of test specimens shall be as specified in F.4.4.2.1 and F.4.4.2.5.

2/ Average of test results from two specimens. No single test value shall be below the minimum average by more than 25 ft-lbs [34 J].

3/ Average of test results from three specimens. No single test value shall be below the minimum average by more than 5 ft-lbs [7 J].

4/ Percent shear fracture measurement is required on each Charpy V-notch specimen. No individual result shall be lower than the minimum.

F.3.7 **Stress Relief.** Plates shall not be stress relieved after final heat treatment.

F.3.8 Visual Requirements.

F.3.8.1 **Surface Quality.** The depth of rolled-in scale, pits, or windrowed condition shall not exceed 0.015 inch (0.38 mm) and shall not result in an under gauge (less than minimum thickness) condition. Isolated, individual pits not over 0.030 inch (0.762 mm) deep and separated by more than 6 inches (152 mm) are acceptable, provided they do not reduce the thickness of the plate to an under gauge condition. Surface imperfections may be removed by grinding, provided the thickness is not reduced to an under gauge condition and the ground area is well faired into the surrounding metal.

F.3.8.2 **Weld Repair of Mill Defects Prior to Heat Treatment.** Mill defects may be repair welded. Areas of the plate found to have less than the minimum specified thickness may have thickness restored by welding the depressed area. Welding of such areas shall be subject to the following limitations:

- a. The total area to be repaired shall not exceed 1 percent of the surface of one side of the plate.
- b. The depth of any area to be repaired shall not exceed one-half the minimum plate thickness specified, or ½ inch (13 mm), whichever is smaller. The depth of the area to be repaired shall be a minimum of 1/16 inch (1.6 mm).
- c. Areas within 2 inches (51 mm) of each other which require weld repair shall be combined to form a single repair.
- d. All of the areas to be welded shall be ground sufficiently to assure that the welds are made on clean, sound material.
- e. After preparation for repair and prior to welding, all of the depressed areas shall be magnetic particle inspected in accordance with T9074-AS-GIB-010/271, and shown to be free of linear discontinuities.
- f. Weld repairs shall be made in accordance with T9074-AD-GIB-010/1688 or the applicable fabrication document (see F.3.10) prior to heat treatment, with a procedure qualified in accordance with S9074-AQ-GIB-010/248. Procedures and personnel shall be qualified in accordance with S9074-AQ-GIB-010/248.
- g. The final repaired surface shall be ground smooth and shall be essentially flush with the adjacent surface and free of undercut in excess of 0.020 inch. The finished weld surface shall also be free of underfill.
- h. Plates or segments of plates containing surface repairs as noted above shall be magnetic particle tested in accordance with T9074-AS-GIB-010/271 after final grinding and heat treating to assure freedom from unacceptable discontinuities. Welds and adjacent heat affected zone surfaces shall be free of relevant linear indications longer than 1/8 inch (1.6 mm).
- i. Notations shall be made of such repair areas on the plate inspection form as part of the records.
- j. Repaired areas shall be marked. The markings shall remain legible and shall not be removed prior to performing all inspections required by this specification.

F.3.8.3 Weld Repairs After Heat Treatment. Mill defects found after heat treatment shall be repaired in accordance with F.3.8.2 and subsequently reheat treated, or approval shall be required from the contracting activity for repairing the defects following forming.

F.3.8.4 Edge Defects. Visual laminar edge defects less than ¼ inch (6.4 mm) long are acceptable. Laminar edge defects ¼ inch (6.4 mm) long and over shall be explored by ultrasonic inspection on the plate surface adjacent to the affected area. Edge defects that extend into the plate to the extent that they will result in rejectable defects according to the ultrasonic acceptance standards specified in F.3.9 shall be cause for rejection of the plate. Weld repair of laminar edge defects over ¼ inch (6.4 mm) long shall be in accordance with a qualified weld procedure.

F.3.9 Internal Soundness and Thickness. Material shall be accepted or rejected in accordance with ASTM A435 and shall meet the requirements of Supplement S1 therein. For decimal thickness, plates shall use the procedure of Appendix J and meet the requirements of [Table F-5](#). Recorded thickness measurements and, unless otherwise specified (see F.6.2), internal soundness inspection results shall be prepared and transmitted with the material.

F.3.9.1 Classification and Recording of Internal Soundness. Internal conditions evaluated by ultrasonic inspection shall be classified and recorded in accordance with ASTM A435 and shall meet the supplementary requirements of Supplement S1 therein.

F.3.10 Applicable Fabrication Document. If required (see F.6.2), the applicable fabrication document shall be specified to the plate manufacturer and shall cover the repair and the inspection of the base metal.

F.3.11 Dimensional Tolerances. Tolerances shall be as specified in F.3.11.1 through F.3.11.4.

F.3.11.1 Thickness, Weight, and Gauge. For plate ordered to decimal thickness, the maximum allowable variations in thickness measurements shall be as specified in [Table F-5](#) and [Table F-6](#). For plate ordered to a specific weight basis, the maximum allowable variations in weight and gauge shall be as specified in [Table F-7](#) (see F.6.2).

F.3.11.2 Flatness. Plates shall be flat within the tolerance limits specified in [Table F-8](#). The flatness, as specified in [Table F-8](#), shall be an overall flatness factor. This factor shall not apply to “kinks” or “waviness”. The waviness or kinking permitted shall be judged by laying a 3-foot (1-meter) straightedge across the affected edges. The maximum permissible deviation from the straightedge shall be ¼ inch (6.4 mm). When specified (see F.6.2), tighter requirements may be required.

T9074-BD-GIB-010/0300 Rev 2

Table F-5. Thickness Tolerances in Inches and Millimeters (Average) Over Ordered Thickness for Single Plate 2 Inches (51 mm) and Under in Thickness. 1/, 2/

Specified Thickness, inches (mm)	Tolerance Over Ordered Thickness for Widths Given, inch (mm)											
	48 (1219) or under	48 (1219) to 60 (1524), exclusive	60 (1524) to 72 (1829), exclusive	72 (1829) to 84 (2133), exclusive	84 (2133) to 96 (2438), exclusive	96 (2438) to 108 (2743), exclusive	108 (2743) to 120 (3048), exclusive	120 (3048) to 132 (3353), exclusive	132 (3353) to 144 (3658), exclusive	144 (3658) to 168 (4267), exclusive	168 (4267) to 182 (4623), exclusive	182 (4623) and over
$\frac{3}{16}$ (4.8)	0.027 (0.7)	0.027 (0.7)	0.027 (0.7)	0.027 (0.7)	0.027 (0.7)	0.027 (0.7)	3/16 (4.8)	---	---	---	---	---
$\frac{1}{4}$ (6.4)	0.015 (0.4)	0.015 (0.4)	0.021 (0.5)	0.021 (0.5)	0.027 (0.7)	0.027 (0.7)	0.035 (0.9)	---	---	---	---	---
$\frac{5}{16}$ (7.9)	0.015 (0.4)	0.015 (0.4)	0.021 (0.5)	0.027 (0.7)	0.027 (0.7)	0.027 (0.7)	0.035 (0.9)	0.042 (1.1)	---	---	---	---
$\frac{3}{8}$ (9.5)	0.015 (0.4)	0.015 (0.4)	0.021 (0.5)	0.027 (0.7)	0.027 (0.7)	0.035 (0.9)	0.035 (0.9)	0.042 (1.1)	---	---	---	---
$\frac{7}{16}$ (11.1)	0.015 (0.4)	0.015 (0.4)	0.021 (0.5)	0.027 (0.7)	0.027 (0.7)	0.035 (0.9)	0.042 (1.1)	0.042 (1.1)	0.052 (1.3)	---	---	---
$\frac{1}{2}$ (12.7)	0.021 (0.5)	0.021 (0.5)	0.021 (0.5)	0.027 (0.7)	0.027 (0.7)	0.035 (0.9)	0.042 (1.1)	0.042 (1.1)	0.052 (1.3)	0.062 (1.6)	---	---
$\frac{9}{16}$ (14.3)	0.021 (0.5)	0.021 (0.5)	0.027 (0.7)	0.027 (0.7)	0.027 (0.7)	0.035 (0.9)	0.042 (1.1)	0.052 (1.3)	0.052 (1.3)	0.062 (1.6)	---	---
$\frac{5}{8}$ (15.9)	0.027 (0.7)	0.027 (0.7)	0.027 (0.7)	0.027 (0.7)	0.027 (0.7)	0.035 (0.9)	0.042 (1.1)	0.052 (1.3)	0.052 (1.3)	0.062 (1.6)	0.069 (1.8)	0.076 (1.9)
$\frac{11}{16}$ (17.5)	0.027 (0.7)	0.027 (0.7)	0.027 (0.7)	0.027 (0.7)	0.027 (0.7)	0.035 (0.9)	0.042 (1.1)	0.052 (1.3)	0.052 (1.3)	0.062 (1.6)	0.069 (1.8)	0.076 (1.9)
$\frac{3}{4}$ (19.1)	0.027 (0.7)	0.027 (0.7)	0.027 (0.7)	0.027 (0.7)	0.035 (0.9)	0.035 (0.9)	0.042 (1.1)	0.052 (1.3)	0.068 (1.7)	0.075 (1.9)	0.077 (2.0)	0.086 (2.2)
$\frac{13}{16}$ (20.6)	0.027 (0.7)	0.035 (0.9)	0.035 (0.9)	0.035 (0.9)	0.035 (0.9)	0.042 (1.1)	0.052 (1.3)	0.052 (1.3)	0.068 (1.7)	0.075 (1.9)	0.085 (2.2)	0.095 (2.4)
$\frac{7}{8}$ (22.2)	0.035 (0.9)	0.035 (0.9)	0.035 (0.9)	0.035 (0.9)	0.042 (1.1)	0.042 (1.1)	0.052 (1.3)	0.062 (1.6)	0.068 (1.7)	0.075 (1.9)	0.085 (2.2)	0.095 (2.4)
$\frac{15}{16}$ (23.8)	0.035 (0.9)	0.035 (0.9)	0.035 (0.9)	0.035 (0.9)	0.042 (1.1)	0.042 (1.1)	0.052 (1.3)	0.062 (1.6)	0.075 (1.9)	0.085 (2.2)	0.093 (2.4)	0.107 (2.7)
1 (25.4)	0.035 (0.9)	0.035 (0.9)	0.042 (1.1)	0.042 (1.1)	0.042 (1.1)	0.042 (1.1)	0.052 (1.3)	0.062 (1.6)	0.075 (1.9)	0.085 (2.2)	0.093 (2.4)	0.107 (2.7)
$1\frac{1}{16}$ (27.0)	0.035 (0.9)	0.035 (0.9)	0.042 (1.1)	0.024 (1.1)	0.042 (1.1)	0.052 (1.3)	0.052 (1.3)	0.062 (1.6)	0.075 (1.9)	0.085 (2.2)	0.096 (2.4)	0.107 (2.7)
$1\frac{1}{8}$ (28.6)	0.042 (1.1)	0.042 (1.1)	0.042 (1.1)	0.042 (1.1)	0.042 (1.1)	0.052 (1.3)	0.052 (1.3)	0.068 (1.7)	0.075 (1.9)	0.085 (2.2)	0.096 (2.4)	0.107 (2.7)
$1\frac{3}{16}$ (30.2)	0.042 (1.1)	0.042 (1.1)	0.052 (1.3)	0.052 (1.3)	0.052 (1.3)	0.052 (1.3)	0.062 (1.6)	0.075 (1.9)	0.085 (2.2)	0.095 (2.4)	0.102 (2.6)	0.117 (3.0)
$1\frac{1}{4}$ (31.8)	0.042 (1.1)	0.042 (1.1)	0.052 (1.3)	0.052 (1.3)	0.052 (1.3)	0.062 (1.6)	0.062 (1.6)	0.075 (1.9)	0.085 (2.2)	0.095 (2.4)	0.106 (2.7)	0.117 (3.0)
$1\frac{5}{16}$ (33.3)	0.042 (1.1)	0.042 (1.1)	0.052 (1.3)	0.052 (1.3)	0.052 (1.3)	0.062 (1.6)	0.062 (1.6)	0.075 (1.9)	0.095 (2.4)	0.105 (2.7)	0.115 (2.9)	0.125 (3.2)
$1\frac{3}{8}$ (34.9)	0.047 (1.2)	0.052 (1.3)	0.052 (1.3)	0.052 (1.3)	0.052 (1.3)	0.062 (1.6)	0.068 (1.7)	0.085 (2.2)	0.095 (2.4)	0.105 (2.7)	0.115 (2.9)	0.125 (3.2)
$1\frac{7}{16}$ (36.5)	0.047 (1.2)	0.052 (1.3)	0.062 (1.6)	0.062 (1.6)	0.062 (1.6)	0.062 (1.6)	0.075 (1.9)	0.085 (2.2)	0.105 (2.7)	0.115 (2.9)	0.125 (3.2)	0.135 (3.4)
$1\frac{1}{2}$ (38.1)	0.052 (1.3)	0.052 (1.3)	0.062 (1.6)	0.062 (1.6)	0.062 (1.6)	0.068 (1.7)	0.075 (1.9)	0.085 (2.2)	0.105 (2.7)	0.115 (2.9)	0.125 (3.2)	0.135 (3.4)
$1\frac{9}{16}$ (39.7)	0.052 (1.3)	0.052 (1.3)	0.062 (1.6)	0.062 (1.6)	0.062 (1.6)	0.068 (1.7)	0.075 (1.9)	0.095 (2.4)	0.105 (2.7)	0.130 (3.3)	0.145 (3.7)	0.160 (4.1)
$1\frac{5}{8}$ (41.3)	0.062 (1.6)	0.062 (1.6)	0.062 (1.6)	0.062 (1.6)	0.062 (1.6)	0.075 (1.9)	0.085 (2.2)	0.095 (2.4)	0.115 (2.9)	0.130 (3.3)	0.145 (3.7)	0.160 (4.1)
$1\frac{11}{16}$ (42.9)	0.062 (1.6)	0.062 (1.6)	0.068 (1.7)	0.068 (1.7)	0.068 (1.7)	0.075 (1.9)	0.085 (2.2)	0.105 (2.7)	0.115 (2.9)	0.130 (3.3)	0.145 (3.7)	0.160 (4.1)
$1\frac{3}{4}$ (44.5)	0.062 (1.6)	0.062 (1.6)	0.068 (1.7)	0.068 (1.7)	0.068 (1.7)	0.075 (1.9)	0.085 (2.2)	0.105 (2.7)	0.125 (3.2)	0.145 (3.7)	0.165 (4.2)	0.185 (4.7)
$1\frac{13}{16}$ (46.0)	0.062 (1.6)	0.062 (1.6)	0.075 (1.9)	0.075 (1.9)	0.075 (1.9)	0.085 (2.2)	0.095 (2.4)	0.105 (2.7)	0.125 (3.2)	0.145 (3.7)	0.165 (4.2)	0.185 (4.7)
$1\frac{7}{8}$ (47.6)	0.062 (1.6)	0.062 (1.6)	0.075 (1.9)	0.075 (1.9)	0.075 (1.9)	0.085 (2.2)	0.095 (2.4)	0.115 (2.9)	0.125 (3.2)	0.145 (3.7)	0.165 (4.2)	0.185 (4.7)
$1\frac{15}{16}$ (49.2)	0.068 (1.7)	0.068 (1.7)	0.075 (1.9)	0.075 (1.9)	0.075 (1.9)	0.085 (2.2)	0.095 (2.4)	0.115 (2.9)	0.141 (3.6)	0.157 (4.0)	0.174 (4.4)	0.190 (4.8)
2 (50.8)	0.068 (1.7)	0.068 (1.7)	0.075 (1.9)	0.075 (1.9)	0.075 (1.9)	0.085 (2.2)	0.095 (2.4)	0.115 (2.9)	0.141 (3.6)	0.157 (4.0)	0.174 (4.4)	0.190 (4.8)

NOTES:

1/ Tolerance under specified thickness, 0.01 inch (0.3 mm).

2/ For intermediate thickness, the tolerance of the closer specified gauge shall apply. In case of mid-point, the tolerance for the lower gauge or interpolated value shall apply.

Table F-6. Thickness Tolerances in Inches (mm) (Average) Over Ordered Thickness for a Single Plate Over 2 Inches (51 mm) Thick When Ordered to Thickness in Inches (mm). 1/, 2/

Specified Thickness, inches (mm)	Tolerances Over Specified Thickness for Widths Given					
	To 36 (914), exclusive	36 (914) to 60 (1524), exclusive	60 (1524) to 84 (2134), exclusive	84 (2134) to 120 (3048), exclusive	120 (3048) to 132 (3353), exclusive	132 (3353) and over
Over 2 (50.8) to 3 (76.2), exclusive	0.063 (1.6)	0.094 (2.4)	0.109 (2.8)	0.125 (3.2)	0.125 (3.2)	0.141 (3.6)
3 (76.2) to 4 (101.6), exclusive	0.078 (2.0)	0.094 (2.4)	0.109 (2.8)	0.125 (3.2)	0.125 (3.2)	0.141 (3.6)
4 (101.6) to 6 (152.4), exclusive	0.094 (2.4)	0.125 (3.2)	0.141 (3.6)	0.156 (4.0)	0.156 (4.0)	0.172 (4.4)
6 (152.4) to 8 (203.2), exclusive	0.109 (2.8)	0.125 (3.2)	0.156 (4.0)	0.172 (4.4)	0.172 (4.4)	----
NOTES:						
<u>1/</u> Tolerance under specified thickness, 0.01 inch (0.3 mm).						
<u>2/</u> For intermediate thickness, the tolerance of the closer gauge shall apply. In case of mid-point, the tolerance for the lower gauge or interpolated value shall apply.						

T9074-BD-GIB-010/0300 Rev 2

Table F-7. Allowable Variation in Weight and Gauge for Plates Specified on a Weight Basis (Applicable to Single Plates).

Allowable Under Gauge at Edge for Widths Given, inches (mm)									
Specified Weight, lb/ft ² [kg/m ²] {Thickness, inch (mm)}	Up to 66 (1676), inclusive	Over 66 (1676) to 80 (2032), inclusive	Over 80 (2032) to 90 (2286), inclusive	Over 90 (2286) to 100 (2540), inclusive	Over 100 (2540) to 115 (2921), inclusive	Over 115 (2921) to 135 (3429), inclusive	Over 135 (3429) to 150 (3810), inclusive	Over 150 (3810) to 168 (4267), inclusive	Over 168 (4267)
	Percent	Percent	Percent	Percent	Percent	Percent	Percent	Percent	Percent
To 20.4 [100], exclusive {½ (13)}	6	6	8	8	8	8	8	8	8
20.4 [100] to 25.5 [125], exclusive {½ (13) to ⅝ (15.8)}	3.5	4	4.5	5	5.5	6.5	6.5	6.5	6.5
25.5 [125] to 30.6 [150], exclusive {⅝ (15.8) to ¾ (19)}	3.5	4	4.5	5	5.5	6	6	6	6
30.6 [150] to 40.8 [199], exclusive {¾ (19) to 1 (25)}	3	3	3.5	4	4	4.5	5	5.5	6
40.8 [199] and over {1 (25)}	3	3	3	3	3	3.5	4	4.5	5
Allowable Weight Tolerance for Widths Given, inches (mm)									
Specified Weight, lb/ft ² [kg/m ²] {Thickness, inch (mm)}	Up to 150 (3810), inclusive		Over 150 (3810) to 168 (4267), inclusive		Over 168 (4267)				
	Percent		Percent		Percent				
	Over	Under	Over	Under	Over	Under			
To 20.4 [100], exclusive {½ (13)}	8	10	---	---	---	---			
20.4 [100] to 25.5 [125], exclusive {½ (13) to ⅝ (15.8)}	2	4	---	---	---	---			
25.5 [125] to 30.6 [150], exclusive {⅝ (15.8) to ¾ (19)}	2	4	---	---	---	---			
30.6 [150] to 40.8 [199], exclusive {¾ (19) to 1 (25)}	2	3.5	3	4	3	4			
40.8 [199] and over {1 (25)}	2	3	2	3	3	4			

Table F-8. Flatness Tolerances for Plates Ordered on a lb/ft² [kg/m²] or Inch (mm) Basis. 1/, 2/, 3/

Specified Thickness, inches (mm)	Specified Weight, lb/ft ² [kg/m ²]	Flatness Tolerance for Specified Widths, inches (mm)										
		Up to 36 (941), exclusive	36 (941) to 48 (1219), exclusive	48 (1219) to 60 (1524), exclusive	60 (1524) to 72 (1829), exclusive	72 (1829) to 84 (2134), exclusive	84 (2134) to 96 (2438), exclusive	96 (2438) to 108 (2743), exclusive	108 (2743) to 120 (3048), exclusive	120 (3048) to 144 (3658), exclusive	144 (3658) to 168 (4267), exclusive	168 (4267) and over
To ¼ (6), exclusive	To 10.2 [49.8], exclusive	⅓ (21)	1⅛ (29)	1⅜ (35)	1⅞ (48)	2 (51)	2¼ (57)	2⅝ (60)	2⅞ (67)	2¾ (70)	---	---
¼ (6) to ⅜ (10), exclusive	10.2 [49.8] to 15.3 [74.8], exclusive	¾ (19)	1⅝ (24)	1⅞ (29)	1⅜ (35)	1¾ (45)	1⅞ (48)	2 (51)	2¼ (57)	2⅜ (60)	---	---
⅜ (10) to ½ (13), exclusive	15.3 [74.8] to 20.4 [99.7], exclusive	¾ (19)	⅞ (22)	1⅝ (24)	1⅝ (24)	1⅞ (29)	1⅝ (33)	1½ (38)	1⅝ (41)	1⅞ (48)	2¾ (70)	3⅞ (79)
½ (13) to ¾ (19), exclusive	20.4 [99.7] to 30.6 [149.5], exclusive	⅝ (16)	¾ (19)	1⅜ (21)	⅞ (22)	1 (25)	1⅞ (29)	1¼ (32)	1⅜ (35)	1⅝ (41)	2¼ (57)	3 (76)
¾ (19) to 1 (25), exclusive	30.6 [149.5] to 40.8 [199.4], exclusive	⅝ (16)	¾ (19)	⅞ (22)	⅞ (22)	1⅝ (24)	1 (25)	1⅞ (29)	1⅝ (33)	1½ (38)	2 (51)	2⅝ (67)
1 (25) to 2 (51), exclusive	40.8 [199.4] to 81.6 [398.8], exclusive	⅞ (14)	⅝ (16)	¾ (19)	1⅜ (21)	⅞ (22)	1⅝ (24)	1 (25)	1 (25)	1 (25)	1⅝ (41)	2¼ (57)
2 (51) to 4 (102), exclusive	81.6 [398.8] to 163.2 [798], exclusive	½ (13)	⅞ (14)	1⅜ (18)	¾ (19)	¾ (19)	¾ (19)	¾ (19)	⅞ (22)	1 (25)	1¼ (32)	1⅝ (41)
4 (102) to 6 (152), exclusive	163.2 [798] to 244.8 [1196], exclusive	⅞ (14)	1⅜ (18)	¾ (19)	¾ (19)	⅞ (22)	⅞ (22)	1⅝ (24)	1⅞ (29)	1¼ (32)	1¼ (32)	1½ (38)
6 (152) to 8 (203), exclusive	244.8 [1196] to 326.4 [1595], exclusive	⅝ (16)	¾ (19)	¾ (19)	1⅝ (24)	1 (25)	1⅞ (29)	1¼ (32)	1⅝ (33)	1½ (38)	1½ (38))	1½ (38)
8 (203) to 10 (254), exclusive	326.4 [1595] to 418.0 [2043], exclusive	¾ (19)	1⅜ (21)	1⅝ (24)	1 (25)	1⅞ (29)	1¼ (32)	1⅝ (33)	1⅜ (35)	1½ (38)	1½ (38)	1½ (38)
10 (254) to 12 (305), exclusive	418.0 [2043] to 489.6 [2393], exclusive	¾ (19)	1⅝ (24)	1⅞ (29)	1¼ (32)	1⅝ (33)	1⅜ (35)	1½ (38)	1½ (38)	1½ (38)	1½ (38)	1½ (38)
12 (305) to 15 (381), exclusive	489.6 [2393] to 612 [2991], exclusive	⅞ (22)	1 (25)	1⅜ (30)	1⅝ (33)	1⅜ (35)	1½ (38)	1½ (38)	1½ (38)	1½ (38)	1½ (38)	1½ (38)

NOTES:

1/ Flatness tolerances for length and width. The longer dimension specified is considered the length. Variation from a flat surface along the length shall not exceed the tabular amount for the specified width in any 12 feet (4 meters) of length.

2/ When the longer dimension is under 36 inches (1 meter), the variation in flatness shall not exceed ¼ inch (6.4 mm).

3/ The above table and notes also cover the flatness tolerances of circular and sketch plates, based on the maximum dimensions of those plates.

T9074-BD-GIB-010/0300 Rev 2

F.3.11.3 **Camber.** Camber of the plates shall not exceed the tolerance limits specified in [Table F-9](#).

Table F-9. Camber Tolerances for Plates Ordered on a lb/ft² [kg/m²] or Inch (mm) Basis.

Specified Weight, lb/ft ² [kg/m ²]	Thickness, inches (mm)	Width, inches (mm)	Camber Tolerance for Thickness and Width Given		
To 81.6 [399], inclusive	To 2 (51), inclusive	All	1/8 inch	X	<u>length (feet)</u> 5
			3 mm	X	<u>length (meters)</u> 1.524
----	Over 2 (51) to 8 (203), exclusive	To 30 (762), inclusive	3/16 inch	X	<u>length (feet)</u> 5
			5 mm	X	<u>length (meters)</u> 1.524
----	Over 2 (51) to 8 (203), exclusive	Over 30 (762) to 60 (1524), inclusive	1/4 inch	X	<u>length (feet)</u> 5
			6.4 mm	X	<u>length (meters)</u> 1.524

F.3.11.4 **Size Tolerances.** The width and length of the plates shall not vary in excess of the tolerances specified in [Table F-10](#) and [Table F-11](#).

Table F-10. Width and Length Tolerances for Sheared Plates 1 Inch (25 mm) Thick or Less. ^{1/}

Specified Dimensions, inches (mm)		Maximum Permissible Variations Over Specific Width and Length for Weight or Thickness Given					
Width	Length	To $\frac{3}{8}$ inch (10 mm), exclusive		$\frac{3}{8}$ to $\frac{5}{8}$ inch (10 to 16 mm), exclusive		$\frac{5}{8}$ to 1 inch (16 to 25 mm), exclusive	
		Under 15.3 lb/ft ² [74.8 kg/m ²], exclusive		15.3 to 25.5 lb/ft ² [74.8 to 124.6 kg/m ²], exclusive		25.5 to 40.8 lb/ft ² [124.6 to 199.4 kg/m ²], exclusive	
		Width, inch (mm)	Length, inch (mm)	Width, inch (mm)	Length, inch (mm)	Width, inch (mm)	Length, inch (mm)
To 60 (1524), exclusive	To 120 (3048), exclusive	$\frac{3}{8}$ (10)	$\frac{1}{2}$ (130)	$\frac{7}{16}$ (11)	$\frac{5}{8}$ (16)	$\frac{1}{2}$ (13)	$\frac{3}{4}$ (19)
60 (1524) to 84 (2134), exclusive		$\frac{7}{16}$ (11)	$\frac{5}{8}$ (16)	$\frac{1}{2}$ (13)	$\frac{11}{16}$ (18)	$\frac{5}{8}$ (16)	$\frac{7}{8}$ (22)
84 (2134) to 108 (2743), exclusive		$\frac{1}{2}$ (13)	$\frac{3}{4}$ (19)	$\frac{5}{8}$ (16)	$\frac{7}{8}$ (22)	$\frac{3}{4}$ (19)	1 (25)
108 (2743) and over		$\frac{5}{8}$ (16)	$\frac{7}{8}$ (22)	$\frac{3}{4}$ (19)	1 (25)	$\frac{7}{8}$ (22)	$1\frac{1}{8}$ (29)
To 60 (1524), exclusive	120 (3048) to 240 (6096), exclusive	$\frac{3}{8}$ (10)	$\frac{3}{4}$ (19)	$\frac{1}{2}$ (13)	$\frac{7}{8}$ (22)	$\frac{5}{8}$ (16)	1 (25)
60 (1524) to 84 (2134), exclusive		$\frac{1}{2}$ (13)	$\frac{3}{4}$ (19)	$\frac{5}{8}$ (16)	$\frac{7}{8}$ (22)	$\frac{3}{4}$ (19)	1 (25)
84 (2134) to 108 (2743), exclusive		$\frac{9}{16}$ (14)	$\frac{7}{8}$ (22)	$\frac{11}{16}$ (18)	$\frac{15}{16}$ (24)	$\frac{13}{16}$ (21)	$1\frac{1}{8}$ (29)
108 (2743) and over		$\frac{5}{8}$ (16)	1 (25)	$\frac{3}{4}$ (19)	$1\frac{3}{16}$ (30)	$\frac{7}{8}$ (22)	$1\frac{1}{4}$ (32)
To 60 (1524), exclusive	240 (6096) to 360 (9144), exclusive	$\frac{3}{8}$ (10)	$1\frac{1}{16}$ (27)	$\frac{1}{2}$ (13)	$1\frac{3}{16}$ (30)	$\frac{5}{8}$ (16)	$1\frac{5}{16}$ (33)
60 (1524) to 84 (2134), exclusive		$\frac{1}{2}$ (13)	$1\frac{1}{16}$ (27)	$\frac{5}{8}$ (16)	$1\frac{3}{16}$ (30)	$\frac{3}{4}$ (19)	$1\frac{5}{16}$ (33)
84 (2134) to 108 (2743), exclusive		$\frac{9}{16}$ (14)	$1\frac{1}{16}$ (27)	$\frac{11}{16}$ (18)	$1\frac{3}{16}$ (30)	$\frac{7}{8}$ (22)	$1\frac{7}{16}$ (37)
108 (2743) and over		$\frac{11}{16}$ (18)	$1\frac{3}{16}$ (30)	$\frac{7}{8}$ (22)	$1\frac{5}{16}$ (33)	1 (25)	$1\frac{7}{16}$ (37)
To 60 (1524), exclusive	360 (9144) to 480 (12192), exclusive	$\frac{7}{16}$ (11)	$1\frac{3}{16}$ (30)	$\frac{1}{2}$ (13)	$1\frac{5}{16}$ (33)	$\frac{5}{8}$ (16)	$1\frac{7}{16}$ (37)
60 (1524) to 84 (2134), exclusive		$\frac{1}{2}$ (13)	$1\frac{5}{16}$ (33)	$\frac{5}{8}$ (16)	$1\frac{7}{16}$ (37)	$\frac{3}{4}$ (19)	$1\frac{9}{16}$ (40)
84 (2134) to 108 (2743), exclusive		$\frac{9}{16}$ (14)	$1\frac{5}{16}$ (33)	$\frac{3}{4}$ (19)	$1\frac{7}{16}$ (37)	$\frac{7}{8}$ (22)	$1\frac{9}{16}$ (40)
108 (2743) and over		$\frac{3}{4}$ (19)	$1\frac{7}{16}$ (37)	$\frac{7}{8}$ (22)	$1\frac{9}{16}$ (40)	1 (25)	$1\frac{11}{16}$ (43)
To 60 (1524), exclusive	480 (12192) to 600 (15240), exclusive	$\frac{7}{16}$ (11)	$1\frac{3}{8}$ (35)	$\frac{1}{2}$ (13)	$1\frac{5}{8}$ (41)	$\frac{5}{8}$ (16)	$1\frac{3}{4}$ (45)
60 (1524) to 84 (2134), exclusive		$\frac{1}{2}$ (13)	$1\frac{1}{2}$ (38)	$\frac{5}{8}$ (16)	$1\frac{5}{8}$ (41)	$\frac{3}{4}$ (19)	$1\frac{3}{4}$ (45)
84 (2134) to 108 (2743), exclusive		$\frac{5}{8}$ (16)	$1\frac{1}{2}$ (38)	$\frac{3}{4}$ (19)	$1\frac{5}{8}$ (41)	$\frac{7}{8}$ (22)	$1\frac{3}{4}$ (45)
108 (2743) and over		$\frac{3}{4}$ (19)	$1\frac{5}{8}$ (41)	$\frac{7}{8}$ (22)	$1\frac{3}{4}$ (45)	1 (25)	$1\frac{7}{8}$ (48)
To 60 (1524), exclusive	600 (15240) to 720 (18288), exclusive	$\frac{1}{2}$ (13)	$1\frac{7}{8}$ (48)	$\frac{5}{8}$ (16)	2 (51)	$\frac{3}{4}$ (19)	2 (51)
60 (1524) to 84 (2134), exclusive		$\frac{5}{8}$ (16)	$1\frac{7}{8}$ (48)	$\frac{3}{4}$ (19)	2 (51)	$\frac{7}{8}$ (22)	2 (51)
84 (2134) to 108 (2743), exclusive		$\frac{5}{8}$ (16)	$1\frac{7}{8}$ (48)	$\frac{3}{4}$ (19)	2 (51)	$\frac{7}{8}$ (22)	2 (51)
108 (2743) and over		$\frac{7}{8}$ (22)	$1\frac{7}{8}$ (48)	1 (25)	$2\frac{1}{8}$ (54)	$1\frac{1}{8}$ (29)	$2\frac{3}{8}$ (60)
To 60 (1524), exclusive	720 (18288) and over	$\frac{9}{16}$ (14)	$2\frac{1}{8}$ (54)	$\frac{3}{4}$ (19)	$2\frac{1}{4}$ (57)	$\frac{7}{8}$ (22)	$2\frac{3}{8}$ (60)
60 (1524) to 84 (2134), exclusive		$\frac{3}{4}$ (19)	$2\frac{1}{8}$ (54)	$\frac{7}{8}$ (22)	$2\frac{1}{4}$ (57)	1 (25)	$2\frac{3}{8}$ (60)
84 (2134) to 108 (2743), exclusive		$\frac{3}{4}$ (19)	$2\frac{1}{8}$ (54)	$\frac{7}{8}$ (22)	$2\frac{1}{4}$ (57)	1 (25)	$2\frac{3}{8}$ (60)
108 (2743) and over		1 (25)	$2\frac{1}{8}$ (54)	$1\frac{1}{8}$ (29)	$2\frac{1}{2}$ (64)	$1\frac{1}{4}$ (32)	$2\frac{5}{8}$ (67)

NOTES:

^{1/} Maximum permissible variation under specified width and length is $\frac{1}{4}$ inch (6.4 mm).

T9074-BD-GIB-010/0300 Rev 2

Table F-11. Width and Length Tolerances for Gas-Cut Rectangular Plates. 1/

Specified Thicknesses, inches (mm)	Tolerances Over for all Specified Widths or Lengths, inches (mm)
To 2 (51), exclusive	$\frac{3}{4}$ (19)
2 (51) to 4 (102), exclusive	1 (25)
4 (102) to 6 (152), exclusive	$1\frac{1}{8}$ (29)
6 (152) to 8 (203), exclusive	$1\frac{5}{16}$ (33)
NOTES:	
1/ Maximum permissible variation under specified width and length is $\frac{1}{4}$ inch (6.4 mm).	

F.3.12 Explosion Test. Explosion testing is required as part of first article testing and is not required for conformance testing. Two explosion crack starter tests are required for first article testing. Both specimens shall conform to the crack starter configuration requirements on [Figure L-8](#) and meet the explosion crack starter requirements in Appendix L. A minimum of 3 percent reduction in thickness shall be obtained on the two required crack starter shots. When explosion bulge type testing is specified along with any requirements for additional tests and minimum percent reduction in thickness (see F.6.2), testing shall be in accordance with Appendix L.

F.3.13 Cleaning and Preservation of Plate Surfaces. Unless otherwise specified (see F.6.2), the surface of the plate shall be descaled and coated as specified in Appendix K.

F.3.14 Marking. Each plate shall be indentation stamped with the heat number, plate number, and the designation HY-130. The primary rolling direction and top of the plate corresponding to the hot top of the ingot shall be identified. In addition, plates shall be marked to designate the ultrasonic reference base location (see ASTM A435). The marking may be painted or stenciled in lieu of die stamping on plate $\frac{1}{4}$ inch (6.4 mm) thick or less. Where the plate number provides positive identification of the heat number, the heat number may be omitted from the markings. Identification stamping shall be done with round nose dies.

F.4 VERIFICATION.

F.4.1 Responsibility for Inspection. See 4.1.

F.4.2 Classification of Inspections. The inspection requirements specified herein are classified as follows:

- a. First article inspection (see F.4.3).
- b. Conformance inspection (see F.4.4).

F.4.3 First Article Inspection. First article inspection shall consist of the examinations and tests specified in [Table F-12](#) (see 4.3, 6.3, and Appendix L). Chemical composition, tensile, and impact specimens for first article testing shall be located and tested as specified on [Figure F-1](#) and [Figure F-2](#), unless otherwise specified (see F.6.2). As a minimum, plate thicknesses of 1 inch (25 mm), 2 inches (51 mm), and the thickest gauge to be produced at the mill shall be tested. A first article inspection report shall be prepared as specified in 3.1.

Table F-12. First Article and Conformance Inspection Requirements.

Examination and Tests	Requirement	Test Method	First Article	Conformance
Chemical analysis	F.3.4	4.5.1 and F.4.6.1	X	X
Tensile properties	F.3.5	4.5.2 and F.4.6.2	X	X
Explosion	F.3.12	4.5.5 and F.4.6.4	X	---
Impact Properties				
Charpy V-notch	F.3.6.1	4.5.3 and F.4.6.3	X	X
Dynamic tear	F.3.6.1	4.5.4 and F.4.6.3	X	X
Examination				
Surface quality	F.3.8	F.4.5	X	X
Dimensional	F.3.11	F.4.6.5	X	X
Internal soundness	F.3.9	F.4.6.5	X	X

F.4.4 **Conformance Inspection.** Conformance inspection (i.e., inspections of production lots) shall consist of the examinations and tests specified in [Table F-12](#). Each lot shall be inspected (see F.4.4.1).

F.4.4.1 **Lot Definitions.**

F.4.4.1.1 **Lot for Tension Tests.** Each plate as-heat-treated shall constitute a lot.

F.4.4.1.2 **Lot for Impact Tests.** Each plate as-heat-treated shall constitute a lot.

F.4.4.1.3 **Lot for Examination and Inspection.** For purposes of visual and dimensional examination and nondestructive inspection, each plate as submitted for final inspection shall constitute a lot.

F.4.4.2 **Sampling for Conformance Inspection.** Samples shall be taken for examination and testing as follows:

F.4.4.2.1 **Location of Test Specimens in Plate.** The specimens shall be located as shown on [Figure F-3](#) and [Figure F-4](#). [Figure F-3](#) shall be used when the final direction of rolling is parallel to the longitudinal axis of the ingot. [Figure F-4](#) shall be used when the final rolling direction is parallel to the transverse axis of the ingot. The final direction of rolling is the direction of rolling in which the greatest reduction ratio was achieved.

F.4.4.2.2 **Sampling for Examination and Inspection.** Each plate shall be examined visually, ultrasonically, and dimensionally. With respect to coating applications, the number of plates subject to paint film thickness measurements should be held to the minimum necessary to assure continued satisfactory performance.

F.4.4.2.3 **Sampling for Chemical and Spectrographic Analysis.** Samples for chemical or spectrographic analysis shall be taken from the top center, mid-thickness position of the top plate from each ingot, in each lot (see [Figure F-3](#) and [Figure F-4](#)). Solid samples shall be removed from the rolling-direction centerline of the plate at mid-thickness of the plate.

F.4.4.2.4 **Sampling for Tensile Test.** After final heat treatment of the plate, one top transverse tensile test specimen and one bottom transverse tensile test specimen shall be taken from each plate. In addition, for plate thicknesses of 3 inches or greater, a through-thickness tensile specimen shall be taken from the same location as the sample for chemical analysis (see F.4.4.2.3). The tensile test specimens for plate $\frac{3}{4}$ inch (19 mm) and under in thickness shall be the thickness of the plate. The test specimens shall conform to the requirements for rectangular tension test specimens of ASTM A370. Either the $\frac{1}{2}$ -inch (38-mm) wide specimen or the $\frac{1}{2}$ -inch (13-mm) wide specimen is acceptable. The $\frac{1}{2}$ -inch (13-mm) wide specimen shall have a maximum nominal thickness of $\frac{3}{4}$ inch (19 mm). For plates up to 4 inches (102 mm), inclusive, in thickness, tension test specimens may be full thickness of the plate and conform to the requirements of the $\frac{1}{2}$ -inch (38-mm) wide specimen of ASTM A370 when adequate testing machine capacity is available. For plates over $\frac{3}{4}$ inch (19 mm) in thickness, except as permitted previously, tensile test specimens shall conform to the 0.500-inch round specimen of ASTM A370. One surface of the specimen shall be as near as practicable to T/2 for plate less than or equal to 4 inches thick and as near as practicable to T/4 or 2 inches, whichever is greater, for plate greater than 4 inches thick.

F.4.4.2.5 **Sampling for Impact Test.**

F.4.4.2.5.1 **Charpy V-Notch Testing.** From each plate, three transverse Charpy V-notch test specimens shall be taken from each location for each test temperature (see [Figure F-3](#) and [Figure F-4](#), as applicable, for locations). The specimens shall be in accordance with ASTM A370. The specimens shall be so located in the thickness of the plate that, for $\frac{1}{2}$ inch

T9074-BD-GIB-010/0300 Rev 2

(13 mm) thick to $\frac{7}{8}$ inch (22 mm) thick, the plate surface (after light machining) shall be one face; for plates $\frac{7}{8}$ inch (22 mm) thick to 4 inches (102 mm) thick, inclusive, the mid-thickness of the plate shall be the mid-thickness of the specimens; and, for plates 4 inches (102 mm) to 6 inches (152 mm) thick, inclusive, the mid-thickness of the specimen shall be the quarter thickness of the plate or 2 inches, whichever is greater. The notch shall be perpendicular to the plate surface. The specimens shall be located not less than three times the plate thickness or 4 inches (102 mm), whichever is less, from the as-heat-treated edge of the plate.

F.4.4.2.5.2 Dynamic Tear Testing. From each plate, two transverse dynamic tear test specimens shall be taken from each location for each test temperature. The test specimens shall be in accordance with ASTM E604. The dynamic tear specimen shall be located in the thickness of the plate such that the mid-thickness of the plate shall be the mid-thickness of the specimen for plate thicknesses to 4 inches (102 mm), inclusive. For plates greater than 4 inches (102 mm) to 6 inches (152 mm), inclusive, the mid-thickness of the specimen shall be the quarter thickness of the plate or 2 inches, whichever is greater. The notch shall be perpendicular to the plate surfaces. The specimens shall be located not less than three times the plate thickness or 4 inches (102 mm), whichever is less, from the as-heat-treated edge of the plate.

F.4.4.2.6 Thermal Buffer Pad Requirements. Where the crop is insufficient to obtain test specimens at the proper distance from the heat treated edge of the plate, thermal buffer pads in accordance with ASTM A20 shall be used.

F.4.4.2.7 Marking of Test Specimens. The test specimens shall be marked to ensure positive identification of the lot being tested.

F.4.5 Visual Examination. Each plate shall be examined visually and shall meet the requirements of B.3.6. With respect to coating applications, the number of plates subject to paint film thickness measurements should be held to the minimum necessary to assure continued satisfactory performance. Paint thickness measurements shall be in accordance with Appendix K.

F.4.6 Test Procedures. See [Table F-12](#) and 4.5.

F.4.6.1 Chemical or Spectrographic Analysis. If the sample from the topmost plates fails to meet the requirements, all plates from the heat in question shall be rejected. Samples from rejected plates may be analyzed separately, provided the samples are taken in the specified locations, and those plates which conform in chemical composition to F.3.4 will be accepted.

F.4.6.1.1 Continuous Cast Slabs. The sample selected in accordance with F.4.4.2.3 shall be analyzed to determine conformance to F.3.4. If either sample fails to meet the requirements, all plates from the heat shall be rejected. Plates may be analyzed separately provided the samples are taken in the specified locations, and those plates which conform in chemical composition to F.3.4 will be accepted.

F.4.6.2 Tensile Tests. See 4.5.2 and F.3.5.

F.4.6.3 Impact Tests.

F.4.6.3.1 Charpy V-Notch Impact Test. The specimens shall be tested with coolant temperatures of -120 ± 3 °F (-84 ± 2 °C) and 30 ± 3 °F (-1 ± 2 °C).

F.4.6.3.2 Dynamic Tear Impact Test. The specimens shall be tested with coolant temperatures of -20 ± 3 °F (-29 ± 2 °C) and 30 ± 3 °F (-1 ± 2 °C).

F.4.6.4 Explosion Test. Unless otherwise specified (see F.6.2), the temperature of the plate weldment shall be 30 ± 3 °F (-1 ± 2 °C) for each shot.

F.4.6.5 Gauging and Ultrasonic Soundness Test. Each plate shall be measured with a calibrated micrometer at three evenly distributed points along each longitudinal edge and at two evenly distributed points along each transverse edge. The requirements of T9074-AS-GIB-010/271 shall apply for the qualification of ultrasonic testing personnel, qualification and calibration of equipment, qualification of procedures, and reporting of test results. Ultrasonic soundness tests shall be performed in accordance with ASTM A435, and meet the requirements of supplement S1 therein. Each Type II plate, and, when specified (see F.6.2), all plates, shall be ultrasonically inspected for internal soundness and ultrasonically measured for thickness. Ultrasonic thickness inspection and acceptance shall be in accordance with Appendix J. When plate is specified on a lb/ft² basis, ultrasonic inspection for thickness is not required.

F.5 PACKAGING.

See Chapter 5.

F.6 NOTES.

F.6.1 Intended Use. The HY-130 steel plate covered by this specification is intended for combatant submarine hull use. This steel may also be used in fabricated welded pressure vessels, surface ship construction, or other critical structural applications where an as-welded, notch-tough, high yield strength steel is required. The use of HY-130 steel in fabricated structures or equipment entails much more than a correct material specification, and proper procedures in accordance with the appropriate fabrication documents are required during welding, fabrication, and nondestructive evaluation at the time of use.

F.6.2 Acquisition Requirements. Acquisition documents must specify the following:

- a. Title, number, and date of this specification.
- b. Type of steel plate required (see F.1.2).
- c. If steel plate over ½ inch thick is not required to be classified as Type II (see F.1.2).
- d. Absorbed energy required of subsized specimens (see note 1 of [Table F-3](#)).
- e. Impact properties for nominal plate thicknesses over 6 inches (152 mm) (see note 2 of [Table F-3](#)).
- f. When supplemental Charpy V-notch tests are not required (see note 3 of [Table F-3](#)).
- g. When a copy of the internal soundness inspection report is not required for the contracting activity (see F.3.9).
- h. If an applicable fabrication document is required (see F.3.10).
- i. Sizes and quantity of plate required (see F.3.11.1).
- j. If plate is to be ordered on a lb/ft² basis (see F.3.11.1).
- k. Tighter flatness requirements, when required (see F.3.11.2).
- l. When explosion bulge testing is required for first article testing and whether additional shots and a minimum reduction in thickness are required (see F.3.12).
- m. When descaling and coating are not required (see F.3.13).
- n. Type and thickness of coating required if other than specified (see F.3.13).
- o. If first article test specimens will be located and tested other than as specified on [Figure F-1](#) and [Figure F-2](#) (see F.4.3).
- p. When explosion test temperature is other than specified (see F.4.6.4).
- q. When Type I plates are to be ultrasonically inspected (see F.4.6.5).

F.6.3 First Article. See 6.3.

F.6.4 Receipt Inspection. The plates should be subject to receipt inspection (including chemical composition and mechanical property tests) by consignee to verify conformance to all requirements of the specification. Plates not conforming to the requirements of the specification at any location in the plate may be rejected by the consignee. The plate manufacturer may verify the results of the consignee's receipt inspection. It is the responsibility of the consignee to determine acceptability of the plates for the intended application.

T9074-BD-GIB-010/0300 Rev 2

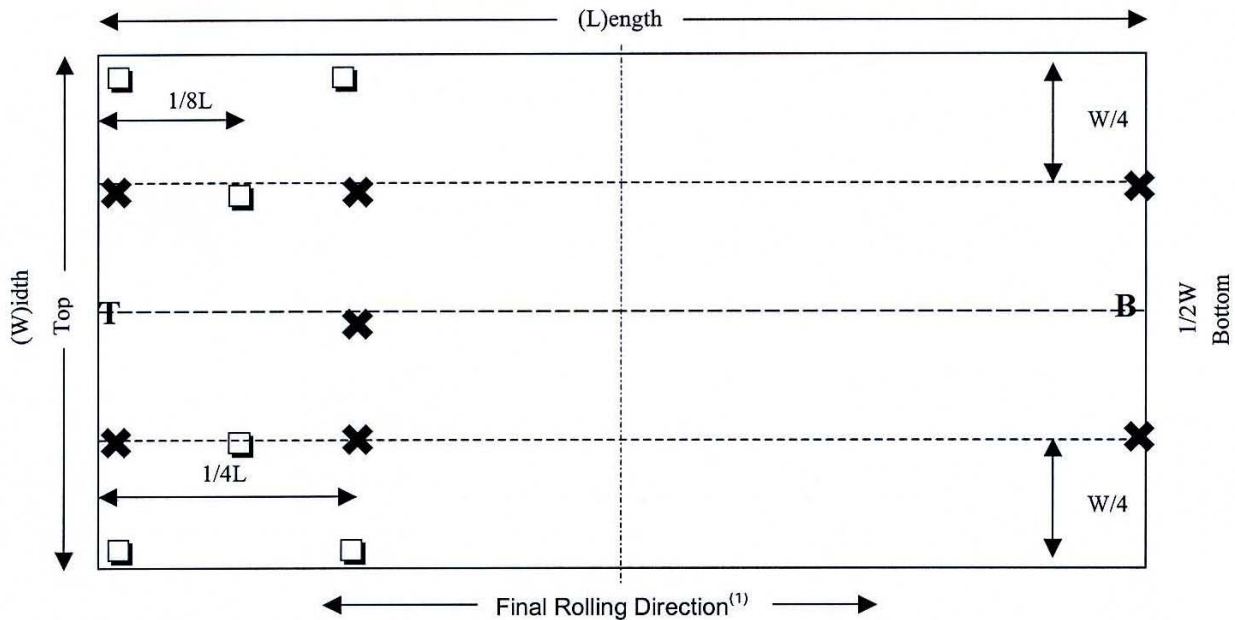

Test	Location Symbol	Comments
Tensile (longitudinal) ⁽²⁾	✕	Surface and mid-thickness depth (1 test at room temperature at each location).
Tensile (transverse) ⁽³⁾	✕	Surface and mid-thickness depth (1 test at room temperature at each location).
Chemical Composition	✕	Full chemistry from all broken transverse tensiles.
Chemical Composition ⁽⁴⁾	□	Full chemistry from surface and mid-thickness location.
CVN (transverse) ⁽²⁾	✕	See F.4.4.2.5 for specimen depth (3 tests at -120 °F and 3 tests at 0 °F, at each location).
5/8 Inch DT (transverse) ⁽²⁾	✕	See F.4.4.2.5 for specimen depth (2 tests at -40 °F and 2 tests at 0 °F, at each location).
CVN Transition Curve ⁽⁵⁾	▲	See F.4.4.2.5 for specimen depth (3 tests at each of the following temperatures: -120 °F, -90 °F, -40 °F, 0 °F, and 30 °F).
5/8 Inch DT Transition Curve ⁽⁵⁾	○	See F.4.4.2.5 for specimen depth (2 tests at each of the following temperatures: -120 °F, -90 °F, -40 °F, 0 °F, and 30 °F).
Multiple Tests	T	Conduct the following tests at this location: ✕, □, ○, ▲
Multiple Tests	B	Conduct the following tests at this location: ✕, □

NOTES:

(1) The final rolling direction is the direction of rolling in which the greatest reduction ratio is achieved. For example, if 25 percent reduction of the initial slab or ingot thickness is achieved by rolling in direction A, and 75 percent reduction of the initial thickness is achieved by rolling in direction B, then direction B is the final rolling direction.

(2) Transverse tensile specimens from top and bottom locations shall be removed from the as-cut edge of the plate, but not closer than 4 inches from the as-heat-treated edge of the plate.

(3) CVN, DT, and longitudinal tensile from the top and bottom locations, shall be removed from material up to 12 inches from the as-cut edge of the plate, but not closer than 4 inches from the as-heat-treated edge of the plate.

(4) Specimens shall be removed from as-cut edge(s) of the plate, but not closer than 4 inches from the as-heat-treated edge of the plate.

(5) Specimens shall be removed from material up to 12 inches, but not closer than 4 inches from the as-heat-treated edge of the plate.

Figure F-1. First Article Inspection Testing (Plate <3 Inches Thick).

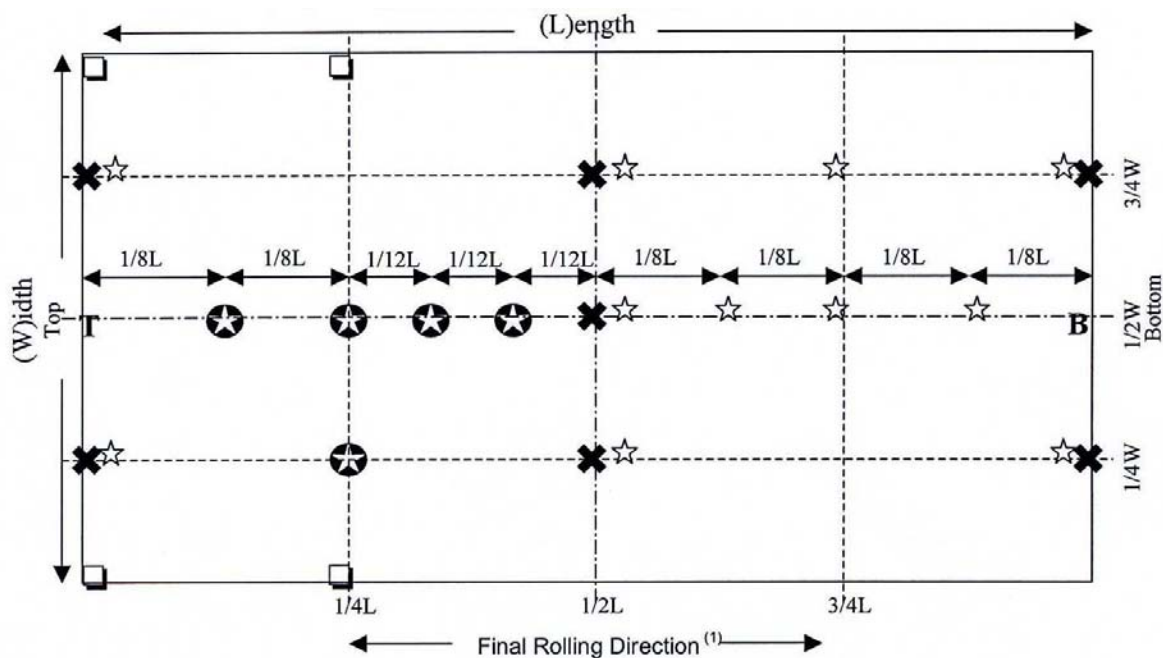

Test	Location Symbol	Comments
Tensile (longitudinal) ⁽²⁾	\times	Surface and mid-thickness depth (1 test at room temperature at each location).
Tensile (transverse) ⁽³⁾	\times	Surface and mid-thickness depth (1 test at room temperature at each location).
Tensile (through thickness) ⁽²⁾	\star	Mid-length of specimen at mid-thickness depth (2 tests at each location).
Chemical Composition	\times	Full chemistry from all broken transverse tensiles.
Chemical Composition and Through Thickness Tensile	\star	Full chemistry from gage length of one broken through thickness tensile.
Chemical Composition ⁽⁴⁾	\square	Full chemistry from surface and mid-thickness location.
CVN (transverse) ⁽²⁾	\times	See F.4.4.2.5 for specimen depth (3 tests at -120°F and 3 tests at 0°F , at each location).
$\frac{5}{8}$ Inch DT (transverse) ⁽²⁾	\times	See F.4.4.2.5 for specimen depth (2 tests at -40°F and 2 tests at 0°F , at each location).
CVN Transition Curve ⁽⁵⁾	\blacktriangle	See F.4.4.2.5 for specimen depth (3 tests at each of the following temperatures: -120°F , -90°F , -40°F , 0°F , and 30°F).
$\frac{5}{8}$ Inch DT Transition Curve ⁽⁵⁾	\circ	See F.4.4.2.5 for specimen depth (2 tests at each of the following temperatures: -120°F , -90°F , -40°F , 0°F , and 30°F).
Multiple Tests	T	Conduct the following tests at this location: \times , \star , \square , \blacktriangle , \circ
Multiple Tests	B	Conduct the following tests at this location: \times , \star , \square

NOTES:

(1) The final rolling direction is the direction of rolling in which the greatest reduction ratio is achieved. For example, if 25 percent reduction of the initial slab or ingot thickness is achieved by rolling in direction A, and 75 percent reduction of the initial thickness is achieved by rolling in direction B, then direction B is the final rolling direction.

(2) Transverse tensile specimens from top and bottom locations shall be removed from the as-cut edge of the plate, but not closer than 4 inches from the as-heat-treated edge of the plate.

(3) Longitudinal tensile, through thickness tensile, $\frac{5}{8}$ inch DT and CVN specimens, from the top and bottom locations, shall be removed from material up to 12 inches from the as-cut edge of the plate, but not closer than 4 inches from the as-heat-treated edge of the plate.

(4) Specimens shall be removed from as-cut edge(s) of the plate, but not closer than 4 inches from as-heat-treated edge of the plate.

(5) Specimens shall be removed from material up to 12 inches, but not closer than 4 inches from the as-heat-treated edge of the plate.

Figure F-2. First Article Inspection Testing (Plate ≥ 3 Inches Thick).

T9074-BD-GIB-010/0300 Rev 2

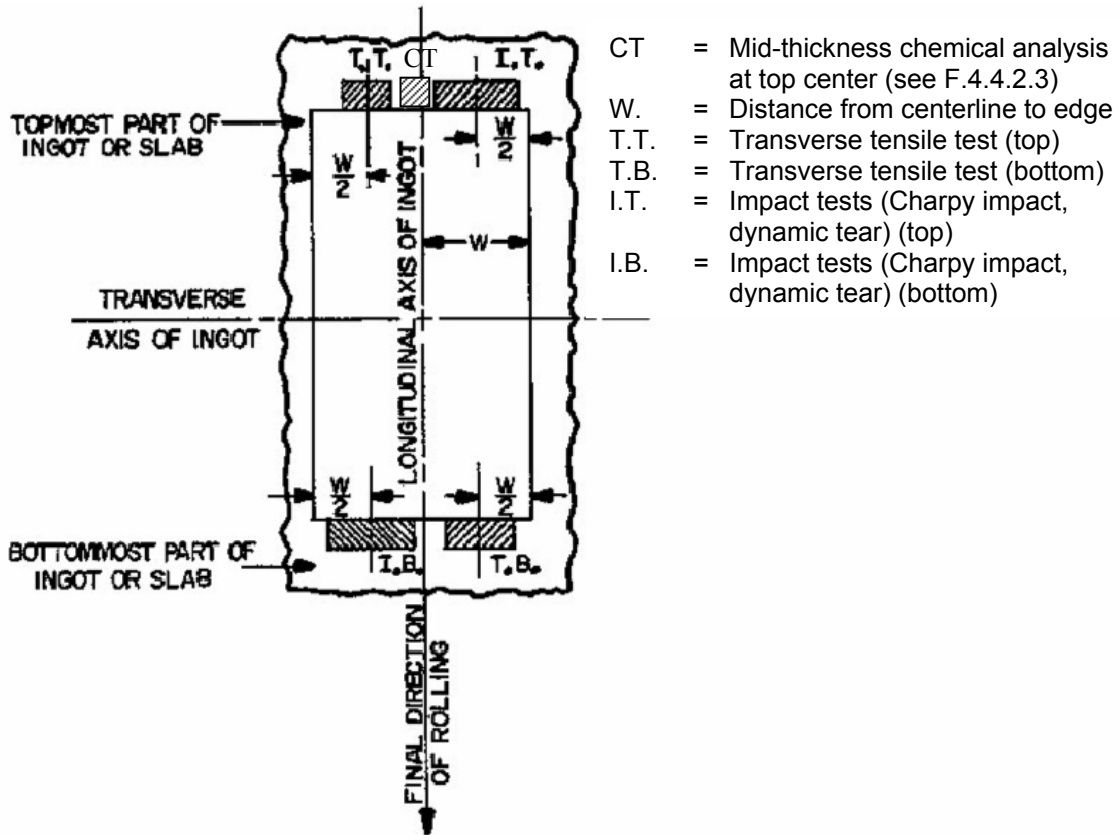

Figure F-3. Method of Locating Test Specimens for Plates as Rolled Directly from Ingots or Slabs with the Final Direction of Rolling Parallel to the Longitudinal Axis of the Ingot.

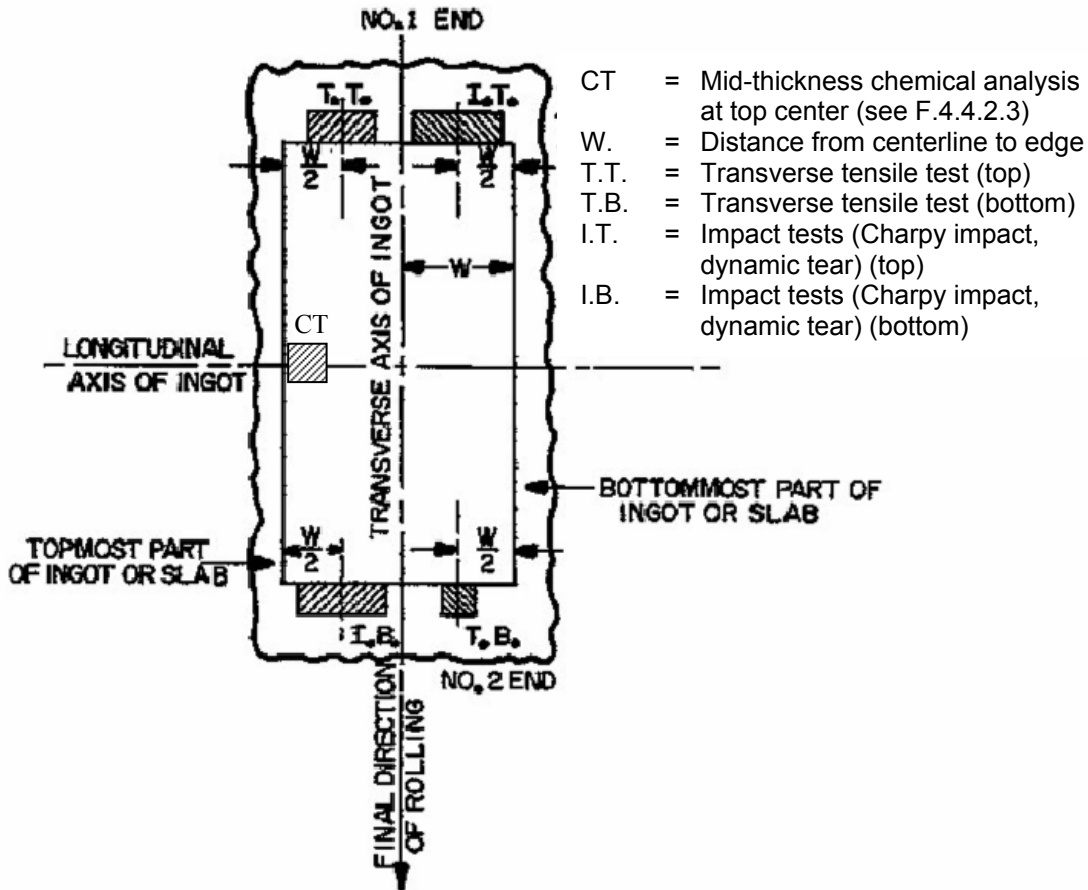

Figure F-4. Method of Locating Test Specimens for Plates as Rolled Directly from Ingots or Slabs with the Final Direction of Rolling Parallel to the Transverse Axis of the Ingot.

T9074-BD-GIB-010/0300 Rev 2

THIS PAGE INTENTIONALLY LEFT BLANK

APPENDIX G (21952) STEEL (HY-80 AND HY-100) BARS, ALLOY

G.1 SCOPE.

G.1.1 Scope. This appendix covers Grade HY-80 and Grade HY-100 alloy steel bars intended primarily for use in the hulls of combat ships and for other critical structural applications where a notch-tough, high-strength material is required.

G.1.2 Classification.

G.1.2.1 Grades. Steel bars shall be of the following grades, as specified (see G.6.2).

Grade HY-80 - 80,000 lb/in² (80 ksi) [552 MPa] tensile yield strength, minimum.

Grade HY-100 - 100,000 lb/in² (100 ksi) [690 MPa] tensile yield strength, minimum.

G.1.2.2 Types. Steel (HY-80 and HY-100) bars shall be furnished in the following types, as specified (see G.6.2).

Type A - Hot rolled, quenched and tempered.

Type B - Hot rolled, quenched and tempered and cleaned (scale free).

G.2 APPLICABLE DOCUMENTS.

See Chapter 2.

G.3 REQUIREMENTS.

G.3.1 Material. The steel shall be vacuum degassed.

T9074-BD-GIB-010/0300 Rev 2

G.3.2 Chemical Composition. The chemical composition heat analysis shall be in accordance with [Table G-1](#).

Table G-1. Chemical Composition (Weight Percent). 1/

Element		Weight Percent (single values are maximums)	
		Grade HY-80	Grade HY-100
Carbon	Heat Analysis	0.10 – 0.18	0.10 – 0.20
	Product Analysis	0.08 – 0.20	0.08 – 0.22
Manganese	Heat Analysis	0.10 – 0.40	
	Product Analysis	0.10 – 0.45	
Phosphorus	Heat & Product	0.015	
Sulfur	Heat Analysis	0.004	
	Product Analysis	0.006	
Silicon 2/	Heat Analysis	0.15 – 0.35	
	Product Analysis	0.12 – 0.38	
Nickel	Heat Analysis	2.50 – 3.25	2.75 – 3.50
	Product Analysis	2.43 – 3.32	2.67 – 3.57
Chromium	Heat Analysis	1.35 – 1.80	
	Product Analysis	1.29 – 1.86	
Molybdenum	Heat Analysis	0.30 – 0.60	
	Product Analysis	0.27 – 0.63	
Vanadium 3/	Heat & Product	0.03	
Titanium 3/	Heat & Product	0.02	
Copper 3/	Heat & Product	0.25	
Arsenic 3/	Heat & Product	0.025	
Tin 3/	Heat & Product	0.030	
Antimony 3/	Heat & Product	0.025	
NOTES:			
1/ For definition of lot for heat analysis, see G.4.4.1.			
2/ When vacuum carbon deoxidation is used, the minimum silicon content may be reduced to 0.08 percent in which case the steel shall be fully killed and shall not be active in the molds during teeming.			
3/ Element shall not be intentionally added.			

G.3.3 Tensile Properties. The material shall meet the tensile property requirements as specified in [Table G-2](#), after all heat treatments including stress relief.

Table G-2. Tensile Property Requirements.

Property		Required Value	
		Grade HY-80	Grade HY-100
Yield strength, 0.2 percent offset, ksi [MPa]		80 – 99.5 [552 – 686]	100 – 120 [690 – 827]
Ultimate tensile strength, ksi		Information only	Information only
Elongation in 2 inches (51 mm) (minimum percent) <u>1/</u>	Longitudinal	20	18
	Transverse <u>2/</u>	18	16
Reduction of area (minimum percent)	Longitudinal	55	50
	Transverse <u>2/</u>	50	45
NOTES:			
<u>1/</u> Only applicable to bar thicknesses $\frac{7}{16}$ inch (11 mm) and over, and round and hexagon diameters $\frac{3}{4}$ inch (19 mm) and over.			
<u>2/</u> Unless otherwise specified (see G.6.2), transverse properties are only required for bars greater than or equal to 4 inches (102 mm) in diameter or thickness used for hull penetration applications.			

G.3.4 Impact Properties. The material shall meet the impact property requirements as specified in [Table G-3](#), after all heat treatments including stress relief.

Table G-3. Impact Property Requirements. 1/

Test (Coolant) Temperature $\pm 3^{\circ}\text{F}$ ($\pm 2^{\circ}\text{C}$)	Charpy V-notch Energy, minimum foot-pounds [joules] <u>2/</u> , <u>4/</u>		Sample Orientation
	Grade HY-80	Grade HY-100	
-120 °F (-84 °C)	50 [68]	50 [68]	Longitudinal
0 °F (-18 °C)	70 [95]	70 [95]	
-120 °F (-84 °C)	50 [68]	50 [68]	Transverse <u>3/</u>
0 °F (-18 °C)	60 [81]	60 [81]	
NOTES:			
<u>1/</u> As an alternative to Charpy V-notch impact testing (transverse and longitudinal directions) of bar with a minimum thickness of $\frac{5}{8}$ inch (16 mm), dynamic tear testing may be substituted at the option of the Contractor when approved by the Command or Agency concerned (see G.6.2). The dynamic tear test specimens shall be of the same orientation to the final direction of bar rolling as the Charpy V-notch specimens they are substituting. The minimum average dynamic tear energy required for the two specimens is 450 ft-lbs [610 J] for HY-80 and 500 ft-lbs [678 J] for HY-100 at a test temperature of minus 40 ± 3 °F (minus 40 ± 2 °C).			
<u>2/</u> No single Charpy V-notch or dynamic tear test value shall be below the minimum average required by more than 5 ft-lbs [7 J] and 25 ft-lbs [34 J], respectively.			
<u>3/</u> Unless otherwise specified (see G.6.2), transverse properties are only required for bars greater than or equal to 4 inches (in diameter) or thicknesses used for hull penetration applications. The notch of the specimen shall be oriented along the radial direction of the bar (see Figure G-1).			
<u>4/</u> For material thicknesses below $\frac{5}{8}$ inch (16 mm) and round and hexagon diameters under $\frac{5}{8}$ inch (16 mm), subsized Charpy V-notch test specimens shall be as provided in ASTM A673. Equivalent absorbed energy requirements for subsized specimens shall be as specified (see G.6.2).			

G.3.5 Heat Treatment. The bars shall be quenched and tempered. The Contractor shall determine the detailed procedure to produce bars meeting the mechanical property requirements with the exception that the tempering temperature shall be not less than the temperature specified in [Table G-4](#). If the bars are stress relieved after final tempering, the stress relief temperature shall be less than the tempering temperature and shall be not less than the temperature specified in [Table G-4](#).

T9074-BD-GIB-010/0300 Rev 2

Bars shall be rapidly cooled by water, aqueous polymer, or forced air quenching after tempering. Rapid cooling shall be employed following stress relief. Heat treatment procedures and documentation shall be in accordance with Chapters 1 through 6 and Appendix B. All bar that constitute the tempering or stress relief furnace load for a batch-type furnace shall be removed from the furnace and rapidly cooled by water quenching at the same time (i.e., the same quench load). The use of more than one quench load for tempering or stress relief heat treatment of a single batch-type furnace load of bar is prohibited. A process shall be put in place to maintain the effectiveness (e.g., flow rate and water capacity) of the quench tank similar to that used during the first article qualification.

Table G-4. Minimum Tempering and Stress Relief Temperatures.

Grade	Minimum Tempering Temperature, degrees	Minimum Stress Relief Temperature, degrees
HY-80	1200 °F (649 °C)	1100 °F (593 °C)
HY-100	1100 °F (593 °C)	1050 °F (566 °C)

G.3.5.1 Simulated Stress Relief. When a simulated stress relief is specified (see G.6.2), samples from the same heat treated lot shall be subject to a simulated stress relief (see G.4.4.2.4). Simulated stress relief specimens shall be sampled and shall be in accordance with G.4.4.2.3. These specimens should be tested for tensile and Charpy V-notch impact properties and meet the requirements of G.3.3 and G.3.4. The fabricator (consignee) shall specify the stress relief thermal cycles (including cooling rates) to the Contractor. Stress relief shall be specified only where necessary to meet machining tolerances.

G.3.6 Surface Quality. The bars shall be free of pipe, cracks, and flakes. Within the limits of good manufacturing practices, the bars shall be free of injurious seams, laps, segregation, or other imperfections which, due to their nature, degree, or extent, will interfere with the use of the material in machining or fabrication of parts. Surface imperfections may be removed by grinding, provided the thickness is not reduced below the minimum thickness permitted, and the ground area gradually tapers into the surrounding metal.

G.3.7 Dimensions and Tolerances. Bars shall conform to the dimensions and tolerances specified in ASTM A29.

G.3.8 Identification Marking. Bars shall be identified with this specification number, Grade HY-80 or HY-100, whichever is applicable, lot number, class, and Contractor's name or trademark, as follows:

G.3.8.1 Type A Bars.

- a. Bars having the following cross-sections shall have the lot number and the designation Grade HY-80 or Grade HY-100, whichever is applicable, indent stamped on one end.

Sizes – Round, hexagon, and square 2½ inches (64 mm) and over. Flats over 2 inches (51 mm) wide and 2 inches (51 mm) thick.

This specification number, the grade, and the Contractor's name or symbol shall be securely affixed to each end of each lift or bundle of bar, or to each bar when shipped loose.

- b. Bars having cross-sections less than the bars specified above shall have the identification markings placed on waterproof tags. At least one tag shall also be securely attached to each end of each lift or bundle, or to each bar when shipped loose.

G.3.8.2 Type B Bars. Type B bars of the following sizes shall be continuously marked with the lot number, Grade HY-80 or HY-100, whichever is applicable, and the Contractor's name or trademark in accordance with FED-STD-183.

Sizes – Rounds ¾ inch (19 mm) and over. Hexagons 7/8 inch (22 mm) across flats and over.

Smaller bars shall be marked as specified for Type A bars, G.3.8.1.b, above.

G.3.9 Descaling and Cleaning. Scale may be removed from Type B bars by abrasive blast, acid pickling, grinding, or machining. Bars shall meet the specified dimensions and tolerance after cleaning. Acid pickling shall be accomplished in accordance with the following:

- a. Rust preventatives, oils, greases, oil paints, and other foreign matter shall be removed prior to immersion in pickling bath. When alkaline solutions are used for this purpose, the bars shall be thoroughly rinsed with water prior to pickling. The final rinse shall be hot water between 160 °F and 200 °F (71 °C and 93 °C).

b. The pickling bath shall consist of the following initial solution:

- (1) Sulfuric acid – 5 to 10 percent by volume. The sulfuric acid concentration shall be maintained at 5 to 10 percent by volume.
- (2) Sodium chloride – 1½ percent by weight (13 pounds per 100 gallons of solution) (5.9 kilograms per 379 liters of solution). Sodium chloride should be added as required to maintain this concentration.
- (3) Inhibitor – as recommended by the Contractor.

When the iron content in the pickling solution exceeds 5 percent of the total weight of the entire bath, the pickling solution shall be discarded and another pickling solution, in accordance with G.3.9, shall be used instead. Methods for calculating iron and acid concentrations shall be in accordance with S9086-VD-STM-000/CH-631.

- c. Pickling bath temperature shall be in the range of 150 °F to 200 °F (66 °C to 93 °C).
- d. Pickling time shall be limited to 2 hours with normal rinsing time. If necessary, up to 4 hours pickling time shall be permitted provided additional rinsing time is employed.
- e. Rinsing shall be carried out in fresh water maintained at a minimum temperature of 170 °F (77 °C). Minimum rinsing time shall be 2 minutes for bars pickled up to 2 hours. Bars pickled over 2 but less than 4 hours shall be rinsed for 20 minutes.
- f. Acid concentration of the rinse water shall not exceed 2 grams per gallon (3.8 liters).
- g. After pickling, the bars shall be allowed to age a minimum of 24 hours before fabricating or welding.

G.3.10 Macrostructure. The quality and cleanliness of bars shall be equal to or better than the following macrographs of ASTM E381. Unacceptable conditions of ASTM E381 also apply.

Cross-Sectional Area	Macrograph Numbers
36 square inches and less	C2, S2, R2
Over 36 square inches	C3, S3, R3

G.3.11 Repair by Welding. Weld repair is not allowed unless specifically approved on a case basis by the Command or Agency concerned.

G.3.12 Explosion Testing. Not required.

G.4 VERIFICATION.

G.4.1 Responsibility for Inspection. See 4.1.

G.4.2 Classification of Inspections. The inspection requirements specified herein are classified as follows:

- a. First article inspection (see G.4.3).
- b. Conformance inspection (see G.4.4).

G.4.3 First Article Inspection. First article inspection shall consist of testing the samples specified in G.4.3.1 in accordance with the procedures of G.4.5 and G.4.6 (see 4.3 and 6.3). A first article inspection report shall be prepared as specified in 3.1.

G.4.3.1 Sampling for First Article Inspection. As a minimum, the thickest or largest diameter bars, whichever are greater, to be produced at the mill shall be tested.

G.4.4 Conformance Inspection. Conformance inspection (i.e., inspections of production lots) shall consist of the examinations of G.4.5 and the tests of G.4.6.

G.4.4.1 Lot Definitions.

G.4.4.1.1 Lot for Chemical Composition. See 4.4.1.1.

G.4.4.1.2 Lot for Macroetch Tests. Each heat of steel shall constitute a lot.

G.4.4.1.3 Lot for Tension and Impact Tests. All bars of the same nominal size from the same chemical composition lot, and heat treated in the same furnace charges or continuously tempered under the same conditions of time and temperature shall constitute a lot.

T9074-BD-GIB-010/0300 Rev 2

G.4.4.1.4 Lot for Dimensional and Surface Examination. A lot shall consist of all bars of the same type and size offered for inspection at one time.

G.4.4.2 Sampling for Conformance Inspection.

G.4.4.2.1 Sampling for Chemical or Spectrographic Analysis. Samples for chemical analysis shall be taken from the top bar of each of two ingots or continuous castings in each lot. Solid samples may be taken for spectrographic analysis from the same locations as above.

G.4.4.2.2 Sampling for Macroetch Test. Samples for macroetch test shall be taken from each lot in accordance with method A or B below.

- Method A - Where the product of the heat is identified by original position in the ingot, samples shall be taken from the top of the first and bottom of the last useable bar produced from the first, middle, and last useable ingots.
- Method B - Where the product of the heat is not identified with respect to position in ingot or continuous cast, the inspection lot shall consist of all bars of the same nominal size and heat. From each lot, samples for macroetch test shall be taken from one end of bars selected at random in accordance with [Table G-5](#).

G.4.4.2.2.1 Partial Heats. Where less than one half of a heat is applied, macroetch tests may be taken from the first and last ingot applied, in lieu of the first, middle, and last useable ingot.

Table G-5. Sampling for Macroetch Tests.

Number of Bars in Lot	Number of Bars Selected for Macroetch Test
3 to 8	3
9 to 15	4
16 to 25	5
26 to 40	7
41 to 65	10
66 to 110	15

G.4.4.2.3 Sampling for Mechanical Tests. Longitudinal tension and Charpy V-notch test specimens shall be machined as follows:

- For bars up to 4 inches (102 mm) in diameter or thickness, centerline of tests shall correspond with centerline of the bar. The midpoint of the tensile specimens and the closest ends of the impact specimens shall be located a minimum of the diameter or thickness of the bar from the end of the bar.
- For bars over 4 inches (102 mm) in diameter or thickness, centerline of test specimens shall correspond to $\frac{1}{4}$ diameter or thickness of bar or 2 inches (51 mm) below the surface, whichever is greater. The midpoint of the tensile specimens and the closest ends of the impact specimens shall be located a minimum of the diameter or thickness of the bar or 6 inches (152 mm), whichever is less from the end of the bar.

When specified (see G.6.2), transverse tension and impact specimens shall be machined from bars. For bars 4 inches (102 mm) and greater in diameter, specimens shall be located at D/4 or 2 inches (51 mm), whichever is greater, below the surface, as illustrated on [Figure G-1](#). The midpoint of the tensile specimens and the closest sides of the impact specimens shall be located a minimum of the diameter or thickness of the bar or 6 inches (152 mm), whichever is less, from the end of the bar. For bars less than 4 inches (102 mm) in diameter, transverse specimens shall be as specified (see G.6.2).

G.4.4.2.3.1 Tension Test Specimens. Specimens for the tension test shall be taken from a lot, on the basis of one specimen for each 5 tons (4.5 metric tons) or fraction thereof. Each specimen shall be taken from a different bar and not less than 2 specimens shall be selected from any lot.

G.4.4.2.3.2 Charpy V-Notch Test Specimen. Samples for Charpy V-notch tests shall be selected from a lot on the basis of one sample for each 5 tons (4.5 metric ton) or fraction thereof. Each sample shall be of a size sufficient to allow preparation of at least six Charpy V-notch test specimens.

G.4.4.2.3.3 Dynamic Tear Test Specimen. For dynamic tear testing, one set (two specimens) per each 5 tons (4.5 metric tons) or fraction thereof is required.

G.4.4.2.3.4 Marking of Test Specimens. The test specimens shall be marked to ensure positive identification of the lot being tested.

G.4.4.2.4 Sampling for Mechanical Properties Following Simulated Stress Relief. When specified (see G.6.2), sample material (see G.4.4.2) shall be subjected to simulated stress relief operations after quenching and tempering, but prior to testing for conformance to the mechanical property requirements in G.3.3 and G.3.4. The sample material shall not be removed from the parent material prior to quenching and tempering. The total time at temperature and cooling rate for the simulated stress relief operations shall be as specified (see G.6.2).

G.4.5 Examination.

G.4.5.1 Dimensional Examination. Bars from each lot shall be selected at random and measured for conformance to the requirements of G.3.7. The number of bars selected shall be the same as the number selected for macroetch testing (see [Table G-5](#)).

G.4.5.2 Visual Examination Prior to Packaging. Each length of bar shall be visually examined for surface condition and finish in accordance with G.3.6 and G.3.8. Any bar not meeting these requirements shall be reworked or rejected. Packaging shall conform to the requirements of G.5. Deficiencies shall be corrected prior to shipment.

G.4.5.3 Nondestructive Examination. The requirements of T9074-AS-GIB-010/271 shall apply for the qualification of inspection personnel, equipment, procedures, and reporting of test except as modified herein.

G.4.5.3.1 Ultrasonic Examination. Each bar shall be examined in accordance with T9074-AS-GIB-010/271. Any discontinuity whose reflection produces a signal equal to or greater than the response from the reference calibration hole or causes a complete loss of back reflection shall be cause for rejection of the bar.

G.4.6 Methods of Inspection.

G.4.6.1 Chemical or Spectrographic Analysis. If any analysis fails to conform to G.3.2, the lot represented by that analysis shall be rejected. When both heat and product analyses are determined, the product analysis shall be used to determine acceptance or rejection.

G.4.6.2 Charpy V-Notch Impact Test. The specimens shall be tested with coolant temperature of minus 120±3 °F (minus 84±2 °C) and 0±3 °F (minus 18±2 °C). For first article inspection, transition curves (transverse, when possible, and longitudinal to the direction of rolling) shall be taken with data points at each temperature of minus 120 °F (minus 84 °C), minus 90 °F (minus 68 °C), minus 40 °F (minus 40 °C), 0 °F (minus 18 °C), and room temperature. A minimum of five specimens for each point are required, and all individual values shall be reported.

G.4.6.3 Macrostructure. Samples selected in accordance with G.4.4.2.2 shall be prepared and examined in accordance with ASTM E381. Approximately half the samples shall be cut to reveal a transverse surface. The remainder of the samples shall be cut to reveal a longitudinal surface.

G.4.7 Macroetch Tests. Where macroetch tests are not as specified in G.4.4.2.2, appropriate discard shall be made until sound metal is obtained. In such instances the product from the tops and bottoms of the ingots in the lot shall be subjected to macroscopic etch test and appropriate discard made until sound metal is reached. Where the material is not identified with respect to original position in the ingot, and one or more macroetch tests do not conform to G.4.4.2.2, all bars in the lot shall be subjected to macroetch test on each end.

G.5 PACKAGING.

See Chapter 5.

G.6 NOTES.

G.6.1 Intended Use. Grade HY-80 and Grade HY-100 alloy steel bars are intended primarily for use in the hulls of combatant ships and for other critical structural applications where a notch-tough, weldable high-strength material is required. The use of these steels in fabricated structures or equipment entails much more than materials specification and caution is advised in the areas of welding, fabrication, and nondestructive testing.

G.6.2 Acquisition Requirements. Acquisition documents must specify the following:

- a. Title, number, and date of this specification.
- b. Type and grade required (see G.1.2, G.1.2.1, and G.1.2.2).
- c. Sizes and quantity of bars required.
- d. Whether transverse mechanical properties are required (see note 2 of [Table G-2](#), note 3 of [Table G-3](#), and G.4.4.2.3).

T9074-BD-GIB-010/0300 Rev 2

- e. Transverse properties of bars less than 4 inches in diameter (see G.4.4.2.3).
- f. Whether dynamic tear test impact criteria are to be the sole requirements for bars (see note 1 of [Table G-3](#)).
- g. Absorbed energy requirements of subsize specimens (see note 4 of [Table G-3](#)).
- h. When a simulated stress relief sample is required. If required, the number of thermal cycles, the heating and cooling rates, and time at temperature shall be specified (see G.3.5.1 and G.4.4.2.4).

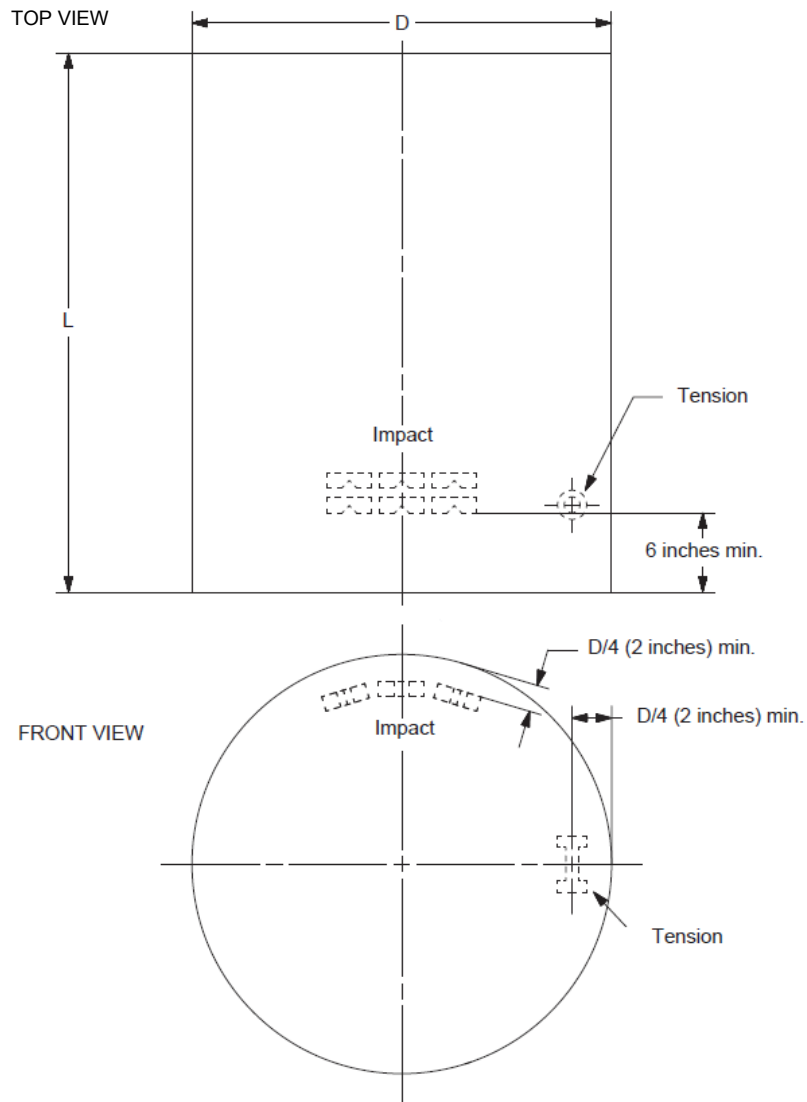

Figure G-1. Typical Schematic Diagram of Transverse Test Specimen Location on an 8-Inch Diameter Bar.
The location of the test specimens shall be $D/4$ or 2 inches below the heat treated surface, whichever is greater.
(see G.4.4.2.3)

T9074-BD-GIB-010/0300 Rev 2

THIS PAGE INTENTIONALLY LEFT BLANK

APPENDIX H (22664) STEEL, STRUCTURAL SHAPES ALLOY, HIGH YIELD STRENGTH (HY-80 AND HY-100)

H.1 SCOPE.

H.1.1 Scope. This appendix covers Grade HY-80 and Grade HY-100 alloy steel rolled and extruded shapes for use in applications where good weldability and notch toughness are required.

H.2 APPLICABLE DOCUMENTS.

See Chapter 2.

H.3 REQUIREMENTS.

H.3.1 Chemical Composition. The chemical composition, heat and product, shall be as specified in [Table H-1](#).

Table H-1. Chemical Composition (Weight Percent). 1/

Element		Weight Percent (single values are maximums)	
		Grade HY-80	Grade HY-100
Carbon	Heat Analysis	0.18	0.20
	Product Analysis	0.20	0.22
Manganese	Heat Analysis	0.10 – 0.40	
	Product Analysis	0.10 – 0.45	
Phosphorus <u>2/</u>	Heat & Product	0.015	
Sulfur <u>2/</u>	Heat & Product	0.010	
Silicon <u>3/</u>	Heat Analysis	0.15 – 0.35	
	Product Analysis	0.12 – 0.38	
Nickel	Heat Analysis	2.00 – 3.25	2.25 – 3.50
	Product Analysis	1.93 – 3.32	2.18 – 3.57
Chromium	Heat Analysis	1.00 – 1.80	
	Product Analysis	0.94 – 1.86	
Molybdenum	Heat Analysis	0.20 – 0.60	
	Product Analysis	0.17 – 0.63	
Vanadium <u>4/</u>	Heat & Product	0.03	
Titanium <u>4/</u>	Heat & Product	0.02	
Copper <u>4/</u>	Heat & Product	0.25	
Arsenic <u>4/</u>	Heat & Product	0.025	
Tin <u>4/</u>	Heat & Product	0.030	
Antimony <u>4/</u>	Heat & Product	0.025	
NOTES:			
<u>1/</u> For definition of lot for heat analysis see 4.4.1.1.			
<u>2/</u> Phosphorus and sulfur together shall be not more than 0.023 percent.			
<u>3/</u> When vacuum carbon deoxidation is used, the minimum silicon content may be reduced to 0.08 percent, in which case the steel shall be fully killed and shall not be active in the molds during teeming.			
<u>4/</u> Element shall not be intentionally added.			

T9074-BD-GIB-010/0300 Rev 2

H.3.2 **Tensile Properties.** The material shall meet the tensile property requirements, as specified in [Table H-2](#), after all heat treatments including stress relief.

Table H-2. Tensile Property Requirements.

Property		Required Value	
		Grade HY-80	Grade HY-100
Yield strength, 0.2 percent offset, ksi [Mpa] (longitudinal and transverse)		80 – 100 [552 – 690]	100 – 120 [690 – 897]
Ultimate tensile strength, ksi		<u>1/</u>	<u>1/</u>
Elongation in 2 inches (51 mm) (minimum percent)	Longitudinal	20.0	18.0
	Transverse	15.0	14.0
Reduction of area (minimum percent) <u>2/</u>	Longitudinal	60.0	55.0
	Transverse	45.0	40.0
NOTES:			
<u>1/</u> Unless otherwise specified (see H.6.2), to be recorded for information only.			
<u>2/</u> Not required for section thicknesses less than ½ inch (13 mm).			

H.3.3 **Impact Properties.** The material shall meet the impact property requirements, as specified in [Table H-3](#), after all heat treatments including stress relief.

Table H-3. Impact Requirements, Charpy V-Notch.

Test (Coolant) Temperature ±3 °F (±2 °C)	Energy, foot-pounds [joules], minimum <u>1/</u>	Shear Fracture, percent, minimum <u>2/</u>	Section Thickness, inches (mm) <u>3/</u>
-120 °F (-84 °C)	70 [95]	50	½ to 2 (13 to 51), inclusive
0 °F (-18 °C)	90 [122]	90	
-120 °F (-84 °C)	60 [81]	50	Over 2 (51)
0 °F (-18 °C)	80 [109]	90	
NOTES:			
<u>1/</u> Average of three tests. No individual test result shall be more than 5 ft-lbs (6.8 joules) below the minimum specified for the average.			
<u>2/</u> Measurement required on each Charpy V-notch specimen. No individual result shall be lower than the minimum. ASTM A370 shall be used for the method of determining percent shear/fibrous fracture.			
<u>3/</u> Tests are not required for shapes less than ¼ inch (6.4 mm) thick and only when specified for shapes ¼ inch (6.4 mm) up to ½ inch (13 mm), in which case acceptance criteria shall be supplied (see H.6.2).			

H.3.4 **Heat Treatment.** Shapes shall meet the requirements of this section with the following restrictions:

- The shapes shall be quenched and tempered. When necessary to achieve mechanical properties, double tempering is permitted and the restrictions for single tempering shall apply to double tempering. The tempering temperature shall be not less than 1175 °F (635 °C) for Grade HY-80 and not less than 1125 °F (607 °C) for Grade HY-100. After tempering, the shapes shall be removed from the furnace and rapidly cooled by water quenching or forced air cooling.
- If the shapes are stress relieved after final tempering, the stress relief temperature shall be at least 100 °F (56 °C) below the tempering temperature and shall be not less than 1100 °F (593 °C) for Grade HY-80 and not less than 1050 °F (566 °C) for Grade HY-100.
- The heat treatment given to each shape shall produce the minimum mechanical properties throughout the shape.
- Heat treatment procedures and documentation shall be in accordance with Chapters 1 through 6 and Appendix B.

H.3.5 Surface Quality. Imperfections such as surface tears, scores, seams, scabs, blisters, laps, excessive scale, and slivers shall be repaired by surface conditioning or welding.

H.3.5.1 Surface Conditioning. Material may be conditioned to remove injurious surface defects by grinding. The ground areas shall be smooth, well blended into the surrounding surface, and the depth shall not be more than permitted by the specified minimum tolerance or $\frac{1}{16}$ inch (1.5 mm) per inch (including fraction) of dimension concerned, whichever is less. The width of conditioning shall be at least three times its depth and gradually tapered into the defect. Deeper defects may be repaired in accordance with H.3.5.2.

H.3.5.2 Weld Repairs. Surface imperfections that are over the specified depth in H.3.5.1 for conditioning may be repaired by chipping or grinding the area to sound metal and, after the forming operations but prior to heat treating, depositing weld metal from a heat treatable electrode in accordance with an approved procedure. The total of the chipped and ground areas of any piece shall not exceed 2 percent of the total area of the piece. The weld metal shall be ground flush with the surface. Weld repair after heat treating is prohibited. The depth of the repaired area shall not exceed the following:

Material Thickness, inches (mm)	Maximum Depth of Defect, inches (mm)
Over $\frac{3}{8}$ – $\frac{1}{2}$ (10 – 13), inclusive	$\frac{1}{16}$ (1.5)
Over $\frac{1}{2}$ – 1 (13 – 25), inclusive	$\frac{1}{8}$ (3)
Over 1 – $1\frac{1}{4}$ (25 – 32) inclusive	$\frac{3}{16}$ (5)
Over $1\frac{1}{4}$ – $2\frac{1}{4}$ (32 – 57), inclusive	$\frac{1}{4}$ (6)
Over $2\frac{1}{4}$ – $3\frac{1}{2}$ (57 – 89), inclusive	$\frac{3}{8}$ (10)
Over $3\frac{1}{2}$ (89), inclusive	$\frac{1}{2}$ (13)

The procedure for weld repair and inspection shall be prepared in accordance with T9074-AD-GIB-010/1688, or the applicable fabrication document. The applicable fabrication document shall be specified (see H.6.2). The weld-repaired area shall be volumetrically inspected in accordance with the requirements for a weld repair in the fabrication document.

H.3.5.3 Macrostructure. The macrostructure shall be determined. Deep acid-etched shapes shall be equal to or better than S-3, R-2, and C-3 plates of ASTM E381.

H.3.5.4 Billets. Unless otherwise specified (see H.6.2), billets shall not be weld-repaired before forming.

H.3.6 Dimensions and Tolerances. The dimensions for structural shapes shall be as shown on the applicable drawings. Except for structural tees, the tolerances shall be as specified (see H.6.2). The tolerances for structural tees shall be as specified on [Figure H-1](#).

H.3.7 Surface Treatment. Unless otherwise specified (see H.6.2), the surfaces of the shapes shall be descaled and coated as specified in Appendix K of this specification.

H.3.8 Internal Soundness. Each shape $\frac{1}{2}$ inch (13 mm) and over in cross-section shall be ultrasonically inspected for freedom from internal defects throughout its entire volume in accordance with T9074-AS-GIB-010/271. The following shall be the accept/reject criteria:

- a. Discontinuities resulting in 75 percent or greater loss of back reflection shall be cause for rejection.
- b. Discontinuities resulting in 50 percent to less than 75 percent loss in back reflection shall be recorded. Two or more discontinuities occurring in the same plane and within 6 inches (152 mm) of each other shall be cause for rejection, providing the indicated area of one or more of the discontinuities is $\frac{3}{4}$ inch (19 mm) or larger.

H.3.9 Identification Marking. Each shape, in the length in which it is shipped, shall have indent stamped on one end the following:

- a. Heat number.
- b. Slab/extrusion number, if applicable.
- c. HY-80 or HY-100, as applicable.
- d. The Contractor's name or trademark.

H.3.10 Workmanship. Shapes shall be uniform in quality and condition and free from visual defects.

H.3.11 Explosion Testing. Not required.

T9074-BD-GIB-010/0300 Rev 2**H.4 VERIFICATION.**

H.4.1 Responsibility for Inspection. See 4.1.

H.4.2 Classification of Inspections. The inspection requirements specified herein are classified as follows:

- a. First article inspection (see H.4.3).
- b. Conformance inspection (see H.4.4).

H.4.3 First Article Inspection. First article inspection shall consist of testing the samples specified in H.4.3.1 in accordance with the procedures in H.4.5 (see 4.3 and 6.3). A first article inspection report shall be prepared as specified in 3.1.

H.4.3.1 Sampling for First Article Inspection. As a minimum, the thickest rolled or extruded structural shapes to be produced at the mill shall be tested.

H.4.4 Conformance Inspection. Conformance inspection (i.e., inspections of production lots) shall consist of the examinations and the tests specified in H.4.6.

H.4.4.1 Lot Definitions.

H.4.4.1.1 Lot for Chemical Composition. See 4.4.1.1.

H.4.4.1.2 Lot Size for Mechanical Tests. Each shape from one heat, heat treated in the same furnace and of the same nominal shape, at the same time, shall constitute a lot.

H.4.4.1.3 Lot Size for Visual and Dimensional Examination and Ultrasonic Inspection. For purposes of visual and dimensional examination, and for ultrasonic inspection, each shape, as submitted for final inspection, shall constitute a lot.

H.4.4.2 Sampling for Conformance Testing.

H.4.4.2.1 Sampling for Chemical or Spectrographic Analysis. Two specimens shall be taken from each lot for chemical analysis. The specimens shall be taken at random and shall be of a size sufficient to obtain 2 ounces (each) of clean fine millings, drillings, or chips, in accordance with ASTM A751. Solid samples shall be taken in lieu of chips when the analysis is made by the spectrographic method.

H.4.4.2.2 Sampling for Mechanical Tests. From each end of an as-heat-treated shape in a lot, at least one specimen for longitudinal tension testing, one specimen for transverse tension testing, and six specimens for longitudinal Charpy V-notch impact testing shall be taken. Brinell hardness readings shall be taken on each end on all the shapes in a lot. The Brinell hardness shall be within 20 Brinell of the average hardness reported for the shapes which were tested for mechanical properties in the lot. For structural tee shapes the specimens shall be taken from each end in the locations specified on [Figure H-2](#). For other shapes, the samples shall be taken from each end in locations specified on the applicable drawings. The following rules shall be used for specifying the locations of samples for mechanical tests:

- a. Specimens for the longitudinal tension test shall be taken from the thickest section of the shape, preferably that section which has received the least hot work.
- b. Specimens for the transverse tension test shall be taken from the thinnest section of the shape.
- c. Specimens for the longitudinal Charpy V-notch test shall be taken from the thickest section of the shape, preferably that section which has received the least hot work.
- d. Charpy V-notch specimens shall be orientated such that the notch is through the thickness of the section (perpendicular to rolled/extruded surfaces) and the bottom of the notch is towards the interior of the shape.
- e. All test specimens shall be taken at a depth of T/2 inches from the heat treated surface for T up to 4 inches (102 mm) inclusive, and T/4 or 2 inches (51 mm), whichever is greater, for T greater than 4 inches (102 mm) where T is defined as the "as quenched" thickness of the thickest section of the shape.
- f. For shapes containing wide flanges or webs, the specimens shall be taken from within the center third of the width. However, where there is a junction of a thick and thin section, such as occurs in a beam or tee, select the specimen at or near the junction and in the thickest section (see [Figure H-2](#)).
- g. The test specimens shall be located at least 2 inches (51 mm) away from the as-heat-treated end or any gas-cut or cold sheared edge, and by not less than the thickest section thickness in the shape from any as-heat-treated edge of the shape.

H.4.4.2.2.1 Form and Dimensions of Mechanical Test Specimens. The form and dimensions of all mechanical test specimens for this specification shall be as follows:

- a. Tension test specimens shall conform to the requirements of ASTM E8.
- b. Charpy V-notch specimens shall be in accordance with ASTM E23 for a 10 by 10 millimeter test.

H.4.5 First Article Inspection. Manufacturers who have not previously produced extrusions or rolled shapes under this specification of the strength level specified shall demonstrate to the Command or Agency concerned that their facilities are capable of quality production of structural shapes. First article inspection shall consist of the examination and tests specified in H.4.7, H.4.8, and H.4.9, and Charpy V-notch transition curves (longitudinal and transverse) with a minimum of five data points at -120 °F (-84 °C), -60 °F (-51 °C), 0 °F (-18 °C), +32 °F (0 °C), and ambient temperature. A minimum of five specimens for each point is required and all individual values shall be reported.

H.4.6 Conformance Inspection. Conformance inspection (i.e., inspections of production lots) shall consist of the examinations and tests specified in H.4.7, H.4.8, and H.4.9.

H.4.7 Visual and Dimensional Examination. Each shape, as prepared for shipment, shall be examined for conformance to the applicable dimensions and shall be visually examined for conformance to H.3.5, H.3.7, H.3.9, and H.3.10, as applicable.

H.4.8 Ultrasonic Inspection. Ultrasonic inspection shall be in accordance with T9074-AS-GIB-010/271, employing a 2¼-MHz transducer from ¾ to 1½ inches (19 to 29 mm) in diameter.

H.4.9 Methods of Inspection.

H.4.9.1 Chemical or Spectrographic Analysis. The samples selected in H.4.4.2.1 shall be individually analyzed for conformance to H.3.1.

H.4.9.2 Tension Test. Specimens selected and prepared in accordance with H.4.4.2.2 shall be tested as specified in ASTM E8 for conformance to H.3.2. The location of the center of the specimen gauge length shall be at least equal to the section width divided by two from any as-heat-treated edge.

H.4.9.3 Charpy V-Notch Impact Test. The Charpy V-notch impact test selected in accordance with H.4.4.2.2 shall be performed in accordance with ASTM E23 and shall meet the requirements of H.3.3.

H.4.9.4 Macroetch Test. Two ends of the as-heat-treated shapes that represent the two ends of the billet shall be tested in accordance with macroetch test of ASTM E381.

H.4.10 Reheat Treatment Provisions. Unless otherwise specified (see H.6.2), extrusions may not be reheat treated more than twice.

H.4.11 Heat Treatment Test Report. A record of heat treatment shall be prepared (see 3.5.)

H.5 PACKAGING.

See Chapter 5.

H.6 NOTES.

H.6.1 Intended Use. Grade HY-80 and HY-100 alloy steel structural shapes are intended primarily for critical structural applications where a notch-tough, high-strength material is required.

H.6.2 Acquisition Requirements. Acquisition documents must specify the following:

- a. Title, number, and date of this specification.
- b. When minimum tensile strength is required and, if so, specify acceptance criteria (see [Table H-2](#)).
- c. If impact tests for sub-size specimens are required and, if so, specify acceptance criteria (see [Table H-3](#)).
- d. Applicable fabrication document (see H.3.5.2).
- e. If billets can be weld repaired before forming (see H.3.5.4).
- f. Tolerances of other than structural tees (see H.3.6).
- g. If descaling and coating are to be other than as specified in Appendix K (see H.3.7).
- h. The number of times extrusions may be reheat treated (see H.4.10).

T9074-BD-GIB-010/0300 Rev 2

- i. Number of pieces required and estimated piece weight.
- j. Applicable drawing number with specific dimensions and tolerances for shapes, and location of test specimens as appropriate.

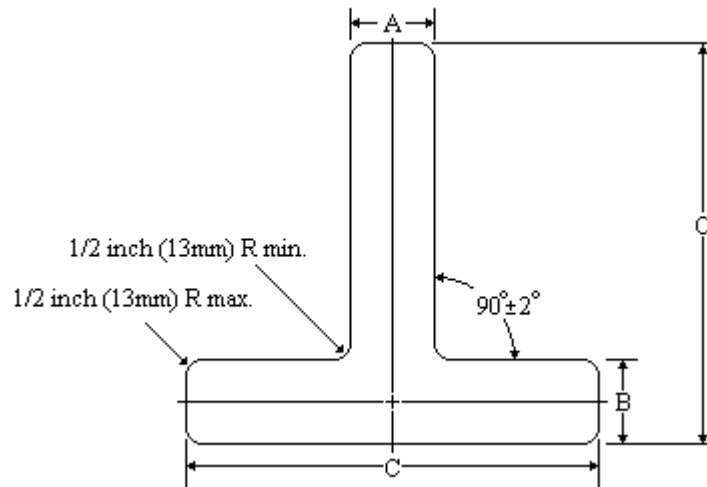

Web offcenter $\pm \frac{3}{32}$ inch (2.4 mm)

Camber/Sweep = $\frac{1}{8}$ inch x (total length of extrusion [feet]) / 5

Camber/Sweep = 3 mm x (total length of extrusion [meters]) / 1.524

Flange/Web squareness = 2 degrees maximum

	A Web Thickness, <u>2/</u> inches (mm), minimum		B Flange Thickness, <u>2/</u> inches (mm), minimum			C Flange Width or Depth of Section (Total), inches (mm)		Length, inches (mm)
	0 – 0.875 (0 – 22), inclusive	Over 0.875 to 1.500, (22 – 38), inclusive	Over 0.875 to 1.500, (22 – 38), inclusive	Over 1.500 to 2.000, (38 – 51), inclusive	Over 2.000 to 2.500, (51 – 63), inclusive	0 to 5, (0 – 127), inclusive	Over 5 to 15, (127 – 381), inclusive	
Tolerances, <u>1/</u> inches (mm)	0.025 (0.6)	0.035 (0.9)	0.029 (0.8)	0.035 (0.9)	0.050 (1.3)	$\frac{1}{16}$ (1.5)	$\frac{1}{8}$ (3)	$\frac{1}{4}$ (6)

NOTES:

1/ Over gauge shall be such that the average weight per linear foot (or meter) of any structural tee shall not exceed the ordered dimensional weight by more than 3 percent.

2/ The thickness of the web and the flange shall be measured at a point not less than 1 inch (25 mm) in from the edge.

Figure H-1. Dimensional Tolerances and Nomenclature for Structural Tee Extrusions.

T9074-BD-GIB-010/0300 Rev 2

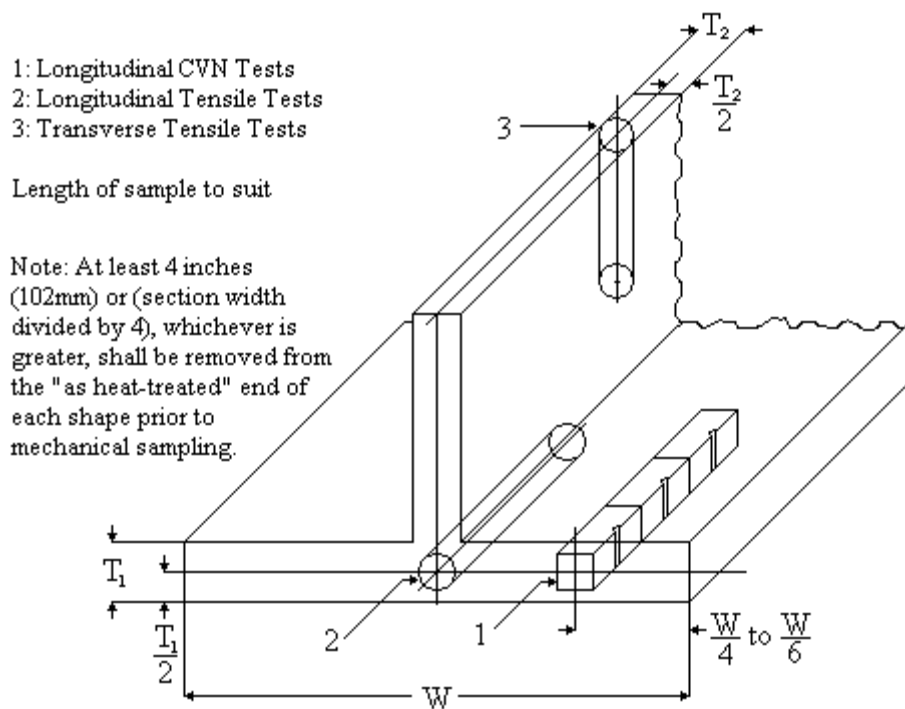

Figure H-2. Location of Mechanical Test Coupons for Structural Tee.

APPENDIX I (24451)

STEEL HEAT TREATED HEADS, ALLOY STRUCTURAL, HIGH YIELD STRENGTH (HY-80 AND HY-100)

I.1 SCOPE.

I.1.1 Scope. This appendix covers HY-80 and HY-100 hot formed, heat treated heads. The requirements for HY-80 apply to thicknesses up to 8 inches (203 mm), inclusive, and HY-100 to thicknesses up to 3 inches (76 mm), inclusive. Two-piece heads consist of heads made from two flat plates welded together and then formed as one piece.

I.2 APPLICABLE DOCUMENTS.

See Chapter 2.

I.3 REQUIREMENTS.

I.3.1 Material. Base metal material composition for heads shall be in accordance with Appendix B, Grade HY-80 or HY-100, as specified (see I.6.2). The material from which the heads are produced shall be from a source that has met the first article testing requirements of Appendix B.

I.3.2 Two-Piece Heads (Weldments). Welds in two-piece heads shall meet all of the requirements as specified in the applicable fabrication document (see I.6.2) following all forming, heat treatment, and resizing treatments. Two-piece heads shall be joined with a heat treatable filler material. Unless otherwise specified (see I.6.2), two-piece heads shall be joined by qualified welders and weld procedures approved in accordance with S9074-AQ-GIB-010/248.

I.3.3 Mechanical Properties. Test specimens shall be taken after the final tempering and resizing treatments, and shall meet the tensile and impact requirements in accordance with Appendix B.

I.3.3.1 Two-Piece Heads. Transverse weldment tensile and impact specimens shall meet the requirements of T9074-BC-GIB-010/0200 for HY-80 and HY-100, following all forming, heat treatment, and resizing treatments.

I.3.4 Resizing. If resizing for ovality or mean diameter is required after the final tempering treatment, it shall be carried out in accordance with the cold forming requirements as specified in T9074-AD-GIB-010/1688 or, when specified, the applicable fabrication document (see I.6.2). The maximum cold forming temperature shall not exceed 500 °F (260 °C). Mechanical testing of heads shall be performed following resizing.

I.3.4.1 Resizing by Warm Forming. The Contractor will be allowed to resize the head by warm forming within the following limitations:

- a. The resizing temperatures shall be at least 50 °F (28 °C) below the tempering temperature and shall be above 1100 °F (593 °C) for HY-80 and 1050 °F (566 °C) for HY-100.
- b. The head shall be rapidly cooled after resizing.
- c. The mean diameter of the head shall not be changed more than 2 inches (51 mm) or 1 percent, whichever is less.
- d. A complete set of mechanical tests shall be performed after resizing.

I.3.5 Heat Treatment. The Contractor is responsible for determining the detailed procedure to be used to produce heads meeting the mechanical requirements of this specification with the following restrictions:

The heads shall be austenitized, quenched, and tempered. The tempering temperature shall be not less than the temperature specified in [Table I-1](#).

- a. The Contractor shall maintain a complete record of the heat treatment given each head. The heat treatment record shall include the time and temperature for the tempering cycle and resizing treatment, and the cooling method used.
- b. After tempering or resizing treatments, the heads shall be cooled quickly (furnace cooling is not permitted) through the temperature range of 1050 to 500 °F (565 to 260 °C) and shall not be held for long periods in this temperature range to preclude temper embrittlement.
- c. All heads that constitute the tempering or stress relief furnace load shall be removed from the furnace and quickly cooled at the same time (i.e., the same quench load). The use of more than one quench load for tempering or stress relief heat treatment of a single furnace load of heads is prohibited.
- d. The heads may be water quenched after tempering at the option of the Contractor.

T9074-BD-GIB-010/0300 Rev 2

- e. Heat treatment procedures and documentation shall be in accordance with Chapters 1 through 6 and Appendix B.

Table I-1. Minimum Tempering Temperature.

Head Thickness, Inches (mm), nominal	Minimum Tempering Temperature, °F (°C)
HY-80 2½ and less (64 mm)	1200 (649)
HY-80 greater than 2½ to 8 (64 to 203 mm)	1175 (635)
HY-100 2½ and less (64 mm)	1150 (621)
HY-100 greater than 2½ to 3 (64 to 76 mm)	1100 (593)

1.3.6 Surface Quality. The depth of rolled-in scale, pit clusters, windrowed condition, or other defects shall not exceed 0.015 inch (0.38 mm) and shall not result in an under gauge (less than minimum thickness) condition. Isolated, individual pits not over 0.030 inch (0.76 mm) deep are acceptable, provided head thickness is not reduced to an under gauge condition. Surface imperfections may be removed by grinding, provided the thickness is not reduced to an under gauge condition and the ground area is well faired into surrounding metal.

1.3.6.1 Weld Repair of Mill Defects After Heat Treatment. When prohibited (see I.6.2), weld repair after final heat treatment shall not be performed. If not prohibited, mill imperfections may be repair welded by the Contractor or referred to the contracting activity for acceptance and so noted on the inspection reports with subsequent repair welding to be performed by the contracting activity. Areas of the head found to have less than the minimum specified thickness may have the thickness restored by welding the depressed area. When weld repairs after final treatment are permitted, the following limitations shall apply:

- a. The total area to be repaired shall not exceed 1 percent of the surface of one side of the head.
- b. The depth of any area to be repaired shall not exceed one-half the minimum head thickness specified or ½ inch (13 mm), whichever is less. The depth of the area to be repaired shall be a minimum of ¼ inch (2 mm).
- c. Areas within 2 inches (51 mm) of each other which require weld repair shall be combined to form a single repair.
- d. Areas to be welded shall be ground to assure that the welds are made on clean, sound metal.
- e. After preparation for repair and prior to welding, all of the depressed areas shall be magnetic particle inspected in accordance with T9074-AS-GIB-010/271, and shown to be free of relevant linear discontinuities.
- f. Weld repairs shall be made in accordance with T9074-AD-GIB-010/1688 or, when specified, the applicable fabrication document (see I.6.2). Procedures and personnel shall be qualified in accordance with S9074-AQ-GIB-010/248.
- g. The final repaired surface shall be ground smooth and shall be essentially flush with the adjacent surface and free of undercut in excess of 0.020 inch (0.5 mm). No point of the finished weld surface shall be below the adjacent plate surface.
- h. Surface weld repairs shall be magnetic particle inspected after final grinding (or subsequent heat treatment, if applicable) in accordance with T9074-AS-GIB-010/271. Welds and ½ inch (13 mm) of adjacent base material shall be free of relevant linear indications greater than ¼ inch (3 mm) in length.
- i. Repaired areas shall be marked. The markings shall remain legible and shall not be removed prior to performing all inspections as specified herein.
- j. Notations of such repaired areas shall be made on the head inspection form as part of the records.
- k. If a non-heat treatable electrode is used, reheat treatment of the head is prohibited. Warm resizing of heads which have been weld repaired with a non-heat treatable electrode is permitted provided the weld repair procedure is qualified in accordance with S9074-AQ-GIB-010/248 following a simulated warm resizing heat treatment.

1.3.6.2 Weld Repair of Mill Defects Prior to Heat Treatment. Weld repairs of mill imperfections may be accomplished prior to heat treatment within the limitations of I.3.6.1 using an acceptable heat treatable electrode.

1.3.7 Form and Dimensions. Heads shall be made to form and dimension as specified (see I.6.2).

I.3.8 Tolerances. The minimum thickness, maximum thickness, contour, and ovality of the head shall be as specified (see I.6.2). Ultrasonic gauging shall be performed in accordance with Appendix B and shall meet the thickness tolerances stated therein.

I.3.9 Ultrasonic Inspection (Base Material for Soundness). Ultrasonic inspection for soundness shall be performed on the base metal of all heads over ½ inch (13 mm) thick in accordance with the requirements of Appendix B and shall meet the acceptance criteria therein. In accordance with Appendix B, plates (i.e., heads) less than ½ inch (13 mm) thick are not required to be ultrasonically inspected.

I.3.10 Cleaning and Preservation. Unless otherwise specified (see I.6.2), the surfaces of the heads shall be descaled and coated as specified in Appendix B.

I.3.11 Explosion Test. The explosion test is required of the weld used to join two-piece heads (see I.4.3.3). Two explosion crack starter specimens of the appropriate two-piece head base material (HY-80 or HY-100) are required for first article testing. Specimens shall conform to the requirements on [Figure L-9](#) and both shall meet the explosion crack starter requirements of Appendix L. When explosion bulge type testing is specified (see I.6.2) testing shall be in accordance with Appendix L and shall meet the requirements of Appendix B.

I.4 VERIFICATION.

I.4.1 Responsibility for Inspection. See 4.1.

I.4.2 Classification of Inspections. The inspection requirements specified herein are classified as follows:

- a. First article inspection (see I.4.3).
- b. Conformance inspection (see I.4.4).

I.4.3 First Article Inspection. First article inspection shall consist of the tests and examinations specified in I.4.3.1 through I.4.3.3 and I.4.5 (see 4.3, 6.3, and Appendix L). A first article inspection report shall be prepared as specified in 3.1.

I.4.3.1 First Article Sample. Prior to delivering steel heads to this specification, the Contractor shall demonstrate that his facility produces acceptable heads. The first article sample shall consist of a steel head representative of normal production (including resizing). Acceptability as a source for Naval acquisitions of heads will be limited to the grade of material, thickness, two-piece or one-piece, subjected to first article testing, unless otherwise approved by NAVSEA.

I.4.3.2 Heads, Base Metal Tests. The following tests shall be performed:

- a. Chemical composition. A ladle analysis and check analysis shall be made of the heat or melt of steel and the rolled mill product involved, respectively, in the first article test and shall conform to Appendix B.
- b. Tensile tests. Test acceptance standards and procedures shall be as specified in I.4.4 and I.4.6.
- c. Impact test. Test acceptance standards and procedures shall be as specified in I.4.4 and I.4.6.

I.4.3.3 Weld Metal Tests. For first article tests of two piece welded heads, the weld procedure must be approved by NAVSEA. In addition to the data required in S9074-AQ-GIB-010/248, all weld metal tensile data and a dynamic tear test transition curve shall be required from the mid-thickness of the weld metal after final heat treatment and resizing. Two dynamic tear tests at each of the following temperatures are required: -60 °F (-51 °C), -40 °F (-40 °C), -20 °F (-29 °C), 0 °F (-18 °C), and +30 °F (-1 °C). The dynamic tear tests shall show that the material has attained the upper shelf of the transition curve by 0 °F. The yield strength of the weld metal tensile specimens shall exceed the minimum required base metal yield strength. Explosion testing in accordance with I.3.11 shall be required of welded test plates.

I.4.4 Conformance Inspection. (i.e., inspections of production lots)

I.4.4.1 Sampling for Conformance Inspection.

I.4.4.1.1 Lot. A lot shall consist of all heads made from the same heat, of the same thickness, and heat treated in the same furnace at the same time.

I.4.4.1.2 Sampling for Chemical or Spectrographic Analysis. Drillings for chemical analysis shall be taken from tensile test specimens from each of two heads from each lot. When only one head is produced from a lot, only one test is required. Solid samples may be taken from tensile coupons for spectrographic analysis.

I.4.4.1.3 Sampling for Tension and Hardness Tests.

I.4.4.1.3.1 One-Piece Heads Up to 48 Inches (1219 mm), Inclusive Outside Diameter (od). After final heat treatment and resizing of the heads, one tension test specimen shall be taken from each of two heads from the same lot. The test specimen shall be taken parallel to the open end of the head and oriented transverse to the final plate rolling direction.

T9074-BD-GIB-010/0300 Rev 2

When only one head is produced from a lot, only one tension test specimen shall be required. Heads not tension tested shall be Brinell hardness tested on the interior and exterior of the head, 180 degrees apart from one another, and shall meet the range of 207 to 255 HB for HY-80 and 241 to 277 HB for HY-100. Those heads not meeting this range shall be rejected or shall be tension tested, in which case the results of the tension tests shall rule (see [Figure I-1](#)).

I.4.4.1.3.2 One-Piece Heads Over 48 Inches (1219 mm) od. After final heat treatment and resizing of the head, two tension test specimens shall be taken from each head, parallel to the open end, and oriented transverse to the final plate rolling direction, 180 degrees apart from one another (see [Figure I-2](#)).

I.4.4.1.3.3 Two-Piece Heads. After final heat treatment and resizing of the head, two tension test specimens shall be taken, 180 degrees apart, from each half of the head adjacent to the weld seam. The specimens shall be taken parallel to the open end of the head and oriented transverse to the final plate rolling direction. Additionally, one tension test specimen shall be taken across the weld to represent the heat treated weld metal (see [Figure I-3](#)).

I.4.4.1.4 Sampling for Impact Tests. A set of impact specimens shall consist of three Charpy V-notch specimens taken with their longitudinal dimensions parallel to the open end of the head and oriented transverse to the final plate rolling direction. The axis of the notch shall be perpendicular to the spherical surfaces of the head. Test specimens shall be obtained from locations shown on [Figure I-1](#), [Figure I-2](#), [Figure I-3](#), and [Figure I-4](#). For base metal in one- and two-piece heads, impact sets shall be tested at -120 °F (-84 °C) and 0 °F (-18 °C). For weld metal in two-piece heads, impact sets shall be tested at -60 °F (-51 °C) and 0 °F (-18 °C). In heads for which plate thicknesses and head curvature permit the removal of dynamic tear test specimens, dynamic tear testing shall be performed in lieu of the Charpy V-notch test. In such cases, a dynamic tear test set shall consist of two specimens and the number, location, and orientation of specimen sets shall be identical to those of Charpy V-notch specimens. For base metal, one dynamic tear test set shall be tested at -40 °F (-40 °C). For weld metal, two dynamic tear test sets shall be tested; one set at +30 °F (-1 °C) and one set at -20 °F (-29 °C). Additionally, a base metal dynamic tear test set shall be tested at 0 °F (-18 °C) for information only.

I.4.4.1.4.1 One-Piece Heads Up to 48 Inches (1219 mm) od, Inclusive. After final heat treatment and resizing, two sets of impact specimens shall be taken 180 degrees apart from each of two heads from the same lot (see [Figure I-1](#)). When only one head is produced from a lot, two sets of impact specimens shall be taken from that head.

I.4.4.1.4.2 One-Piece Heads Over 48 Inches (1219 mm) od. After final heat treatment and resizing of the head, two sets of impact specimens shall be taken from one side of the head and two sets from the opposite side of the head, 180 degrees apart (see [Figure I-2](#)).

I.4.4.1.4.3 Two-Piece Heads. After final heat treatment and resizing, four sets of impact specimens shall be taken from each half of each head adjacent to the weld seam. Additionally, two sets of impact specimens shall be taken from the weld metal seam (see [Figure I-3](#) and [Figure I-4](#)).

I.4.4.2 Mechanical Property Test Locations.

I.4.4.2.1 Heads Up to 6 Inches (152 mm) Thick, Inclusive. Base metal impact and tensile tests shall be taken a minimum distance of one T from the heat treated edge of the head, where T is defined as the gauge of the plate used to make the head. Specimens shall include the material's thickness centerline. For thicknesses less than $\frac{5}{8}$ inch (16 mm), rectangular tensile specimens shall be used. For thicknesses $\frac{5}{8}$ inch (16 mm) and greater, the standard $\frac{1}{2}$ inch (13 mm) round tensile specimens shall be used.

I.4.4.2.2 Heads Over 6 Inches (152 mm) Thick. Base metal impact and tensile tests shall be taken a minimum distance of 1T from the heat treated edge of the head. Base metal tensile tests shall be located at T/2 where T is defined as the gauge of the plate used to make the head. Base metal impact tests shall contain the material's thickness centerline. Tensile tests shall use the standard $\frac{1}{2}$ inch (13 mm) round specimen.

I.4.4.2.3 Weldment Test Specimens. Transverse weldment tensile and impact test specimens shall contain the head's thickness centerline and be taken a minimum distance of one T from the heat treated edge for heads up to 2 inches (51 mm) thick or 1T from the heat treated edge for heads over 2 inches (51 mm) thick.

I.4.4.2.4 Buffer Plate Requirements. In the cases where it is impossible to obtain the test specimens the proper distance from the heat treated edge of the head, buffer plates shall be seal-welded to the edge of the head prior to heat treatment, to maintain the proper distances from the heat treated edges. The buffer plate shall be a minimum of 6T by 1T for heads up to 2 inches (51 mm) thick and 6T by 2T for heads over 2 inches (51 mm) thick. The test specimens shall be centered under the buffer plate to the maximum extent possible.

I.4.4.2.5 Location of Test Specimens in the Head. The specimens shall be located and oriented as shown on [Figure I-1](#), [Figure I-2](#), [Figure I-3](#), and [Figure I-4](#). [Figure I-1](#) and [Figure I-2](#) are for one-piece heads and [Figure I-3](#) and [Figure I-4](#) are for two-piece heads.

I.4.4.2.6 Marking of Test Specimens. The test specimens shall be marked in a way that will ensure positive identification.

I.4.5 Examination.

I.4.5.1 Visual and Dimensional Examination. Each head shall be examined after final heat treatment and resizing for conformance to the requirements of this specification and contract drawings.

I.4.5.2 Radiography and Magnetic Particle Inspection of Two-Piece Head Weldments. Unless otherwise specified (see I.6.2), after all heat treatment and forming operations including resizing, all full penetration welds shall be subjected to magnetic particle and radiographic inspection in accordance with T9074-AS-GIB-010/271. The radiographic inspection results shall meet the Class 2 requirements of MIL-STD-2035. Magnetic particle inspection results for undercut shall meet the Class 2 requirements of MIL-STD-2035.

I.4.6 Methods of Inspection.

I.4.6.1 Chemical Analysis. If the samples selected for analysis fail to meet the requirements of I.3.1, the heads in question shall be subject to rejection. Samples may be taken from each head; those heads meeting the requirements of I.3.1 will be accepted and those failing to meet the requirements shall be rejected.

I.4.6.2 Tensile Test. Unless otherwise specified (see I.6.2), the ultimate tensile strength shall be recorded for information only.

I.4.6.2.1 Tensile Tests, Two-Piece Head. The base metal tensile test shall be conducted in accordance with ASTM A370. The transverse weldment tensile test shall be conducted in accordance with ANSI/AWS B4.0.

I.4.6.3 Impact Tests. Impact tests shall be either Charpy V-notch or dynamic tear to determine whether the material meets the requirement of I.3.3.

I.4.6.4 Nondestructive Inspections. Nondestructive inspection procedures shall be qualified in accordance with T9074-AS-GIB-010/271. Butt welds shall be radiographed for 100 percent of their length.

I.4.6.5 Explosion Tests of Two-Piece Head Weldments. The two-piece head weld shall be used as the weld in the joint evaluated (see I.3.11 and I.4.3.3).

I.4.7 Retests.

I.4.7.1 Impact Retest. If one or more retest specimens falls below the specified minimum for a single impact test value, the head shall be subject to rejection and each individual head of the lot (see I.4.4.1.1) shall be impact tested in accordance with I.4.4.1.4 and I.4.6.3 to determine whether it meets the impact requirements. If an impact test from a head from the same lot as the original impact failure fails to meet the impact requirements, the entire lot shall be subject to rejection.

I.5 PACKAGING.

See Chapter 5.

I.6 NOTES.

I.6.1 Intended Use. HY-80 and HY-100 heat treated heads are intended primarily for use in critical structural applications where a notch-tough, high-strength material is required.

I.6.2 Acquisition Requirements. Acquisition documents must specify the following:

- a. Title, number, and date of this specification.
- b. Steel grade required (HY-80 or HY-100) (see I.3.1).
- c. When weld procedures other than those in accordance with S9074-AQ-GIB-010/248 are required (see I.3.2).
- d. Applicable fabrication document, if other than T9074-AD-GIB-010/1688 (see I.3.2, I.3.4, and I.3.6.1.f).
- e. When weld repair after heat treatment is prohibited (see I.3.6.1).
- f. Form and dimensions of heads required (see I.3.7).
- g. Tolerances required (see I.3.8).
- h. Type of coating required if other than Appendix K (see I.3.10).
- i. When explosion bulge testing is required (see I.3.11).

T9074-BD-GIB-010/0300 Rev 2

- j. When magnetic particle and radiographic inspection is not required (see I.4.5.2).
- k. When ultimate tensile strength is not recorded for information only (see I.4.6.2).

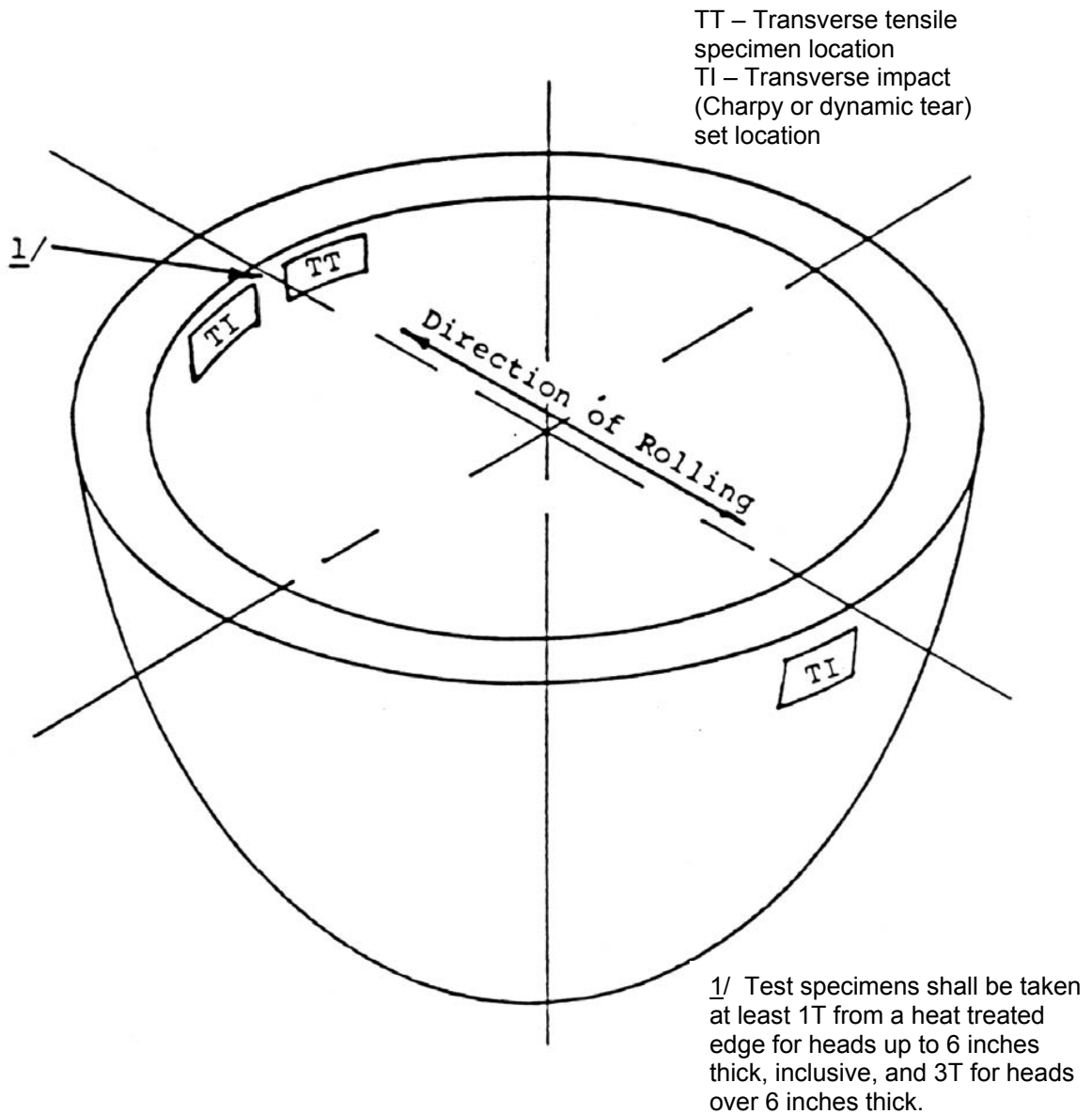
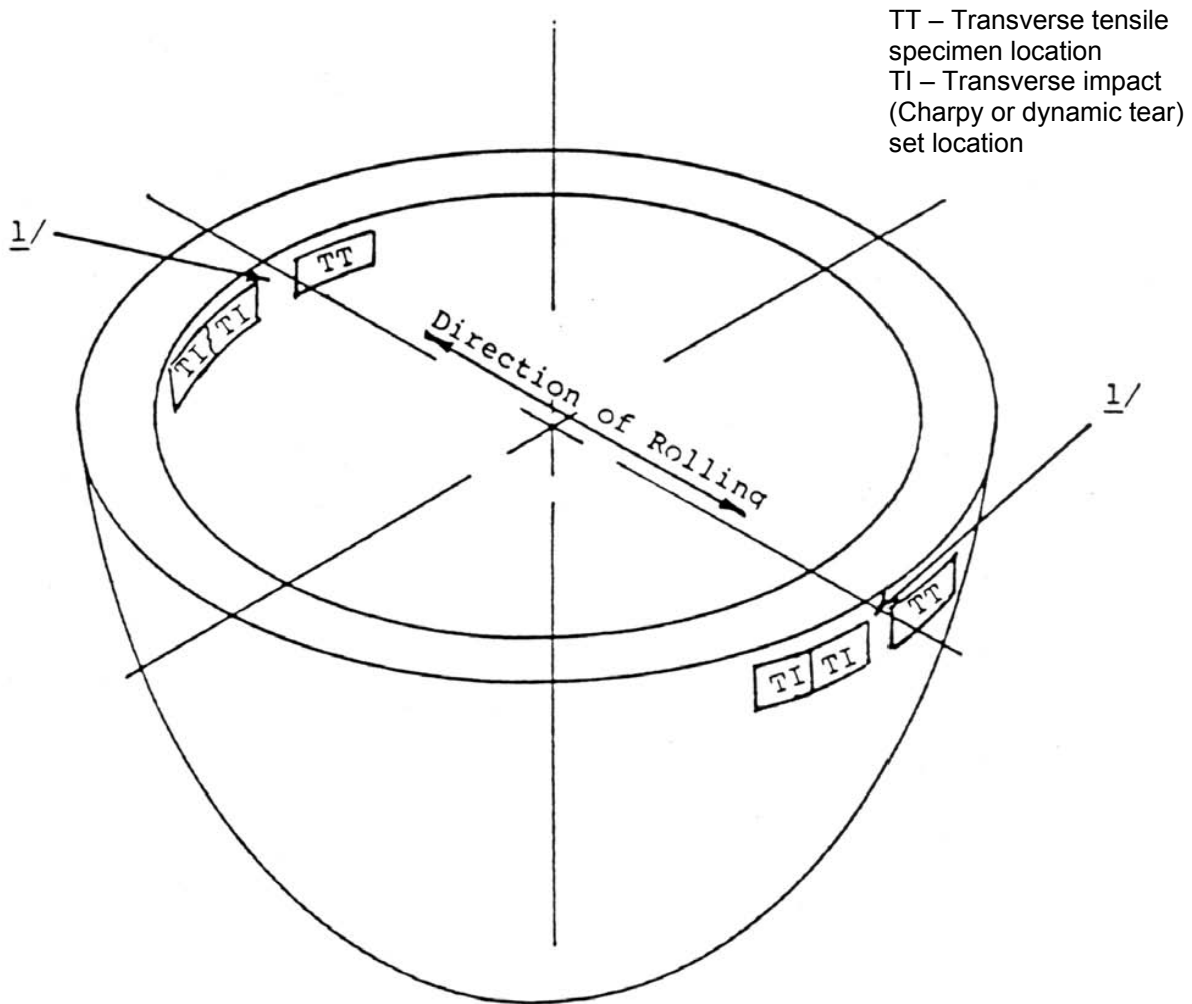

Figure I-1. One-Piece Head Up to 48 Inches (1219 mm) od, Inclusive – Test Layout.
 (See I.4.4.2 for details on test specimen location.)

T9074-BD-GIB-010/0300 Rev 2



1/ Test specimens shall be taken at least 1T from a heat treated edge for heads up to 6 inches thick, inclusive, and 3T for heads over 6 inches thick.

Figure I-2. One-Piece Head Over 48 Inches (1219 mm) od – Test Layout.
 (See I.4.4.2 for details on test specimen location.)

TT – Transverse tensile specimen location – base metal
 TI – Transverse impact (Charpy or dynamic tear) set location – base metal
 TTW – Transverse tensile specimen location – Weld metal
 TIW – Transverse impact (Charpy or dynamic tear) set location – Weld metal

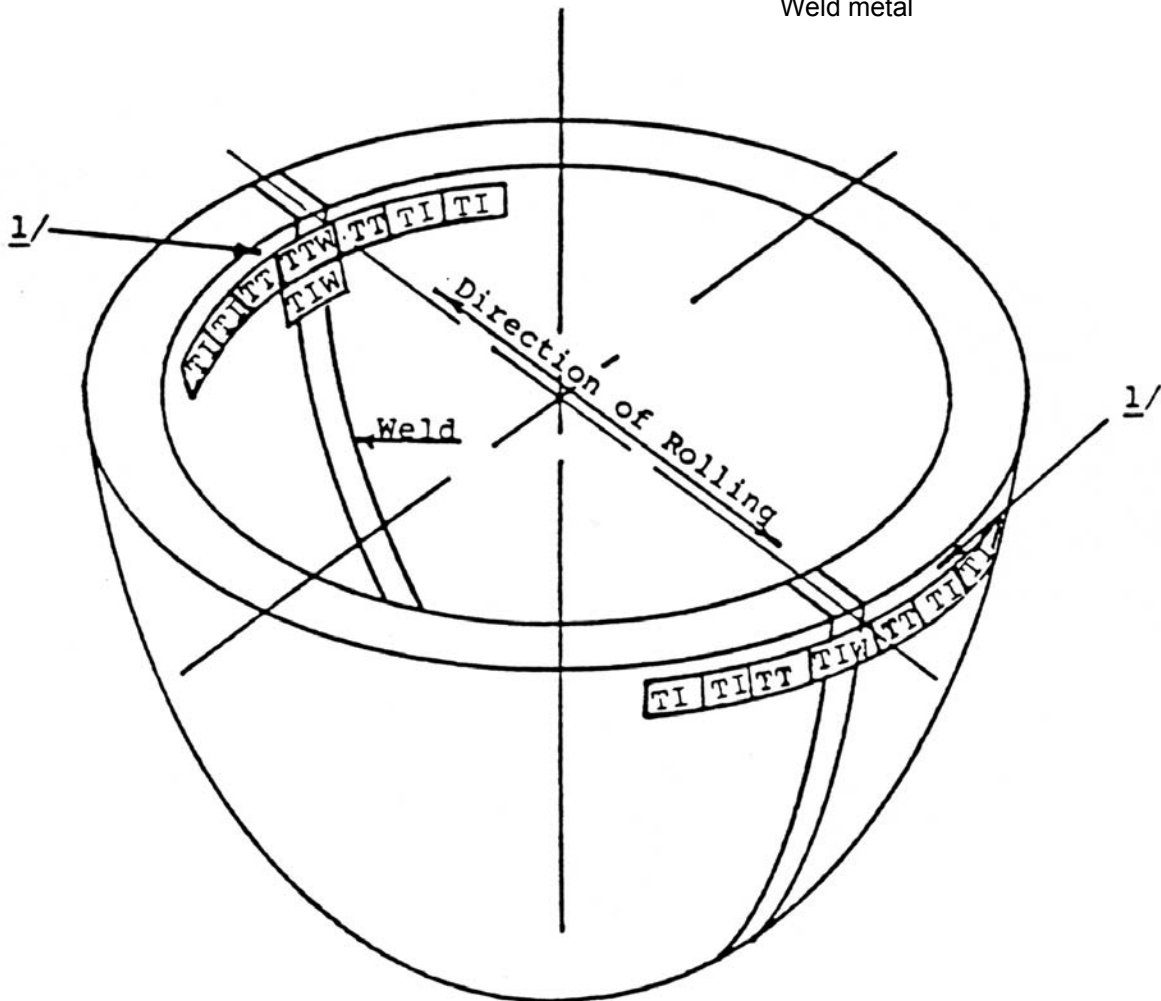

1/ Test specimens shall be taken at least 1T from a heat treated edge for heads up to 6 inches thick, inclusive, and 3T for heads over 6 inches thick.

Figure I-3. Two-Piece Head – Test Layout.
 (See I.4.4.2 for details on test specimen location.)

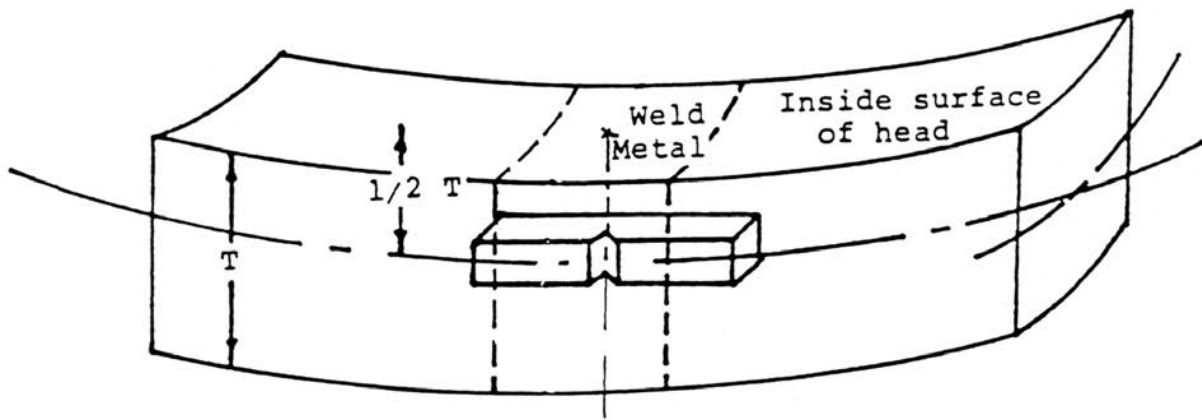

Figure I-4. Location and Orientation of Weld Metal Charpy and Dynamic Tear Impact Specimens on Two-Piece Heads.
(See I.4.4.2 for details on test specimen location.)

APPENDIX J

ULTRASONIC THICKNESS TESTING REQUIREMENTS AND EVALUATION

J.1 SCOPE.

J.1.1 Scope. This appendix describes basic methods of ultrasonic testing the thickness of plate for service acceptability. It describes the basic methods of ultrasonic thickness testing of plates and contains the minimum requirements for equipment, personnel, and extent of evaluation in the inspections for acceptance or rejection. This appendix is a mandatory part of the specification when it is cited. The information contained herein is intended for compliance.

J.2 APPLICABLE DOCUMENTS.

See Chapter 2.

J.3 REQUIREMENTS

J.3.1 General. All personnel, equipment, and procedures used for ultrasonic thickness testing shall be qualified in accordance with T9074-AS-GIB-010/271.

J.3.2 Surface Preparation. The scanning surface of each plate shall be grit-blasted or sandblasted. Additional surface preparation shall be in accordance with T9074-AS-GIB-010/271. Alternatively, the surface preparation requirements of ASTM A435 may be used provided the minimum back surface reflection required by ASTM A435 is maintained during the test.

J.3.3 Extent of Test.

J.3.3.1 Ultrasonic Thickness Measurements. Type II plates, and, when specified, Type I plates, require mechanical and ultrasonic thickness testing. Testing results shall be in accordance with the tolerance acceptance standards specified in the applicable appendix.

J.3.4 Couplant. The couplant chosen should give satisfactory results for the equipment in use and the surface conditions prevailing. In addition, the couplant material should be readily removable from the surface when the test is completed. A water-detergent solution or glycerin provides good test results and is easily removed.

J.3.5 Reference Base Designation. The upper left corner of the plate scan surface shall be indicated to designate this as a common reference base location for layout and recording purposes.

J.4 TECHNIQUES.

J.4.1 Plate Ultrasonic Thickness Testing.

J.4.1.1 Calibration. Ultrasonic plate gauging calibration shall be in accordance with T9074-AS-GIB-010/271.

J.4.1.2 Testing Pattern. Using ultrasonic gauging equipment, the plate thickness shall be measured at each intersection of a grid pattern layout on one major surface of the plate. The layout shall consist of a 6-inch margin inward from each edge of the plate, enclosing a grid pattern of lines at 24-inch intervals. Grid spacing dimensions shall be referenced from the upper left corner of the margin. If mechanized scanning is employed, the average of the readings obtained on each 24-inch scan length may be used as plate gauge. All points on the scan lines shall meet the requirements of the applicable appendix.

J.4.1.2.1 Expanded Search. Ultrasonic thickness testing readouts that vary from the specified allowable tolerances shall be submitted to an expanded search to determine the extent of plate area not within tolerance limits.

J.4.1.3 Reporting. The mechanical and ultrasonic thickness testing readings shall be recorded on a form that approximates the shape of the plate. A suggested form layout is depicted on [Figure J-1](#).

J.4.2 Acceptance Criteria.

J.4.2.1 Thickness Testing. All areas of the material that have thickness measurements outside the allowable thickness tolerances specified in the applicable appendix (above or below) shall be reported. A suggested form layout is depicted on [Figure J-1](#).

J.4.3 Reporting. When specified, the mechanical and ultrasonic thickness testing report and the soundness inspection report shall be made available to NAVSEA.

T9074-BD-GIB-010/0300 Rev 2

J.5 PACKAGING.

This section is not applicable to this appendix.

J.6 NOTES.

This section is not applicable to this appendix.

TOP	6"	18"	30"	42"	54"	66"	78"	90"	102"	114"	126"		
Micrometer	← Micrometer												JOB
6"													MILL MARK NO.
18"													HEAT/MELT NO.
30"													SLAB/PLATE NO.
42"													
54"													
66"													
78"													
90"													
102"													
114"													
126"													
138"													
150"													
162"													
174"													
186"													
198"													
210"													
222"													
234"													
246"													
258"													
270"													
282"													
294"													
306"													
318"													
330"													
342"													
354"													
366"													
378"													
390"													
402"													
414"													
426"													
438"													
450"													
462"													
Micrometer	← Micrometer												

MATERIAL				LENGTH	WIDTH	GAUGE
				"	"	"
THICKNESS		MINIMUM		MAXIMUM		
ALLOWABLE		"		"		"
MEASURED		"		"		"
DEVIATION		"		"		"
SPECIFICATION/PROCEDURE NO.						
INSTRUMENT			MODEL NO.			
TRANSDUCER SIZE				FREQ.		
				MHz		
AUXILIARY EQUIPMENT						
INSPECTOR/CERT. LEVEL DATE						
REVIEWED BY: DATE						

Figure J-1. Sample Plate Gauging Report (Micrometer and Ultrasonic).

T9074-BD-GIB-010/0300 Rev 2

THIS PAGE INTENTIONALLY LEFT BLANK

APPENDIX K COATINGS

K.1 SCOPE.

K.1.1 Scope. This appendix outlines the cleaning and preserving procedures and requirements for ships' plates intended for Naval service. When called for, this appendix forms a mandatory part of this specification.

K.1.2 Storage. This appendix allows the maximum latitude in cleaning and preserving methods and materials for the intended plate storage time and conditions.

K.2 APPLICABLE DOCUMENTS.

See Chapter 2.

K.3 REQUIREMENTS.

K.3.1 Coating. The plates, as prepared for coating, shall be in the descaled condition and free from visible rust. The paint film shall cover surface roughness peaks. Two random dry film thickness measurements per 100 square feet of painted surface, made with a calibrated suitable thickness gauge, shall be sufficient for determining conformity of any one plate to the specified coating thicknesses. Other methods of measurement may be used for paint film thickness, subject to the approval of the Command or Agency concerned. Organic coatings containing lead, chromium, asbestos, arsenic, or mercury shall not be used. Coatings shall be as specified in K.3.1.1 through K.3.1.5.

K.3.1.1 HSLA-80. Plates, sheets, or coils shall be cleaned by either abrasive blast cleaning or acid pickling. One coat of primer in accordance with FED-STD-595 (color number 37778 - white) shall be applied to a dry film thickness of approximately 1 mil. The drying time of the coating at 73 °F (23 °C) shall be a maximum of 6 hours. The thickness of the dry film shall be not less than 0.7 mil at any point. The Contractor shall choose a coating compatible with the intended application and duration of protection as specified (see K.6.2).

K.3.1.2 HSLA-100. Plates, sheets, or coils shall be cleaned by either abrasive blast cleaning or acid pickling. One coat of primer in accordance with FED-STD-595 (color number 31668 - pink) shall be applied to a dry film thickness of approximately 1 mil. The drying time of the coating at 73 °F (23 °C) shall be a maximum of 6 hours. The thickness of the dry film shall be not less than 0.7 mil at any point. The Contractor shall choose a coating compatible with the intended application and duration of protection as specified (see K.6.2).

K.3.1.3 HY-80. Plates shall be cleaned by either abrasive blast cleaning or acid pickling. One coat of primer conforming to formula 84 (brown) of TT-P-645 approximating color number 30117 of FED-STD-595 shall be applied to an average dry film thickness of approximately 1 mil. The drying time of the coating at 73 °F (23 °C) shall be a maximum of 6 hours. When modified to meet the color requirements, primers conforming to either TT-P-1757 or TT-P-664 are acceptable. These primers have a maximum drying time of 30 minutes, and therefore allow the effective use of automated cleaning and painting.

K.3.1.4 HY-100. Plates shall be cleaned by either abrasive blast cleaning or acid pickling. One coat of alkyd primer conforming to TT-P-645 modified to a dull orange approximating color number 22190 of FED-STD-595 shall be applied to an average dry film thickness of approximately 1 mil. The drying time of the coating at 73 °F (23 °C) shall be a maximum of 6 hours. When modified to meet the color requirements, primers conforming to either TT-P-1757 or TT-P-664 are acceptable. These primers have a maximum drying time of 30 minutes, and therefore allow the effective use of automated cleaning and painting.

K.3.1.5 HY-130. Plates shall be descaled and cleaned by abrasive blast cleaning. Chemical pickling is prohibited. The plates shall be coated with one coat of pretreatment in accordance with DOD-P-15328 (formula number 117), to a dry film thickness of 0.3 to 0.5 mil, followed by one coat of alkyd primer (blue) in accordance with MIL-P-24351 (formula number 6N35-2) to an approximate dry film thickness of 1 mil. Thickness of the dry film shall be not less than 0.7 mil at any point. The drying time of the pretreatment shall be 15 to 30 minutes, and the drying time of the 6N35-2 shall be 6 hours maximum.

K.3.1.5.1 Color Cards. Color cards for formula number 6N35-2 may be obtained from Specification Sales (Code 3FRSBS), Building 197, Washington Navy Yard, General Services Administration, Washington, DC 20407. The purpose for which the color cards are desired shall be specified.

T9074-BD-GIB-010/0300 Rev 2

K.4 PROCEDURES.

K.4.1 Descaling and Cleaning.

K.4.1.1 Abrasive Blast Cleaning. Abrasive blast cleaning shall result in a clean metal surface for painting, with mill scale, rust, and other surface contaminants completely removed.

K.4.1.2 Acid Pickling. The acid pickling process shall be as follows:

- a. Plates, sheets, or coils shall be handled on edge throughout the various steps of the procedures. They shall not be laid flat in the solutions.
- b. Rust preventatives, oils, greases, oil paints, and other foreign matter shall be removed from the plates prior to immersion in the acid pickling bath. Where alkaline solutions are used for this purpose, the plates shall be thoroughly rinsed with water prior to pickling.
- c. The pickling bath shall consist of a sulphuric acid solution to which has been added pickling inhibitor and 1½ percent of sodium chloride. In making the solution initially, 5 gallons of concentrated sulphuric acid are used for each 100 gallons of solution. The acid concentration shall not be allowed to drop below 3.5 percent by volume. The inhibitor shall be used at the concentration recommended by the manufacturer. The bath temperature shall be maintained at 160 to 180 °F. When the concentration of iron in the solution reaches 5 percent by weight, the entire bath shall be discarded.
- d. The water rinse shall consist of fresh circulating water maintained at a temperature of 120 to 180 °F. The flow of fresh water shall be maintained so that a complete change of water occurs every 24 hours. The combined concentrations of sulphuric acid and iron sulfates in the bath, calculated from the acid concentration and the ferrous iron concentration, shall not exceed 2 grams per gallon. This determination shall be made at least once each week.

K.5 PACKAGING.

This section is not applicable to this appendix.

K.6 NOTES.

K.6.1 Intended Use. These coatings are designed to provide protection for coils, sheets, and plates intended for Naval service.

K.6.2 Acquisition Requirements. Acquisition documents must specify the following:

- a. Title, number, and date of this specification.
- b. Intended application and duration of protection required (see K.3.1.1 and K.3.1.2).

APPENDIX L (2149)

STANDARD PROCEDURES FOR EXPLOSION TESTING FERROUS AND NON-FERROUS METALLIC MATERIALS AND WELDMENTS

L.1 SCOPE.

L.1.1 Scope. This standard covers explosion testing used to evaluate ferrous and non-ferrous base materials, welding filler materials, and welding procedures when required by applicable specifications, contracts, acquisitioning documents, and other authorities.

L.1.2 Test Methods. Three test methods are described herein.

- a. Explosion crack starter testing - filler metals and base plate.
- b. Explosion bulge testing - filler metals and base plate.
- c. Explosion tear testing - primarily titanium.

L.1.3 Approval Authority. Any requirements contained in this standard specifically requiring Naval Sea Systems Command (NAVSEA) approval shall be forwarded to the Naval Sea Systems Command, Assistant Director, Materials Engineering, 1333 Isaac Hull Ave. SE, Washington Navy Yard, DC 20376-5130.

L.2 APPLICABLE DOCUMENTS.

See Chapter 2.

L.3 DEFINITIONS.

L.3.1 General. Except as noted herein, welding nomenclature and definitions shall be in accordance with ANSI/AWS A3.0.

L.3.1.1 All-Weld-Metal Test Specimen. An all-weld-metal test specimen is a test specimen wherein the portion being tested is composed totally of deposited weld metal.

L.3.1.2 Bulge Area. Bulge area is an unrestrained area of weldment test specimen subjected to explosive loading.

L.3.1.3 Compression Side. The compression side is that surface of the test specimen facing the explosive.

L.3.1.4 Crack Starter Bead. A crack starter bead is the brittle weld metal deposited on the weldment to present a sharp crack front to the weld or Heat Affected Zone (HAZ) or base metal for the purpose of assessing the resistance to cracking of the material being tested.

L.3.1.5 Explosion Test. An explosion test is a general term applicable to the explosion crack starter, explosion bulge, and explosion tear tests as covered herein.

L.3.1.6 Explosion Bulge Test. An explosion bulge test is an explosion test principally used to qualify prospective Contractors' products wherein a flat test plate specimen or weldment is explosively loaded into a circular test die.

L.3.1.7 Explosion Crack Starter Test. An explosion crack starter test is an explosion bulge test plate with a deposited and notched crack starter bead.

L.3.1.8 Explosion Tear Test (ETT). An explosion tear test is a slotted explosion test used where preferential transverse loading of the test specimen is specified.

L.3.1.9 Explosive. An explosive is a material that, when detonated, generates, by instantaneous burning, rapidly expanding gases producing sufficient force to plastically deform the metallic materials under test.

L.3.1.10 Explosive Standoff Distance. Explosive stand-off distance is the distance measured from the top face of the explosion test die to the bottom surface of the explosive charge.

L.3.1.11 Finished Weld. A finished weld is a weld which has received final inspection and has been accepted.

L.3.1.12 Heat Soak. Heat soak is any application of heat, during or on completion of welding, to a weld joint to promote hydrogen removal.

L.3.1.13 Hold-Down Area. The hold-down area is that portion of the weldment resting on the die.

T9074-BD-GIB-010/0300 Rev 2

L.3.1.14 Prolongation. Prolongation is an explosion test specimen or weldment extension intended for mechanical testing. Prolongation length will depend on the number of mechanical tests planned.

L.3.1.15 Reduction in Thickness (Percent). Reduction in thickness is the percent plate thickness reduction affected by explosive loadings. It shall be calculated from measurements taken at a standardized location (see L.9.3.5).

L.3.1.16 Tension Side. The tension side is that surface of the weldment located away from the explosive charge.

L.4 GENERAL REQUIREMENTS.

L.4.1 Material Qualification. When explosion testing is required to be conducted by Military specifications for base metal or filler metal, Contractors shall prepare data for the material on which qualification is proposed by the instructions of the applicable material specification. Prior to fabricating the test weldments, all filler metal lots to be used when base metal is being evaluated or all base metal to be used when weld metal is being evaluated shall be receipt inspected in accordance with the applicable specification.

L.5 DETAILED REQUIREMENTS.

L.5.1 Mechanical Test Samples. Mechanical test specimens [prolongations to explosion test specimens (see [Figure L-1](#), [Figure L-2](#), and [Figure L-3](#))] shall be prepared and tested by the authorized Government laboratory performing the explosion testing. Quantities and test specimen details shall be in accordance with L.6 and L.7. Mechanical properties of the base metal or weld metal shall be evaluated in accordance with the applicable specification. The feasibility of a successful explosion test shall be determined by the authorized Government laboratory on the basis of the material's mechanical properties. The mechanical test prolongations shall be prepared integral with the explosion test specimens and shall be severed by flame or saw cutting. Mechanical test specimens shall be machined from the prolongations in accordance with [Figure L-2](#) and [Figure L-3](#).

L.5.2 Explosion Crack Starter Samples. Explosion crack starter specimens shall be prepared by the Government laboratory performing the explosion testing. Quantities and explosion test specimen details shall be in accordance with L.6 and L.7. The explosion crack starter test and the explosion bulge test are used in the evaluation of base metals, weld metals, heat affected zones, weld fusion zones, and welding procedures. Normally, when the explosion crack starter test results are unsatisfactory, the explosion bulge test is not conducted. However, when requested in advance of testing by the prospective Contractor, and agreed to by the Government laboratory conducting the explosion testing, the explosion bulge samples may be tested to support the failure and provide additional information or data on the cause of failure.

L.5.3 Explosion Bulge Specimens. Explosion bulge test specimens shall be prepared by the Government laboratory performing the explosion testing. Explosion test specimens may be prepared by the vendor or fabricating activity when required, if adequate, approved welding procedures are in place. Quantities and test specimen details shall be in accordance with L.6 and L.7 (see [Figure L-1](#) and [Figure L-4](#)).

L.5.4 Explosion Tear Test. Explosion tear test specimens shall be prepared (see L.8) and tested by a Government laboratory to determine the performance of transversely loaded test specimens with respect to high strain rate loading (see [Figure L-5](#)).

L.6 QUALIFICATION CONDITION OF MATERIAL.

L.6.1 Base Metal Product Forms. When seeking approval to produce one of the below listed product forms requiring explosion bulge testing, the Contractor shall furnish material in accordance with L.6.1.1 through L.6.1.4, unless otherwise specified by the authorized Government laboratory.

L.6.1.1 Rolled Plate. Contractor shall provide sufficient rolled plate to produce a minimum of two, 2- by 50- by 30-inch explosion/mechanical prolongation weldments and four, 2- by 30- by 30-inch explosion weldments. The plate surfaces shall be in the as-rolled condition. The material shall be from plate taken from the topmost portion of the ingot or slab, see 4.3.1. [Figure L-1](#) defines the required orientation of the major rolling direction. Crack starter candidates shall be selected from the test specimens by the authorized Government laboratory.

L.6.1.2 Castings. Contractor shall provide sufficient cast plate to produce a minimum of two, 2- by 50- by 30-inch explosion/mechanical prolongation weldments and four 2- by 30- by 30-inch explosion weldments. The cast plate shall be submitted with surfaces (both sides) machined to a 250 micro-inch finish or better to provide a uniform 2-inch thickness. Crack starter candidates shall be selected from the test specimens by the authorized Government laboratory.

L.6.1.3 Forgings and Shapes. Contractor shall provide sufficient forged shaped plate to produce a minimum of two, 2- by 50- by 30-inch explosion/mechanical prolongation weldments and four, 2- by 30- by 30-inch explosion weldments. The forged or shaped plate surfaces (both sides) shall be submitted machined to a 250 micro-inch finish or better to provide a

uniform 2-inch thickness. Crack starter candidates shall be selected from the test specimens by the authorized Government laboratory.

L.6.1.4 Maximum 1-Inch Thickness Material. Where the maximum material thickness to be produced is 1 inch or less and explosion bulge testing is specified, the above applies except plate sizes shall be 20 inches wide by 60 inches long for explosion/mechanical prolongation weldments and 20 by 20 inches for explosion weldments.

L.6.2 Filler Metals. When seeking approval to produce filler metals that require testing, the Contractor, when not specifically directed by the Military specification, shall furnish sufficient filler metal to produce a minimum of two 2- by 50- by 30-inch explosion/mechanical prolongation weldments. If explosion bulge testing is to be performed, additional 2- by 30- by 30-inch explosion weldments may be required as specified by the authorized Government laboratory.

L.6.3 Welding Procedure. When seeking approval for a welding process or procedure, the activity shall furnish sufficient rolled, forged or cast plate to produce two 2- by 50- by 30-inch explosion/mechanical prolongation weldments. If explosion bulge testing is to be performed, additional 2- by 30- by 30-inch explosion weldments may be required as specified by the authorized Government laboratory. The plates and filler metal shall be in accordance with the applicable Military specifications.

L.7 PREPARATION AND WELDING OF EXPLOSION TEST WELDMENTS WITH AND WITHOUT MECHANICAL PROLONGATION.

L.7.1 Preparation of Base Metal for Welding. Rolled plate material may be used in the as-rolled "mill finish" condition. Cast, forged, extruded material forms shall be machined or ground, both sides, to provide a uniform plate thickness. Unless otherwise specified, weld joints and approved double-V bevels shall be prepared in accordance with [Figure L-6](#). Double-V groove bevels shall be applied by machining or oxy-fuel cutting provided the flame cutting operation produces a smooth uniform bevel. Bevel preparation residue (cutting oils or flame cutting scale remnant from the weld bevel preparation operation) shall be removed prior to welding. For wrought materials, the weld bevel shall be oriented parallel to the primary rolling or working direction of the base materials.

L.7.2 Welding of Samples. Welding of samples shall be in accordance with L.7.2.1 and L.7.2.2.

L.7.2.1 Base Metal. For base metal qualification, all samples shall be welded in accordance with an approved welding procedure incorporating the required applicable material or fabrication document requirements or both.

L.7.2.2 Electrodes and Welding Procedures. For testing electrodes and qualifying welding processes and procedures, the welding parameters shall be established by the prospective Contractor or qualifying activity.

L.7.3 Nondestructive Evaluation of Test Weldments. When 48 hours have elapsed after completion of welding, the following nondestructive tests in accordance with L.7.3.1 through L.7.3.3 shall be conducted with the weld reinforcement in place except for the hold-down areas.

L.7.3.1 Visual Inspection. Weldments shall be evaluated in accordance with T9074-AS-GIB-010/271 and meet the criteria of the Class 1 Acceptance Standard of MIL-STD-2035. Additionally, the weldments shall be checked for flatness. Base plate rotation due to weld metal shrinkage shall not exceed 5 degrees. Maximum joint offset due to fit-up shall not exceed $\frac{1}{8}$ inch.

L.7.3.2 Radiographic Inspection (RT). Weldments shall be radiographed in accordance with T9074-AS-GIB-010/271 and meet the criteria of the Class 1 Acceptance Standard of MIL-STD-2035.

L.7.3.3 Magnetic Particle Inspection (MT). Weldments shall be inspected in accordance with T9074-AS-GIB-010/271 and meet the criteria of the Class 1 Acceptance Standard of MIL-STD-2035.

L.8 PREPARATION OF TEST ASSEMBLIES FOR EXPLOSION TESTING.

L.8.1 Crack Starter Specimen Preparation. The explosion crack starter test assembly is modified explosion test specimen on which brittle Murex Hardex N or equivalent crack starter beads have been placed. The deposits may be oriented one of two ways depending on the intent of the test; base metal evaluation (see L.8.1.1); or weld metal or weld procedure evaluation (see L.8.1.2 and [Figure L-7](#), [Figure L-8](#), and [Figure L-9](#)).

L.8.1.1 Base Metal Evaluations. For base metal evaluations incorporating weld joint, the Hardex N or equivalent weld deposits shall be placed directly on the weld joint parallel to the axis of the weld as specified on [Figure L-7](#) (plan view). On 2-inch thick specimens, two beads shall be deposited an equal distance from the weld centerline and $\frac{1}{16}$ to $\frac{3}{32}$ inches from the edge of the weld fusion lines. On 1-inch thick specimens, one bead shall be deposited along the weld centerline. The beads shall be 2 to 3 inches long and shall be placed midway between the extremities of the weld joint. For base metal evaluations without a weld joint, the beads shall be placed transverse to the plate primary working direction (cast plates have no primary

T9074-BD-GIB-010/0300 Rev 2

working direction) at the center of the test specimen as specified on [Figure L-8](#). Where two beads are deposited, the beads shall be spaced $\frac{5}{8}$ inch from each side of the plate centerline.

L.8.1.2 Weld Metal and Weld Procedure Evaluations. For weld metal and weld procedure evaluations, the Hardex N or equivalent weld deposits shall be placed directly on the weld joint transverse to the axis of the weld as specified on [Figure L-9](#) (plan view). On 2-inch thick specimens, two beads shall be deposited $\frac{5}{8}$ inch from each side of the plate centerline. On 1-inch thick specimens, one bead shall be deposited on the plate centerline. The beads shall be 2 to 3 inches long and extend $\frac{1}{4}$ inch beyond both weld fusion lines. Where the weld joint is wider than $2\frac{1}{2}$ inches, allowance shall be made to increase the bead length to achieve the minimum $\frac{1}{4}$ inch extension beyond the weld fusion lines. This may require increasing the distance from the weld centerline to the reduction of thickness point of measurement.

L.8.1.3 Crack Starter Bead Application. The Government laboratory authorized to perform the testing shall be responsible for the crack starter bead application. The required welding parameters are as follows:

- a. Process: Shielded metal arc, direct current, electrode positive (DCEP)
- b. Electrode: $\frac{3}{16}$ -inch diameter
- c. Position: Flat, down hand
- d. Welding current and voltage: 180 – 190 amps: 22 – 23 volts
- e. Travel speed: 4.5 – 5.0 inches per minute

Welding shall be performed using a stringer bead technique. Bead width shall not exceed $\frac{5}{8}$ inch. Welding progression shall be as specified on [Figure L-7](#), [Figure L-8](#), and [Figure L-9](#). Before breaking the arc, back-fill the crater to assure adequate weld metal for grinding of the crack starter notch.

L.8.1.4 Notching the Hardex N or Equivalent Weld Bead. Final preparation of the crack starter specimen shall consist of notching the crack starter beads as specified on [Figure L-7](#), [Figure L-8](#), and [Figure L-9](#). For base metal evaluations, the crack starter beads shall be notched mid-length. For weld metal and weld procedure evaluation, the crack starter beads shall be notched at mid-length and over each fusion line. Notching may be accomplished with a thin 1-inch diameter abrasive disk. Notches shall be cut normal to the specimen and across the full width of the bead to a depth such that 0.070 to 0.100 inch remains between the bottom of the notch and the surface of the underlying weldment or plate to be tested. The notch shall not be cut into either the underlying weld joint or base plate.

L.8.2 Explosion Bulge Preparation. Explosion bulge test assemblies shall be prepared in accordance with [Figure L-4](#) and the fabrication and inspection parameters outlined in L.7.

L.8.3 Explosion Tear Test Specimen. Explosion tear test assemblies shall be prepared in accordance with [Figure L-5](#) employing the fabrication and inspection parameters outlined in L.7. To date, principally 1-inch thick tear test weldments have been tested. For this reason the dimensions for a 1-inch test assembly are illustrated.

L.8.4 Grinding for Die Fit and Drilling Thermocouple Holes. Test assembly types listed above shall be prepared for die fit. Because of weld reinforcement or possible unusual test specimen irregularities, preparation of the test assembly shall consist of grinding the weld reinforcement flush for approximately 6 inches in from the assembly edges (see [Figure L-4](#)). Explosion tear test assemblies shall be ground from the test assembly edges to the slots. Additionally, to facilitate temperature monitoring of the explosion test specimen, both while normalizing in the cooling medium and when setting on the explosion test die, thermocouple holes shall be drilled in the edges of each explosion test specimen. The holes shall be approximately $\frac{1}{8}$ inch in diameter by 1 inch deep located at the specimen edge, that is, thickness centerline, a minimum of 1 inch away from any corner of the plate.

L.9 MECHANICAL AND EXPLOSION TESTING.

L.9.1 Mechanical Test Assembly Requirements. The requirements for obtaining the mechanical specimens, as specified on [Figure L-2](#), from the prolongations to the explosion crack starter weldments shall be in accordance with L.9.1.1 through L.9.1.4. Specimens shall be taken for conformance testing to the requirements of the appendix that initiated the explosion testing.

L.9.1.1 Tensile Test Specimens. Weld metal tensile specimens shall be the 0.505-inch diameter size when permitted by the weld joint configuration and base material thickness; otherwise, they shall be the maximum size possible. Two-inch thick test weldments will have both base material and weld metal thickness to permit the removal of two Type R-1, 0.505-inch diameter tensile specimens. Tensile specimens shall be prepared and tested in accordance with ANSI/AWS B4.0.

L.9.1.2 Charpy V-Notch Specimens. Charpy V-notch (CVN) specimens shall be taken so that the surface of the specimen nearest the surface of the test assembly is $\frac{3}{16}$ to $\frac{5}{16}$ inch from the test assembly surface. The specimens shall be

notched as specified on [Figure L-2](#). For the weld metal specimens, light chemical etching of the specimen is recommended to locate the notch within the weld metal. The CVN specimens shall be machined and tested in accordance with ANSI/AWS B4.0.

L.9.1.3 Dynamic Tear Test Specimens. Standard $\frac{5}{8}$ -inch, dynamic tear (DT) specimens shall be machined and tested in accordance with ASTM E604. Specimens shall be taken so that the surface of the specimen nearest the surface of the test assembly is $\frac{3}{16}$ to $\frac{5}{16}$ inch from the test assembly surface. The DT specimens shall be notched as specified on [Figure L-2](#). For the weld metal specimens, light chemical etching of the specimen is recommended to locate the notch within the weld metal.

L.9.1.4 Bend Specimens. Transverse full section side bends, when required, shall be removed from weldments and shall be prepared and tested in accordance with ANSI/AWS B4.0.

L.9.2 Explosion Test Assembly Requirements. The type of explosion test and number of test specimens shall be as specified in the applicable appendix. The acceptance criteria for the explosion tear test shall be as specified in the applicable appendix. The acceptance criteria for the explosion crack starter and bulge tests shall be as specified in [Table L-1](#) and the applicable appendix.

L.9.2.1 Explosion Crack Starter Testing. The crack starter specimens are tested prior to the explosion bulge specimens. Two explosive loadings (shots) shall be detonated, unless the specimen fails to meet the requirements of [Table L-1](#) on the first shot.

L.9.2.2 Explosion Bulge Testing. The explosion bulge specimens require the application of repeated explosive loadings to assess the critical regions of the weldment under high strain rate loading. The explosion bulge test specimens shall be tested by repeated explosive shots until failure occurs or until the minimum reduction in thickness required by the material specification is met. The reduction in thickness shall be measured at the locations specified on [Figure L-4](#) by the methods shown on [Figure L-10](#).

Table L-1. Explosion Test Acceptance Criteria. [1/](#), [2/](#)

	Crack Starter Test		Bulge Test		
	First Shot	Second Shot	First Shot	Second Shot	Additional Tests
Crack starter bead shall crack	X	3/	N/A	N/A	N/A
No piece shall be thrown out of material being tested	X	X	X	X	X
No through-thickness cracks shall be present	X	N/R	X	X	N/R
No cracks shall extend into the hold-down area	X	X	X	X	X
Percent reduction in thickness	4/	4/	4/	4/	5/
NOTES:					
<p>1/ Conditions required for each shot are marked with an "X". The suffix RC added to the MIL type pertains to restriction of the copper content (see 3.5). All requirements, tests and acceptance criteria remain otherwise unchanged.</p> <p>2/ N/R = not required.</p> <p>3/ In the event the crack starter bead does not crack on the first shot, the first shot shall be repeated.</p> <p>4/ The percent reduction in thickness shall be recorded for information only.</p> <p>5/ The required percent reduction in thickness shall be as specified in the applicable appendix. Shots shall be discontinued when the metal fails to meet the above conditions, or when the reduction in thickness requirements are met.</p>					

L.9.2.2.1 No Tests. When testing plate properties, failures confined to the weld metal shall be considered no test. When testing weld metal properties, failures through the plate shall be considered no test. In both cases retest may be required on additional specimens dependent on the results of engineering analysis of the failure, or failure mode, or both.

L.9.3 Explosion Test Procedure. Explosion test specimens shall be subjected to the following as specified in L.9.3.1 through L.9.3.6.

L.9.3.1 Refrigeration of Test Specimens. The test specimens shall be cooled (refrigerated) to a temperature below the required test temperature so that any heat gain during handling will not cause the test temperature to be exceeded. Any refrigeration equipment attaining and maintaining the test temperature in the samples is acceptable. Experience has shown

T9074-BD-GIB-010/0300 Rev 2

the use of a liquid nitrogen- or dry ice-cooled alcohol medium to be a relatively inexpensive and extremely efficient method of cooling test specimens. An advantage to this type of cooling system is that there is no need for electrical power. Where circulated air cooling medium cold boxes are employed, a mechanical refrigeration cold box with a propeller type air circulator is superior to the dry ice type equipped with a squirrel cage centrifugal type circulator.

L.9.3.1.1 Establishment of Test Assembly Cooling Requirements. When employing refrigeration to cool test specimens, it will normally be necessary to refrigerate to a level below the testing temperature to compensate for heat gain during handling. Rate of heat gain is a function of plate thickness, ambient temperature, and the time lapse between removal from the cooling medium and detonating the explosive. The degree of undercooling employed shall be determined by making use of "control" plates to develop supporting test data that establish the required amount of undercooling. Supporting test data shall include continuous strip chart temperature recordings showing explosion test assembly temperature rise as a function of time from removal from cooling medium through placement on the test die, and reaching final test temperature. Temperature data shall be obtained from at least three thermocouples, one of which is located in mid-thickness at the center of the test assembly.

L.9.3.1.2 Cooling Procedure. Test specimens in the cooling medium shall be allowed to normalize in temperature through thickness. The time required shall be based on specimen thickness. The minimum time shall be 1 hour per inch of thickness. Deviation from this procedure to shorten the test specimen conditioning time shall be supported by data, which shall be approved by NAVSEA. Plate temperature monitoring, while in the cooling medium shall be by thermocouples imbedded in the plate edges. Preliminary testing shall be used to establish the correlation between plate edge temperature and plate center mid-thickness temperature. To further ensure proper thermal control from cooling medium to explosive loading, the test plate shall incorporate thermocouple monitoring.

L.9.3.2 Setting the Explosion Test Specimen and Detonation of Explosive Charge. On completion of thermal conditioning, the specimen shall be placed on the die (see [Figure L-11](#)) with the ground hold down surfaces contacting the die. The explosive charge shall be centered over the specimen with the proper standoff distance (see [Figure L-11](#)). The standoff distances for explosion bulge type tests for all materials, except HY-130, shall be 15 (minus 0, plus 1) inches. The standoff distance for HY-130 shall be 17 ($\pm 1/2$) inches. The blasting cap may be placed on or in the explosive charge using the following method:

Placed no deeper than $3/4$ inch into a predrilled or precast 0.300-inch diameter hole located in the top center of the explosive charge.

L.9.3.3 Explosive Types. Historically, composition C3 and C4 explosive was replaced by 50 and 50 pentolite. Fifty and 50 pentolite explosive is a combination of 50 percent PETN and 50 percent TNT. Now that pentolite, once readily available and inexpensive, is becoming increasingly difficult to acquire, other explosives may be utilized. Before their use the following conditions shall be met:

- a. Develop or cite data that shows that the candidate substitute is similar in burning rate and explosive force.
- b. Demonstrate through comparative testing that the candidate explosive produces similar results when used in explosion testing equivalent test plate blanks, and
- c. Submit to NAVSEA for approval and retain the supporting data on file in an engineering technical report form.

L.9.3.4 Explosive Charge Weight Selection. For explosion bulge testing, charge weights and standoff distances shall be selected to achieve an approximate 3 percent reduction in test specimen thickness (near the center, see L.9.2.2) for each shot. The following pentolite charge sizes shall be used for the following materials and thicknesses:

Material	Nominal Thickness (inches)	Nominal Charge Size (inches)	Nominal Pentolite Charge Weight (pounds)
HY-130	2	10 diameter by 10 height	42
HY-100	2	10 diameter by 7.3 height	30
HY-80	2	10 diameter by 6 height	24
HY-80	1	7 diameter by 3.5 height	7

Other testing shall have either the type and charge weight, or the expected surface strain, rate, and reduction in thickness specified for each shot. When charge size and weight is not specified, test work will be conducted to establish required explosion charge size and standoff distance to achieve the required surface strain and reduction in thickness for each explosive loading (shot). For explosion tear testing, where the specimen over the explosion die cavity is required to be uniformly loaded, flat sheet explosive such as DETA sheet has been found to be an effective explosive.

L.9.3.5 Crack Description. After each shot the test specimen shall be examined, and the location, length, and direction of all cracks recorded both by a written and sketch description (see [Figure L-12](#)). The Explosion Testing Record Form shown on [Figure L-13](#) shall be completed following each explosion test. Depending on the type of test being conducted, either reduction in thickness measurements or surface strain measurements shall also be recorded. Unless otherwise specified, measurements of plate thickness reductions shall be taken at the locations identified for measurements (see L.9.2.2 and [Figure L-4](#) and [Figure L-10](#)).

L.9.3.5.1 Reduction in Thickness Measuring Devices. [Figure L-10](#) shows two methods of measuring the reduction in thickness of the test specimen. The deep throat caliper shall be maintained in accordance with MIL-STD-45662. The ultrasonic gauging equipment shall meet the qualification requirements of T9074-AS-GIB-010/271. The ultrasonic gauging equipment shall be calibrated with two blocks (minimum) of known thickness (± 0.001 inch) and of the same nominal composition and condition as the plate to be gauged. One block shall be above the maximum thickness to be measured and one shall be below the minimum thickness to be measured. The minimum precision of the ultrasonic readings shall be 0.005 inch. Regardless of the method used by the authorized Government laboratory, the basis for selection shall be justified by demonstrating its accuracy over the full range of expected test assembly configuration (measurements on actual bulged test specimens). This information shall be documented and made available to NAVSEA on request (see L.10.2).

L.9.3.6 Successive Explosive Loadings. Before each successive shot, the test specimen shall be returned to the cooling medium long enough to thermally recondition the test specimen to obtain the required temperature and equilibrate as specified in L.9.3.1.2. Succeeding shots shall be fired using the same sequence described above and the results recorded. The number of shots required shall be that necessary to obtain the required surface strain minimum or percent reduction in thickness minimum (based on average of both measuring locations) specified in the applicable material specification. If failure occurs as specified in [Table L-1](#) before obtaining the required reduction in thickness, testing shall be terminated on the involved test specimen.

L.10 NOTES.

L.10.1 Intended Use. This appendix covers explosion testing used to evaluate ferrous and nonferrous base materials, plates, castings, forgings, welding filler metals, and welding procedures as required by applicable purchase specifications or fabrication documents.

L.10.2 Consideration of Data Requirements. The following data requirements should be considered when this standard is applied on a contract. The Data Item Description (DID) should be reviewed in conjunction with the specific acquisition to ensure that only essential data are requested/provided and that the DID is tailored to reflect the requirements of the specific acquisition. To ensure correct contractual application of the data requirements, a Contract Data Requirements List (DD Form 1423) must be prepared to obtain the data, except where DoD FAR Supplement 27.475-I exempts the requirement for a DD Form 1423.

Reference Paragraph	DID Number	DID Title	Suggested Tailoring
L.9.3.5, L.9.3.5.1, and L.11	DI-MISC-80653	Test Reports	-----

The above DID was that cleared as of the date of this standard. The current issue of DOD 5010.12-L, Acquisition Management Systems and Data Requirements Control List (AMSDL), must be researched to ensure that only current, cleared DID's are cited on the DD Form 1423.

L.10.3 Other Crack Starter Geometries. Other crack starter geometries have been successfully employed besides the Hardex N type detailed herein. Some examples are:

- Electron beam welded crack starter beads embrittled by introducing aluminum in titanium explosion tear test specimens.
- Hardex N or equivalent deposited weld metal in a test specimen groove and mechanically notched lengthwise with respect to the embrittled deposit, and
- Fatigue cracks introduced into test specimens.

The above methods are considered special applications and, if required to be used for crack initiation, the details of the type will be provided by NAVSEA.

L.10.4 Subject Term (Key Word) Listing.

Bead, crack starter

Prolongation

T9074-BD-GIB-010/0300 Rev 2

Test, bulge

Test, tear

L.11 TEST REPORT TECHNICAL CONTENT REQUIREMENTS.

L.11.1 Scope. This section covers the technical requirements that should be included in test reports when required by the contract or order. This section is mandatory only when data item description DI-MISC-80653 is cited on the DD Form 1423.

L.11.2 Test Reports. When required by the contract or order, test reports shall contain the results of the mechanical and explosion tests in an engineering technical report format and shall include an analysis of the test results. Where test failures occur, the report analysis shall address the cause for failure. The report text shall be supplemented by photographs, sketches, and other illustrations to assist in defining clearly the tests conducted, and the results obtained (see L.10.3).

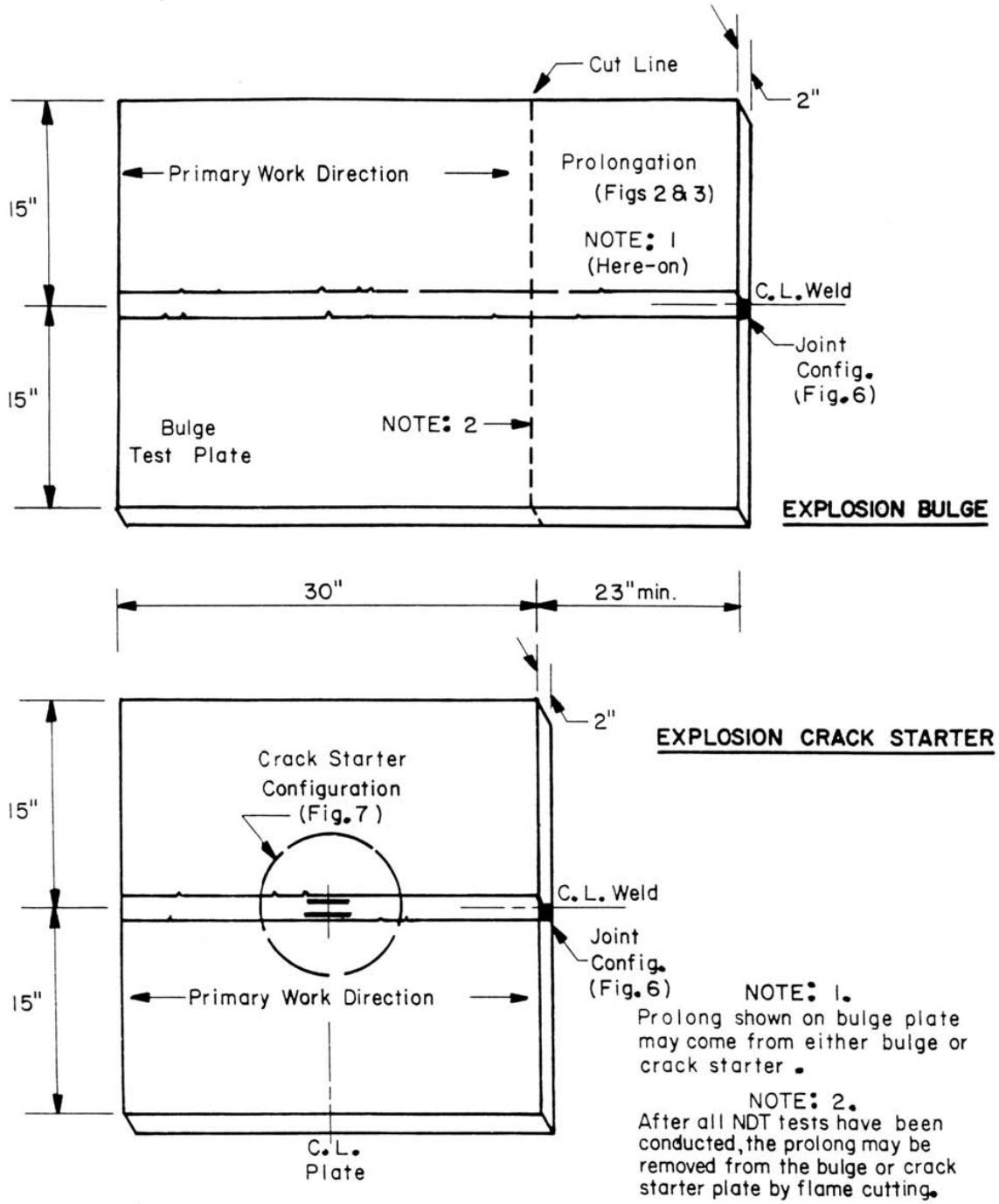

Figure L-1. Explosion Test Specimen Configuration.

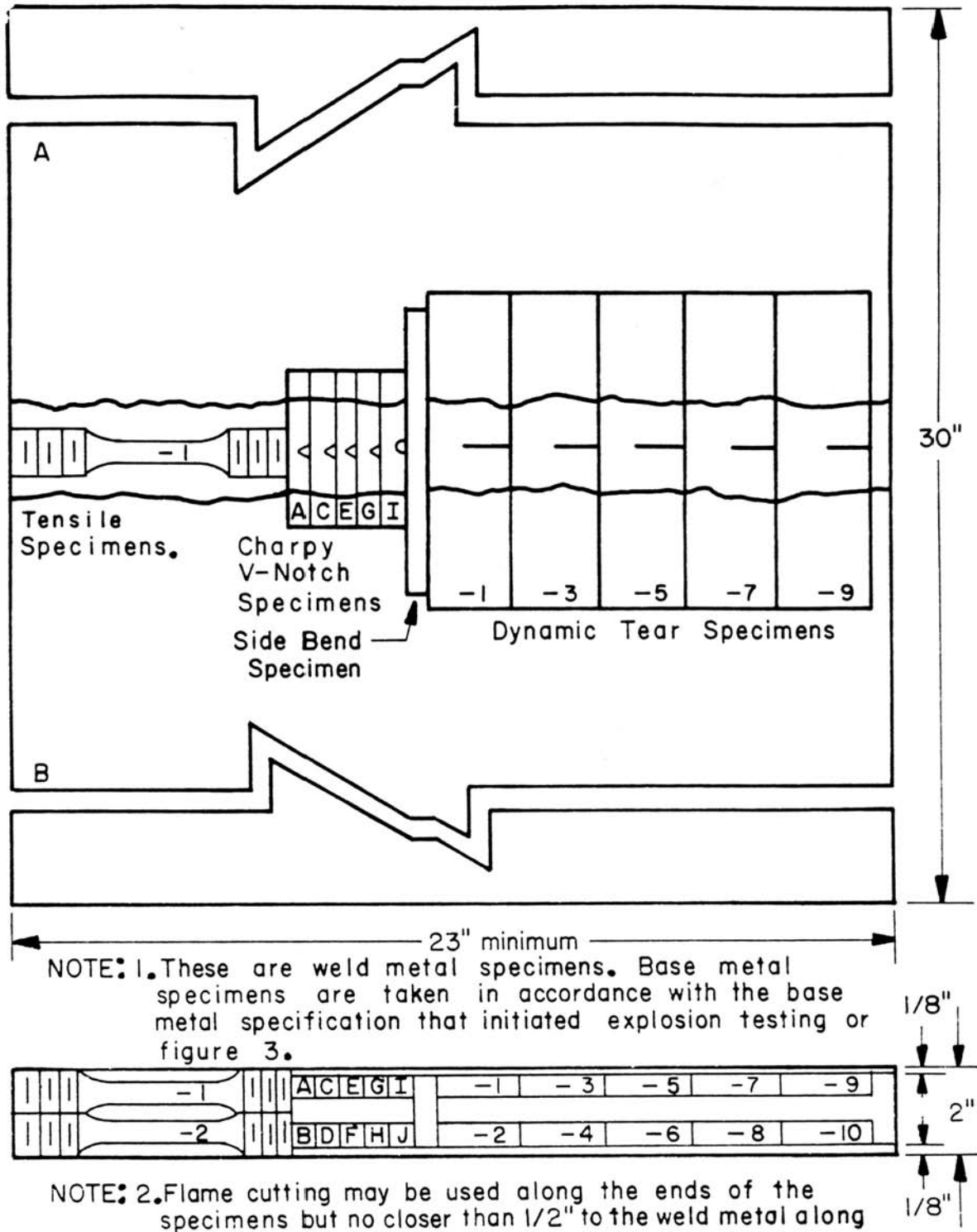
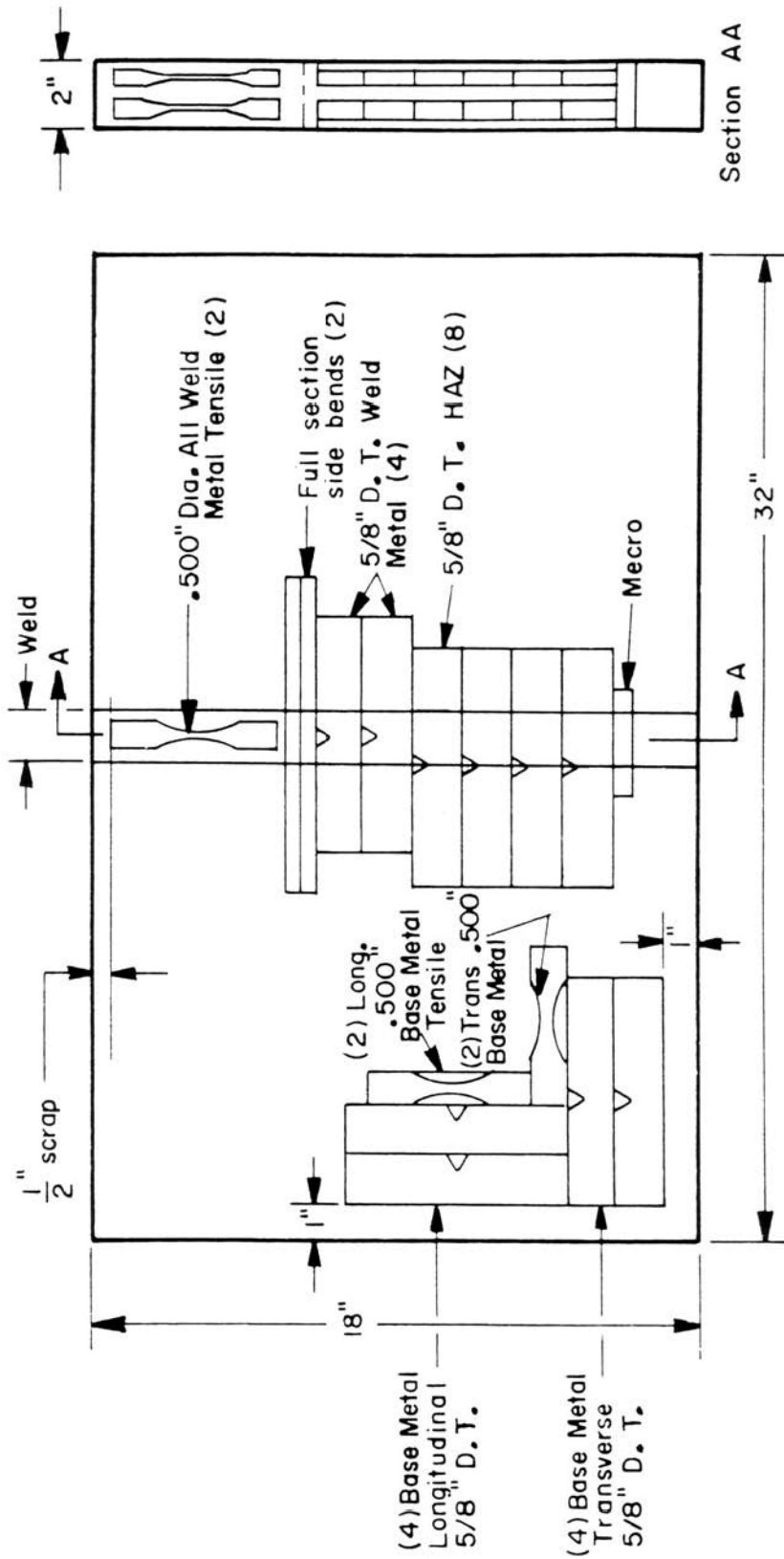

Figure L-2. Diagram of a Typical Mechanical Removal Orientation.



NOTE: This figure specifies where test specimens are to be removed relative to the orientation of the plate. The applicable material specification specifies the type and quantity of specimens required.

Figure L-3. Prolongation Mechanical Property Specimen Layout for Preproduction Qualification Testing.

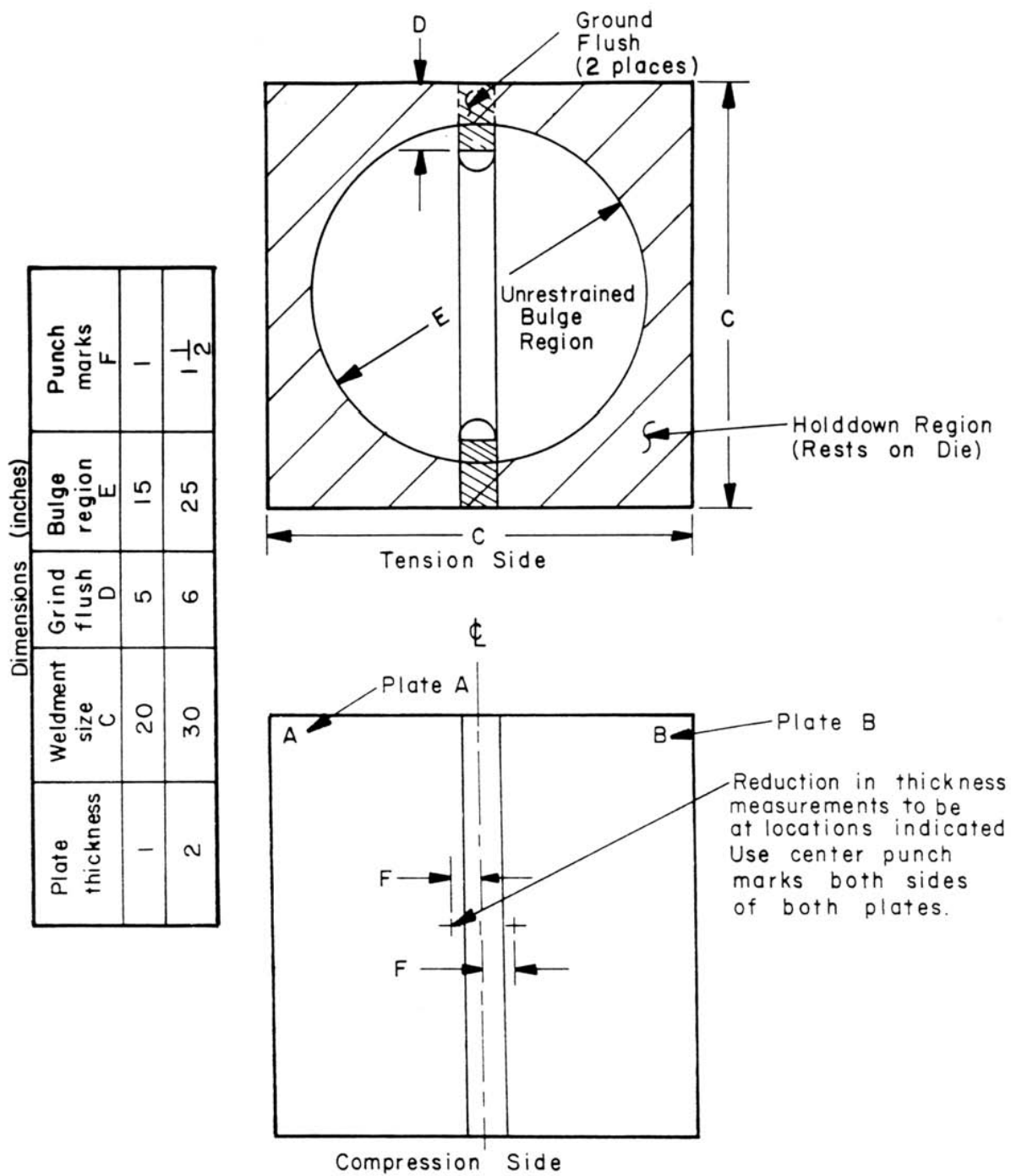

Figure L-4. Explosion Test Plate Preparation.

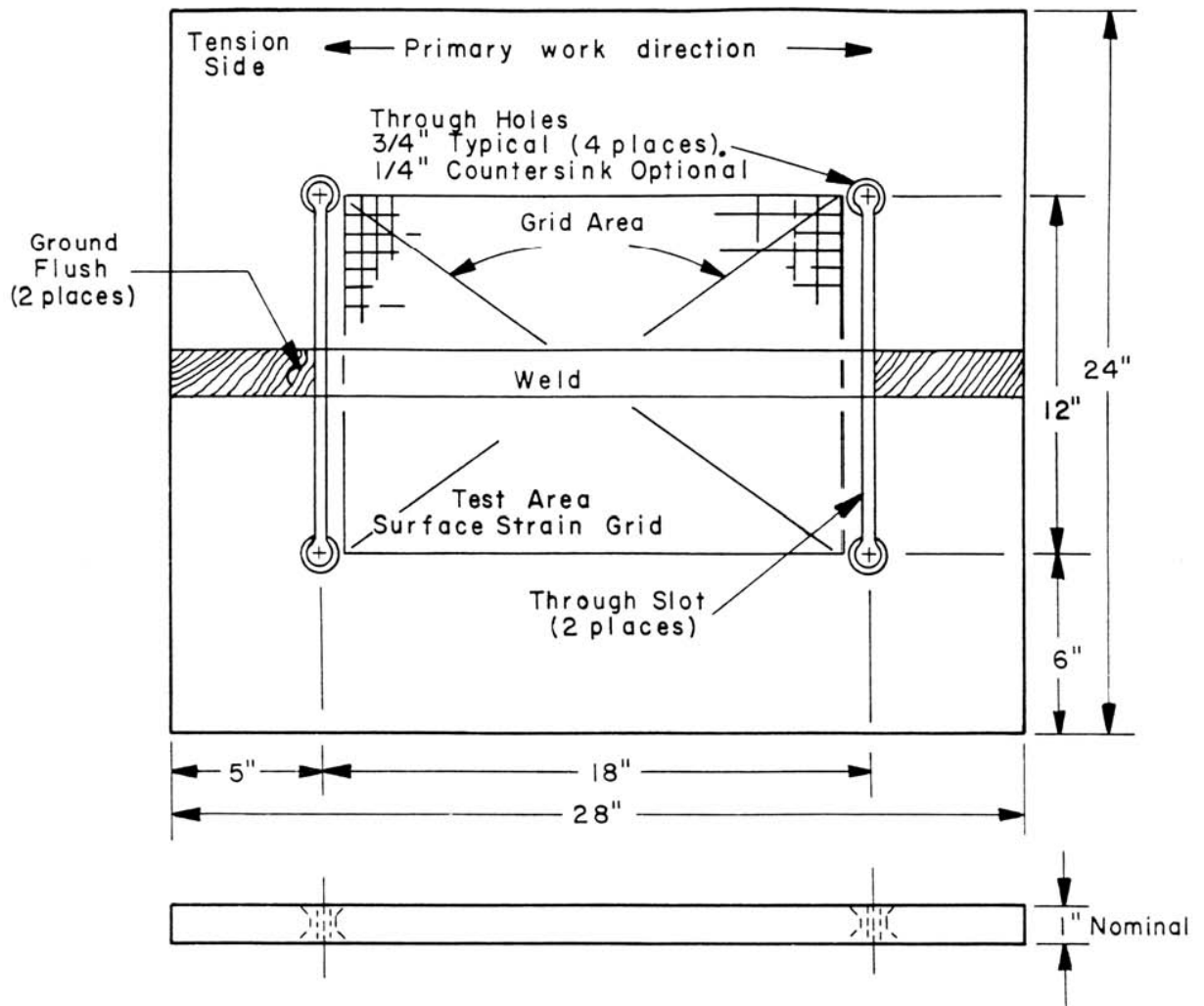

Figure L-5. Explosion Tear Test Weldment.

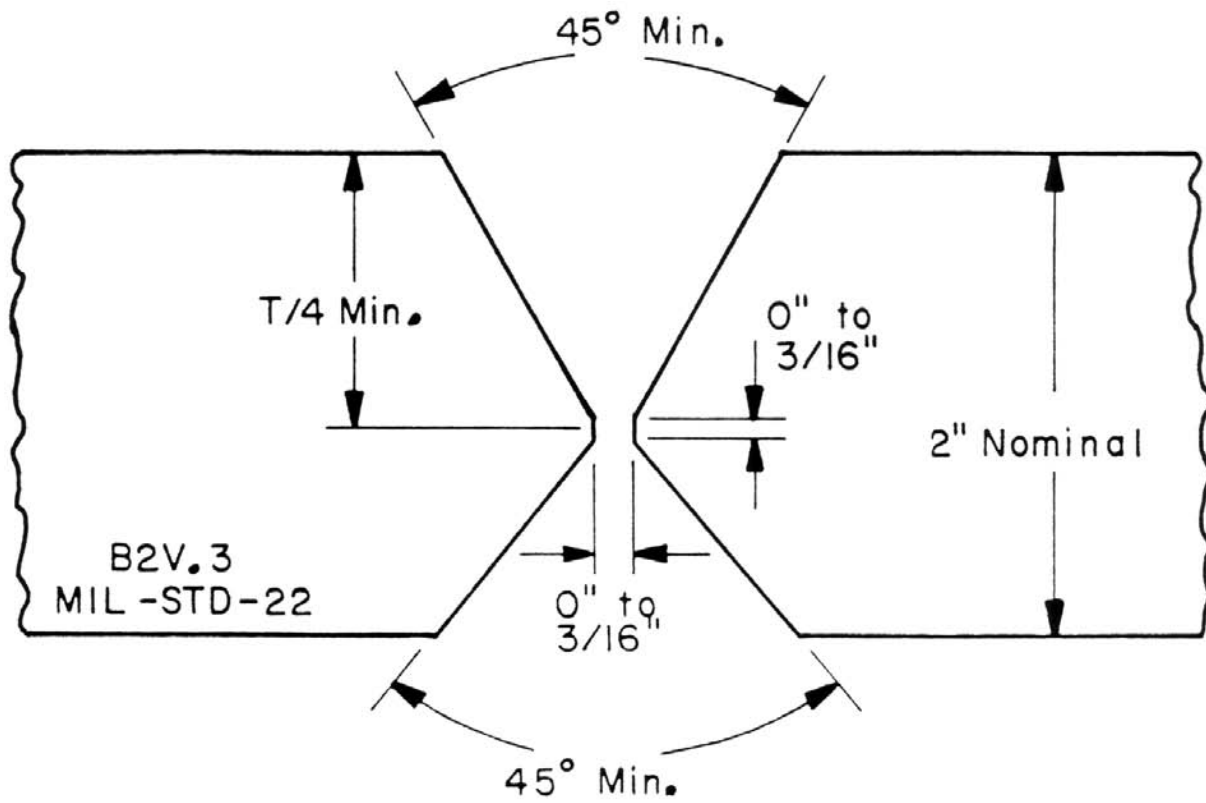

Figure L-6. Typical Configuration for Explosion Test Weldments.

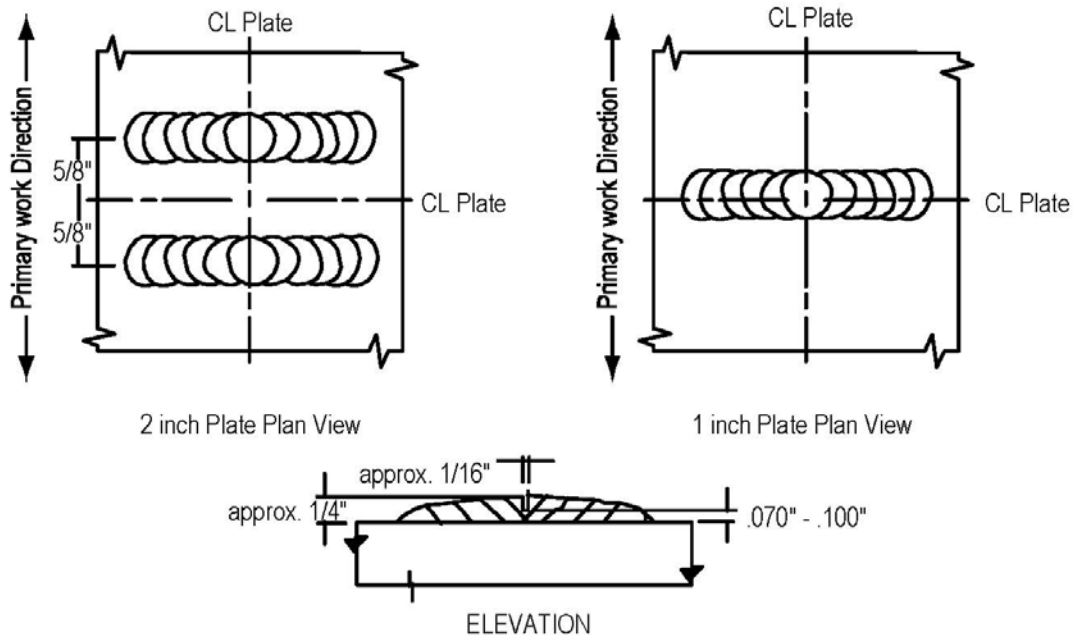

Figure L-7. Crack Starter Bead Configuration – Base Metal Evaluation Without a Weld Joint.

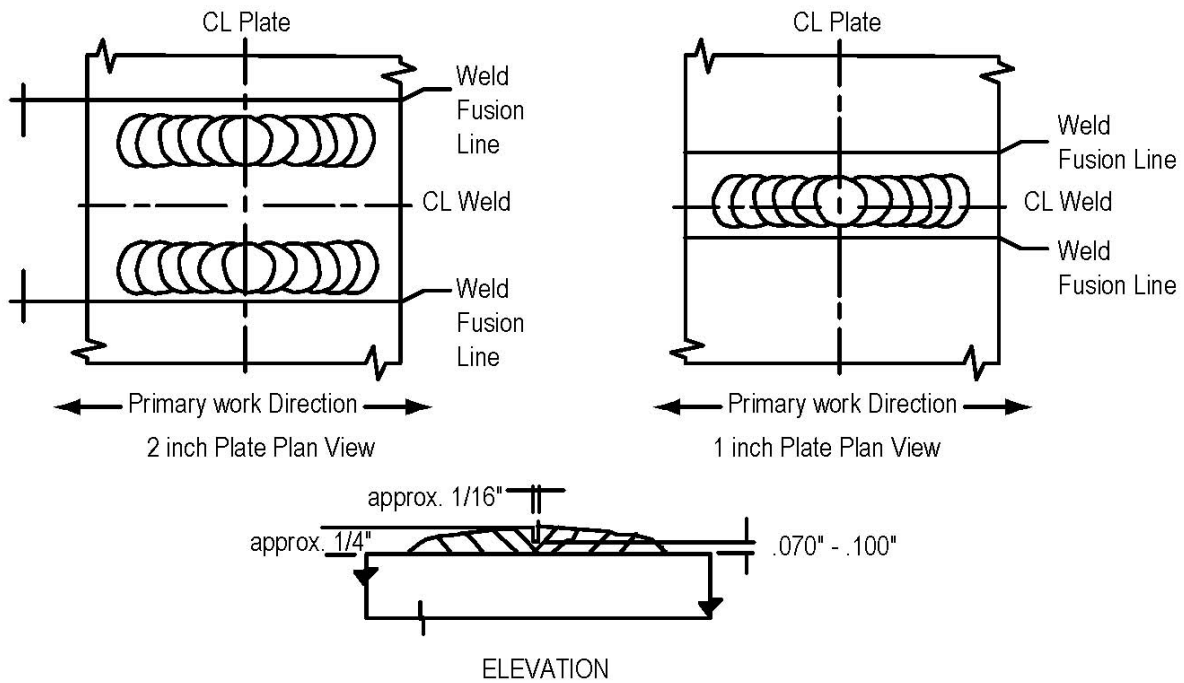

Figure L-8. Crack Starter Bead Configuration – Base Metal Evaluation Incorporating a Weld Joint.

T9074-BD-GIB-010/0300 Rev 2

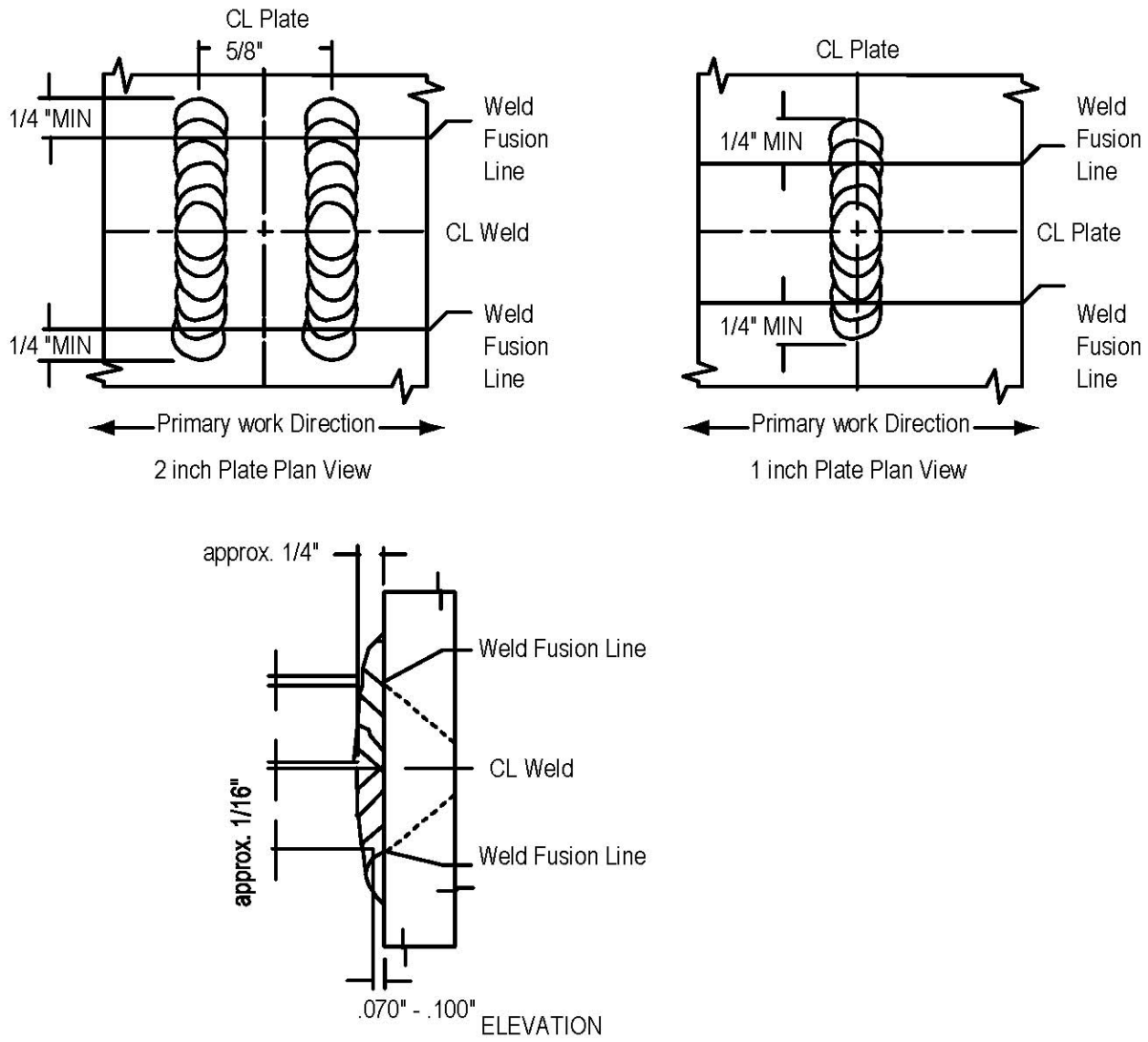

Figure L-9. Crack Starter Bead Configuration – Weld Metal and Weld Procedure Evaluation.

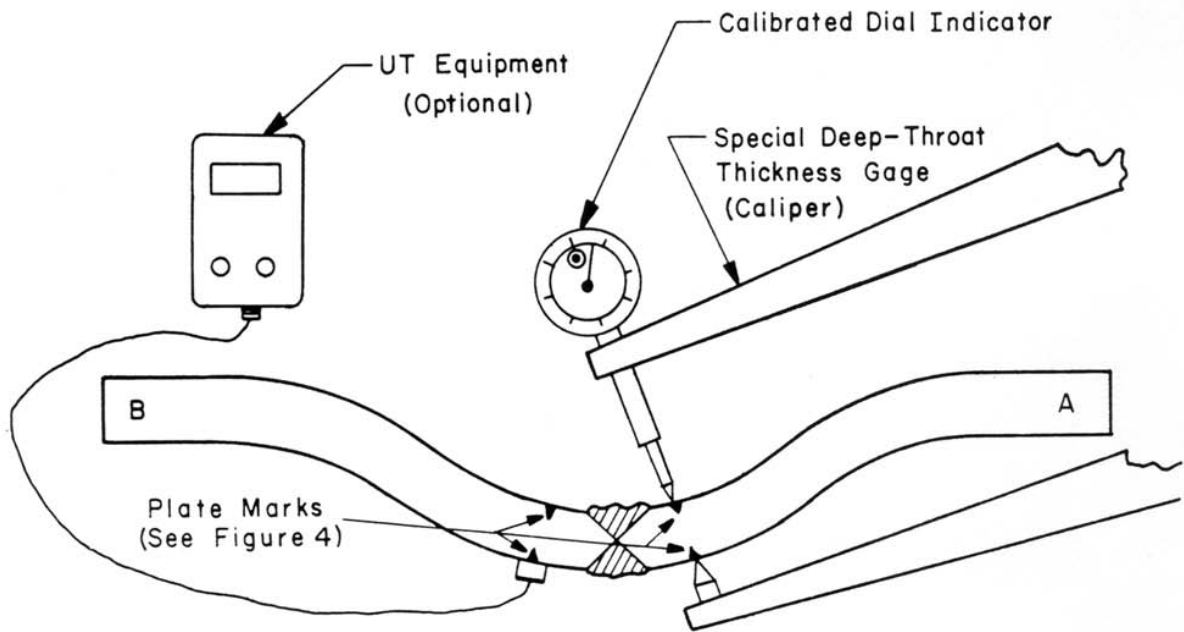

Figure L-10. Explosion Test Measurements.

T9074-BD-GIB-010/0300 Rev 2

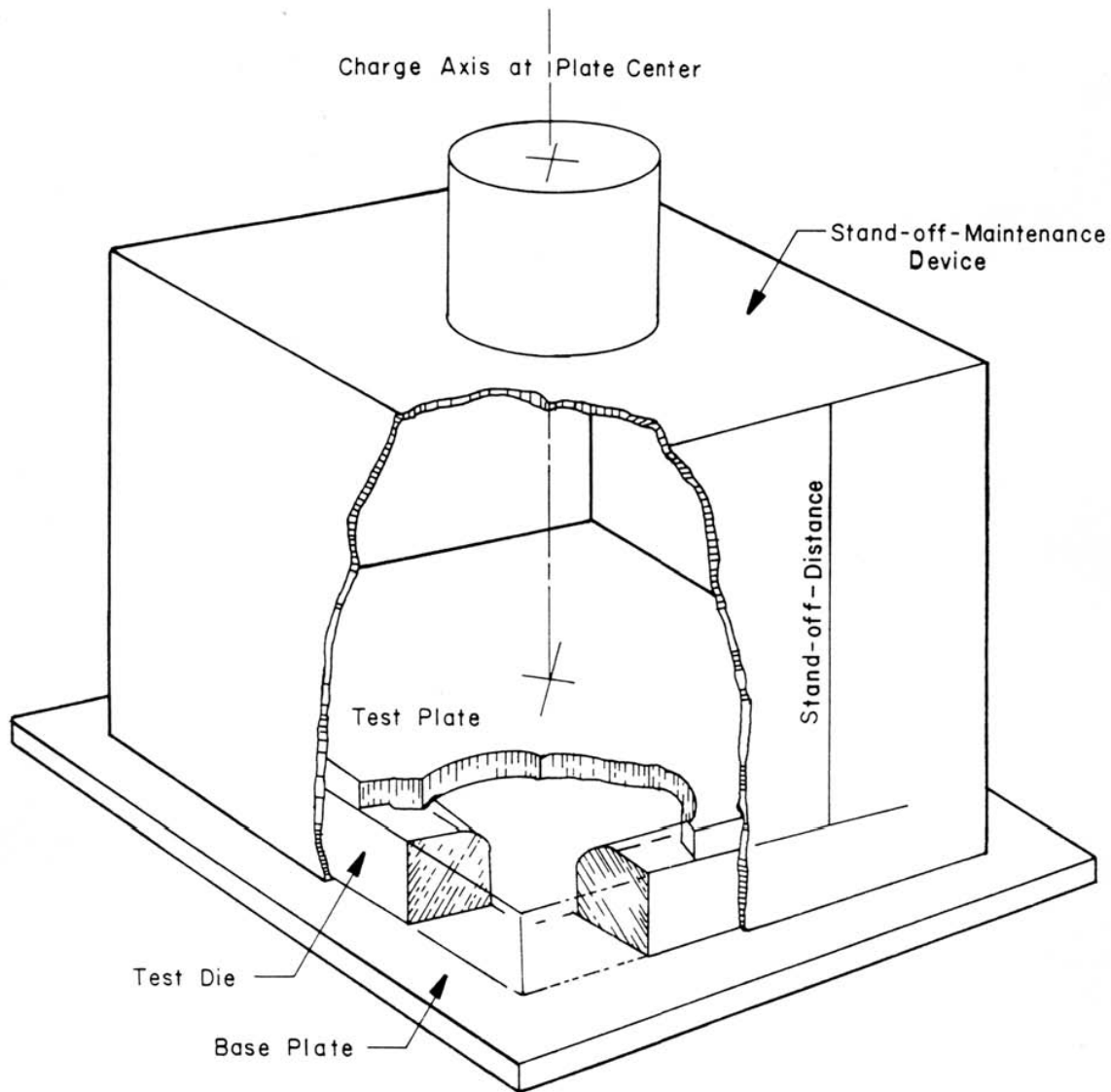

Figure L-11. Explosion Test Configuration.

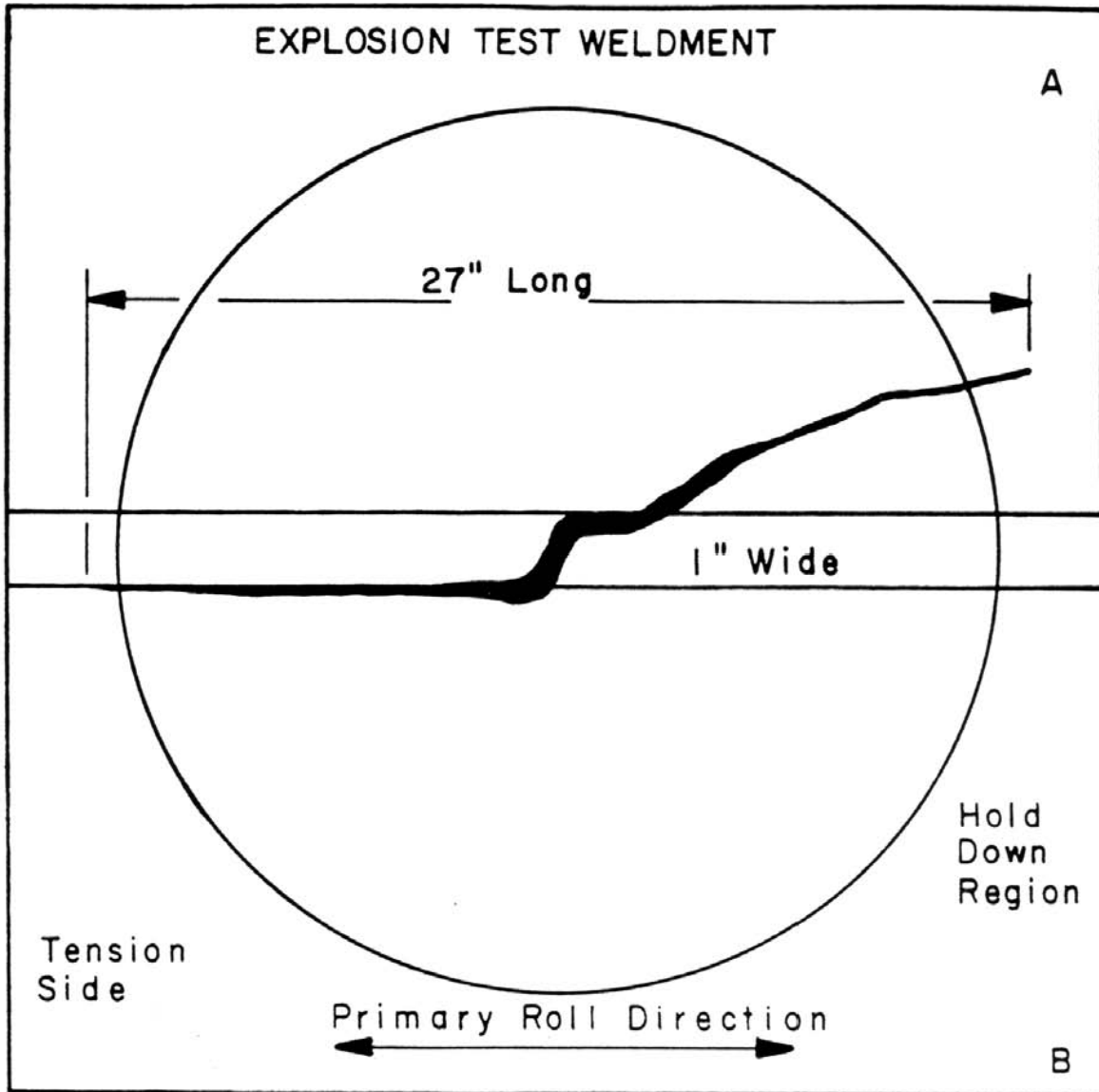

Figure L-12. Typical Fracture Sketch of Explosion Test Weldment.

EXPLOSION TESTING RECORD													
EXPLOSION TESTING RECORD			PROCESS:			ELECTRODE TYPE AND SIZE:			DATE:				
PLATE IDENTIFICATION NO. :			COOLING MEDIUM:			TEST TEMPERATURE AND % REDUCTION SPECIFIED:			<input type="checkbox"/> CRACK STARTER <input type="checkbox"/> EXPLOSION BULGE				
STAND-OFF DISTANCE:			PLATE THICKNESS PRIOR TO SHOT:			"A" _____			"B" _____				
PLATE SIDE IN TENSION:			EXPLOSIVE CHARGE TYPE, SIZE, AND WEIGHT			AMB TEMP			REMARKS				
SHOT NO.	DATE	NORMALIZING			BATH TO SHOT			THICKNESS		% OF REDUCTION			
		START TIME	EXIT TIME	TOTAL TIME	EXIT TEMP	SHOT TEMP	TOTAL TIME	A	B	A	B		
1													
2													
3													
4													
5													
6													
7													
8													

NOTES:

Figure L-13. Sample Explosion Testing Record.

APPENDIX M SUPPLEMENTAL TECHNICAL REQUIREMENTS TO ISO 9001:2000

M.1 SCOPE.

M.1.1 Scope. This appendix identifies the supplemental technical requirements that shall be added to the quality management systems requirements of ISO 9001:2000 when the latter standard is specified for procurement of the base materials covered by this Technical Publication.

M.2 APPLICABLE DOCUMENTS.

See Chapter 2.

M.3 REQUIREMENTS.

M.3.1 Supplemental Requirements. The following supplemental requirements shall be added to the requirements of ISO 9001:2000.

M.3.1.1 Organization Quality System.

- a. Add to ISO 9001:2000, Paragraph 4.1 - General requirements.

The organization shall provide and maintain a quality assurance program that ensures that the product meets the contract requirements and that is acceptable to Customer and Government. The organization shall notify the customer in writing of any change, other than editorial, to the quality manual.

M.3.1.2 Coordinated Government/Organization Actions and Use of Organization Inspection Facilities.

- a. Add to ISO 9001:2000, Paragraph 7.4.2 - Purchasing information.

When, under authorization of the Government Representative, copies of the purchasing document are to be furnished directly by the supplier or organization to the Government Representative at his facility rather than through Government channels, the organization shall add to his purchasing document a statement substantially as follows:

“On receipt of this order, promptly furnish a copy to the Government Representative who normally services your plant. In the event the representative or office cannot be located, our purchasing agent should be notified immediately.”

All documents and referenced data for purchases applying to a Government contract shall be available for review by the Government Representative to determine compliance with the requirements for control of such purchases. Copies of purchasing documents required for Government inspection purposes shall be furnished in accordance with the instructions of the Government Representative.

- b. Add to ISO 9001:2000 Paragraph 7.4.3 - Verification of purchased product.

The organization shall make available to the Government Representative reports of any nonconformance found on Government source-inspected supplies and shall (when requested) require the organization to coordinate with his Government Representative on corrective action.

- c. Add to ISO 9001:2000, Paragraph 8.2.4 - Monitoring and measurement of product.

When required, the organization's measuring and testing equipment shall be made available for use by the Government Representative to determine conformance of product with contract requirements. In addition, if conditions warrant, organization's personnel shall be made available for operation of such devices and for verification of their accuracy and condition.

M.3.1.3 Sample Inspection.

- a. Add to ISO 9001:2000, Paragraph 8.1 - General.

Statistical techniques or sampling inspection procedures used for product acceptance shall be subject to approval by the customer.

T9074-BD-GIB-010/0300 Rev 2

M.3.1.4 Interpretation of Limits.

- a. Add to ISO 9001:2000, Paragraph 7.1 Planning of product realization.

Where not otherwise contractually invoked, all specified limits for machining services and for dimensional control of deliverable parts and assemblies shall be interpreted as absolute limits as defined by ASTM E29, Standard Practice for Using Significant Digits in Test Data to Determine Compliance with Specifications. Unless otherwise specified in the contract, for all other observed, measured, or calculated product characteristics (e.g., for material suppliers, material distributors, services other than machining) specified limits shall be interpreted using round-off method as defined by ASTM E29.

M.3.1.5 Electronic Signatures.

- a. Add to ISO 9001:2000, Paragraph 8.2.4 - Monitoring and measurement of product.

When signatures are required by contract and will be provided electronically, protection from unauthorized changes of recorded data shall be provided.

Ref: NAVSEAINST 4160.3 NAVSEA S0005-AA-GYD-030/TMMP			
NAVSEA/SPAWAR TECHNICAL MANUAL DEFICIENCY/EVALUATION REPORT (TMDER)			
INSTRUCTIONS: Continue on 8 1/2" x 11" on page if additional space is needed.			
1. Use this report to indicate deficiencies, problems and recommendations relating to publications.			
2. For CLASSIFIED TMDERs see OPNAVINST 5510H for mailing requirements.			
3. For TMDERs that affect more than one publication, submit a separate TMDER for each.			
4. Submit TMDERs at web site https://nsdsa.nmci.navy.mil or mail to: COMMANDER, CODE 310 TMDERs, NAVSURFWARCENDIV NSDSA, 4363 MISSILE WAY BLDG 1389, PORT HUENEME CA 93043-4307			
1. PUBLICATION NUMBER	2. VOL/PART	3. REV/DATE OR CHG/DATE	4. SYSTEM/EQUIPMENT ID
5. TITLE OF PUBLICATION			6. REPORT CONTROL NUMBER (6 digit UIC-YY-any four: xxxxxx-10-xxxx)
7. RECOMMEND CHANGES TO PUBLICATION			
7a. Page #	7b. Para #	7c. RECOMMENDED CHANGES AND REASONS	
8. ORIGINATOR'S NAME AND WORK CENTER		9. DATE	10. ORIGINATOR'S E-MAIL ADDRESS
11. TMMA of Manual (NSDSA will complete)			
12. SHIP OR ACTIVITY Name and Address (Include UIC/CAGE/HULL)		13. Phone Numbers:	
		Commercial () ___-___	
		DSN ___-___	
		FAX () ___-___	

FOLD HERE AND TAPE SECURELY
PLEASE DO NOT STAPLE

INCLUDE COMPLETE ADDRESS

USE
PROPER
POSTAGE

FOR OFFICIAL USE ONLY

**COMMANDER
CODE 310 TMDERs
NAVSURFWARCENDIV NSDSA
4363 MISSILE WAY BLDG 1389
PORT HUENEME CA 93043-4307**

FOLD HERE AND TAPE SECURELY
PLEASE DO NOT STAPLE