

802-8979757

REVISION 0

PROJECT PECULIAR DOCUMENT

**DIRECTED ENERGY DEPOSITION
ADDITIVELY MANUFACTURED BASE METALS
FOR CRITICAL APPLICATIONS:
REQUIREMENTS FOR GAS METAL ARC WELDING
ADDITIVELY MANUFACTURED PRE-FORMS
FOR LOW-ALLOY STEEL APPLICATIONS**



DISTRIBUTION STATEMENT A: APPROVED FOR PUBLIC RELEASE.

PUBLISHED BY DIRECTION OF COMMANDER, NAVAL SEA SYSTEMS COMMAND

DD MONTH YYYY

802-8979757

RECORD OF REVISIONS

REVISION NO.	DATE	TITLE OR BRIEF DESCRIPTION/PREPARING ACTIVITY
0	DD MON YYYY	Initial issue.

FOREWORD

This document is intended to cover the general requirements, quality assurance provisions, test procedures, and instructions for preparation and delivery of high-strength steel directed energy deposition (DED) additively manufactured pre-forms.

TABLE OF CONTENTS

Chapter/Paragraph	Page
Chapter 1 Scope	1-1
1-1 Scope.....	1-1
1-2 Classification.....	1-1
Chapter 2 Applicable Documents	2-1
2-1 General.....	2-1
2-2 Reference Documents.....	2-1
2-2.1 Government Documents.....	2-1
2-2.2 Other Government Publications.....	2-1
2-2.3 Non-Government Publications.....	2-2
2-2.4 Order of Precedence.....	2-2
2-3 Definitions.....	2-2
Chapter 3 Requirements.....	3-1
3-1 Appendices.....	3-1
3-2 First Article.....	3-1
3-3 Material.....	3-1
3-3.1 Build Platform Material.....	3-1
3-4 Chemical Composition.....	3-1
3-5 Mechanical Properties.....	3-1
3-6 Rounding Properties.....	3-1
3-7 DED Additive Manufacturing Procedure.....	3-2
3-8 DED Additive Manufacturing Operators.....	3-2
3-9 Build Requirements.....	3-2
3-9.1 Build Prohibitions.....	3-2
3-9.2 Material Identification.....	3-2
3-9.3 Preheat and Interpass Temperature.....	3-2
3-9.3.1 Application of Preheat.....	3-2
3-9.3.1.1 Methods.....	3-2
3-9.3.1.2 Heating.....	3-3
3-9.3.1.3 Control of Heating (General).....	3-3
3-9.3.1.4 Control of Minimum Temperature.....	3-3
3-9.3.1.5 Control of Maximum Temperature.....	3-3
3-9.3.1.6 Torch Heating.....	3-3
3-9.3.2 Temperature Checks.....	3-3
3-9.3.2.1 Preheat Temperature Measurement.....	3-3
3-9.3.2.2 Interpass Temperature Measurement.....	3-3
3-9.4 Heat Input.....	3-4
3-9.4.1 Calculation of Heat Input.....	3-4

Chapter/Paragraph	Page
3-9.4.2 Consistency of Heat Input.....	3-4
3-9.5 Repairs.....	3-4
3-9.6 Instrumentation Records.....	3-4
3-10 Workmanship Requirements.....	3-4
3-10.1 Surface Preparation.....	3-4
3-10.1.1 Silicate Removal.....	3-4
3-10.2 Metal Spatter.....	3-5
3-11 Heat Treatment.....	3-5
3-11.1 Heat Treatment Equipment and Controls.....	3-5
3-11.2 Heat Treatment Record.....	3-5
3-11.3 Working Zone Temperature Survey.....	3-5
3-11.4 Load Distribution.....	3-5
3-11.5 Quenchant Temperature.....	3-5
3-11.6 Contact Thermocouples.....	3-6
3-12 Surface Quality.....	3-6
3-13 Dimensions and Tolerances.....	3-6
3-14 Identification and Marking.....	3-6
3-15 Descaling and Cleaning.....	3-6
3-16 Internal Soundness.....	3-6
3-17 Explosion Testing.....	3-6
Chapter 4 Verification.....	4-1
4-1 Responsibility for Inspection.....	4-1
4-1.1 Performance of Inspection.....	4-1
4-1.2 Examination of Material as Offered for Acceptance.....	4-1
4-1.3 Quality System.....	4-1
4-1.3.1 Traceability System.....	4-1
4-1.4 Product Quality Requirements.....	4-1
4-1.5 Responsibility for Compliance.....	4-1
4-1.6 Certification of Conformance.....	4-1
4-2 Classification of Inspections.....	4-2
4-3 First Article Inspection.....	4-2
4-3.1 Sampling for First Article Inspection.....	4-2
4-3.1.1 First Article Build Layouts.....	4-2
4-3.2 Process Control Plan.....	4-2
4-3.3 Process Control Plan Contents.....	4-3
4-3.3.1 Personnel Training Plan.....	4-3
4-3.3.2 Maintenance Control Plan.....	4-4
4-3.3.3 Digital File Handling Procedure.....	4-4
4-3.3.4 Feedstock Material Handling, Storage, and Control Procedure.....	4-4

Chapter/Paragraph	Page
4-3.3.5 Build Procedure.....	4-5
4-3.3.6 In-Process Monitoring and Control Plan.....	4-5
4-3.4 Re-Certification of First Article Approval.	4-5
4-4 Conformance Inspection.	4-6
4-4.1 Lot Definitions.....	4-6
4-4.1.1 Lot for Chemical Composition.....	4-6
4-4.1.2 Lot for Tension Tests.	4-6
4-4.1.3 Lot for Impact Tests.	4-6
4-4.1.4 Lot for Examinations and Inspections.....	4-6
4-4.2 Sampling.....	4-6
4-4.2.1 Sampling for Examination.	4-6
4-4.2.2 Sampling for Chemical and Spectrographic Analysis.....	4-6
4-4.2.3 Sampling for Tension Testing.....	4-6
4-4.2.4 Sampling for Impact Testing.....	4-6
4-4.2.5 Marking of Test Specimens.	4-6
4-4.3 Examination.....	4-6
4-4.4 Verification of Feedstock and Build Platform Materials.....	4-6
4-5 Test Procedures.	4-7
4-5.1 Chemical and Spectrographic Analysis.....	4-7
4-5.2 Tension Test.	4-7
4-5.3 Charpy V-Notch Impact Test.	4-7
4-5.4 Dynamic Tear Impact Test.	4-7
4-5.5 Explosion Test.	4-7
4-6 Rejection and Retests.....	4-7
4-6.1 Reheat Treatment.....	4-8
4-6.2 Tension Retest.	4-8
4-6.2.1 Gauge Length Retest.....	4-8
4-6.3 Charpy V-Notch Retest.	4-8
4-6.4 Dynamic Tear Retest.	4-8
4-6.5 Defective Specimen/Replacement of Test Specimens.....	4-8
Chapter 5 Packaging.....	5-1
5-1 Preparation for Packaging and Packing.	5-1
5-2 Packaging, Packing, and Marking for Shipment.....	5-1
5-3 Packaging by Department of Defense (DoD) Personnel.....	5-1
Chapter 6 Notes.....	6-1
6-1 Intended Use.	6-1
6-2 Acquisition Requirements.....	6-1
6-3 First Article.	6-1
6-3.1 New Vendors.	6-1

Chapter/Paragraph	Page
6-3.2 Forwarding Data.....	6-1
6-3.3 Manufacturing and Testing.....	6-1
Appendix A Steel Gas Metal Arc Additively Manufactured Structure, Low-Alloy, High Yield Strength (100S GMAAM).....	A-1
A-1 Scope.....	A-1
A-1.1 Scope.....	A-1
A-1.2 Classification.....	A-1
A-2 Applicable Documents.....	A-1
A-3 Requirements.....	A-1
A-3.1 Material.....	A-1
A-3.2 Chemical Composition.....	A-1
A-3.3 Thickness Definition.....	A-1
A-3.4 Tensile Properties.....	A-2
A-3.5 Impact Properties.....	A-3
A-3.6 Additional Conformance Testing.....	A-5
A-3.7 Heat Treatment.....	A-5
A-3.7.1 Simulated Stress Relief.....	A-6
A-3.8 Explosion Performance.....	A-6
A-3.9 Cleaning.....	A-6
A-3.10 Internal and External Soundness.....	A-6
A-3.11 Repair of Defects.....	A-7
A-3.11.1 Minor Repairs.....	A-8
A-3.11.2 Nominal and Special Repairs.....	A-8
A-3.12 Dimensions and Tolerances.....	A-8
A-3.13 Markings.....	A-8
A-3.14 Hardness.....	A-8
A-3.15 Minimum Preheat Temperature.....	A-8
A-3.16 Minimum and Maximum Interpass Temperature.....	A-9
A-4 Verification.....	A-9
A-4.1 Responsibility for Inspection.....	A-9
A-4.2 Classification of Inspection.....	A-9
A-4.3 First Article Inspection.....	A-9
A-4.3.1 First Article Samples.....	A-9
A-4.3.1.1 GMAAM Pre-Forms.....	A-9
A-4.3.1.1.1 Capability and Feasibility of AM Design.....	A-10
A-4.3.1.2 Prolongation or Witness Coupons.....	A-10
A-4.3.1.2.1 For 100S-HT Pre-Forms.....	A-10
A-4.3.1.2.2 Prolongation or Witness Coupon Size.....	A-10
A-4.3.1.2.3 Prolongation or Witness Coupon Heat Treatment.....	A-11
A-4.3.1.2.4 Prolongation or Witness Coupon As-Printed Builds.....	A-11

Chapter/Paragraph	Page
A-4.3.1.3 Explosion Test Specimens.....	A-11
A-4.3.2 First Article Examinations and Tests.....	A-11
A-4.3.2.1 Examination.....	A-11
A-4.3.2.2 Test Specimen Location.....	A-11
A-4.3.2.2.1 Test Specimen Location in Sections Greater than 6 Inches.....	A-11
A-4.3.2.3 Chemical Analysis.....	A-12
A-4.3.2.4 Tensile Test.....	A-12
A-4.3.2.5 Charpy V-Notch Test.....	A-12
A-4.3.2.6 Dynamic Tear Test.....	A-12
A-4.3.2.7 Transition Test Curve.....	A-12
A-4.3.2.8 Explosion Test.....	A-12
A-4.3.2.9 Hardness Test.....	A-13
A-4.3.2.10 First Article Inspection Report.....	A-13
A-4.4 Conformance Inspection.....	A-13
A-4.4.1 Lot Definitions.....	A-13
A-4.4.1.1 Lot for Tensile and Impact Tests.....	A-13
A-4.4.1.2 Lot for Examination and Inspection.....	A-13
A-4.4.1.3 Lot for Chemical Composition.....	A-13
A-4.4.2 Sampling for Chemical Analysis.....	A-13
A-4.4.3 Sampling for Mechanical Tests.....	A-13
A-4.4.3.1 Sampling for Mechanical Tests Following Simulated Stress Relief.....	A-13
A-4.4.3.2 Sampling of Tensile Test.....	A-14
A-4.4.3.3 Sampling for Charpy V-Notch Tests.....	A-14
A-4.4.3.4 Sampling for Dynamic Tear Tests.....	A-14
A-4.4.4 Nondestructive Testing.....	A-14
A-4.4.4.1 Hardness Testing.....	A-14
A-4.5 Test Procedures.....	A-14
A-4.5.1 Chemical Analysis.....	A-14
A-5 Packaging.....	A-14
A-6 Notes.....	A-14
A-6.1 Intended Use.....	A-14
A-6.2 Acquisition Requirements.....	A-14
A-6.3 First Article.....	A-15
A-6.3.1 Receipt Inspection.....	A-15
Appendix B Supplemental Technical Requirements to ANSI/ASQ ISO 9001:2015.....	B-1
B-1 Scope.....	B-1
B-1.1 Scope.....	B-1
B-2 Applicable Documents.....	B-1
B-3 Requirements.....	B-1

Chapter/Paragraph	Page
B-3.1 Supplemental Requirements.	B-1
B-3.1.1 Organization Quality System.	B-1
B-3.1.2 Coordinated Government/Organization Actions and Use of Organization Inspection Facilities.	B-1
B-3.1.3 Sample Inspection.	B-2
B-3.1.4 Interpretation of Limits.....	B-2
B-3.1.5 Electronic Signatures.....	B-2
B-3.1.6 Documented Information.....	B-2
B-3.1.7 Corrective Actions.....	B-2

LIST OF TABLES

Table	Title	Page
Table A-1.	Chemical Composition (Weight Percent) ^{1/}	A-2
Table A-2.	Tensile Property Requirements.....	A-3
Table A-3.	Impact Property Requirements	A-4
Table A-4.	Nondestructive Inspection and Acceptance Criteria.....	A-7
Table A-5.	Local AM Shape Weld Repair and Heat Input Combination Limits.....	A-8
Table A-6.	First Article and Conformance Inspection Requirements.....	A-9
Table A-7.	Dimensions of Witness Coupons.....	A-10

LIST OF ILLUSTRATIONS

Figure	Title	Page
Figure 3-1.	Heat Treatment Procedure Information ^{1/, 2/}	3-7
Figure 3-2.	Information to be Documented on the Heat Treatment Record	3-8
Figure A-1.	Sample First Article GMAAM Shape	A-16
Figure A-2.	Schematic Diagram of Test Specimen Location for Castings Greater than 6 Inches in Thickness.....	A-18

CHAPTER 1 SCOPE

1-1 SCOPE.

This document covers the general requirements, quality assurance provisions, test procedures, and instructions for preparation and delivery of high-strength steel directed energy deposition (DED) additively manufactured (AM) materials. This material will typically require machining and/or other types of surface finishing prior to inspection, assembly, and use. It is intended that material produced to this document may be used as an alternative to NAVSEA T9074-BD-GIB-010/0300 HY-80 castings. This document does not supersede requirements for specific end-uses, which may impose additional requirements to those provided herein.

1-2 CLASSIFICATION.

High-strength steel DED AM pre-forms shall be furnished in the grades as specified in the appropriate appendix (see 6-2).

802-8979757

CHAPTER 2 APPLICABLE DOCUMENTS

2-1 GENERAL.

The documents listed in this Chapter are specified in Chapters 3 and 4 and Appendices A and B of this document. This Chapter does not include documents cited in other Chapters of this document or recommended for additional information or as examples. While every effort has been made to ensure the completeness of this list, document users are cautioned that they must meet all specified requirements of documents cited in Chapters 3 and 4 and Appendices A and B of this document, whether or not they are listed.

2-2 REFERENCE DOCUMENTS.

2-2.1 GOVERNMENT DOCUMENTS. The following specifications, standards, and handbooks form a part of this document to the extent specified herein. Unless otherwise specified, the issues of these documents are those cited in the solicitation or contract.

DEPARTMENT OF DEFENSE STANDARDS

MIL-STD-2035 - Nondestructive Testing Acceptance Criteria

(Copies of this document are available online at <https://quicksearch.dla.mil>.)

2-2.2 OTHER GOVERNMENT PUBLICATIONS. The following other Government documents, drawings, and publications form a part of this document to the extent specified herein. Unless otherwise specified, the issues of these documents are those cited in the solicitation or contract.

NAVAL SEA SYSTEMS COMMAND (NAVSEA) PUBLICATIONS

S9074-A4-GIB-010/AM-WIRE DED	- Requirements for Metal Directed Energy Deposition Additive Manufacturing
T9074-AD-GIB-010/1688	- Requirements for Fabrication, Welding, and Inspection of Submarine Structure
T9074-AS-GIB-010/271	- Requirements for Nondestructive Testing Methods
T9074-BC-GIB-010/0200	- Filler Materials for Critical Applications: Requirements for Flux-Cored Welding Electrodes, Bare Welding Electrodes and Fluxes, and Covered Welding Electrodes for Low-Alloy Steel Applications
T9074-BD-GIB-010/0300	- Base Materials for Critical Applications: Requirements for Low Alloy Steel Plate, Forgings, Castings, Shapes, Bars, and Heads of HY-80/100/130 and HSLA-80/100

(Copies of these documents are available online via Model Based Product Support (MBPS) at <https://mbps.navseaplms.navy.mil/Windchill/app/>. To gain access to MBPS, obtain an account with National Help Desk Service Management (NHDSM) at <https://nhdsm.navair.navy.mil> (a valid CAC is required to access this website) and submit a SAAR-N Request. Refer questions, inquiries, or problems to (888) 292-5919. These documents are available for ordering (hard copy) via the Naval Logistics Library (NLL) at <https://nll.navsup.navy.mil>. For questions regarding the NLL, contact the NLL Customer Service at nllhelpdesk@navy.mil, (866) 817-3130, or (215) 697-2626/DSN 442-2626.)

2-2.3 NON-GOVERNMENT PUBLICATIONS. The following documents form a part of this document to the extent specified herein. Unless otherwise specified, the issues of these documents are those cited in the solicitation or contract.

AMERICAN NATIONAL STANDARDS INSTITUTE (ANSI)

- ANSI/ASQ ISO 9001 - Quality Management Systems – Requirements
- ANSI/NCSL Z540-1 - Calibration Laboratories and Measuring and Test Equipment - General Requirements

(Copies of these documents are available online at <https://webstore.ansi.org>.)

ASTM INTERNATIONAL

- ASTM A370 - Standard Test Methods and Definitions for Mechanical Testing of Steel Products
- ASTM E29 - Standard Practice for Using Significant Digits in Test Data to Determine Compliance with Specifications
- ASTM E604 - Standard Test Method for Dynamic Tear Testing of Metallic Materials

(Copies of these documents are available online at www.astm.org.)

AMERICAN WEALDING SOCIETY (AWS)

- AWS A5.28/A5.28M - Specification for Low-Alloy Steel Electrodes and Rods for Gas Shielded Arc Welding
- AWS A5.32M/A5.32 - Welding Consumables – Gases and Gas Mixtures for Fusion Welding and Allied Processes

(Copies of these documents are available online at www.aws.org.)

SAE INTERNATIONAL

- SAE AMS-H-6875 - Heat Treatment of Steel Raw Materials

(Copies of this document are available online at www.sae.org.)

2-2.4 ORDER OF PRECEDENCE. In the event of a conflict between the text of this document and the references cited herein, the text of this document takes precedence. In the event of a conflict between Chapters 1 through 6 and the appendices, the appendices take precedence. Unless otherwise specified, any reference to a paragraph within this document includes all applicable sub-paragraphs. Nothing in this document, however, supersedes applicable laws and regulations unless a specific exemption has been obtained.

2-3 DEFINITIONS.

Terms related to AM shall be as specified in S9074-A4-GIB-010/AM-WIRE DED.

CHAPTER 3 REQUIREMENTS

3-1 APPENDICES.

The individual item requirements shall be as specified herein and in the applicable appendices. In the event of any conflict between the provisions of this document and the appendices, the latter shall govern.

3-2 FIRST ARTICLE.

Unless otherwise specified (see 6-2), a sample shall be subjected to first article inspection (see 4-3). A first article inspection report shall be prepared in accordance with the data ordering document included in the contract or order (see 6-3). Naval Sea Systems Command (NAVSEA) is the approval authority for the first article program and is responsible for initial qualification and recertification of vendors (see 4-3.4). Prior to the initiation of the first article production, a manufacturer shall submit a detailed qualification plan to NAVSEA for approval outlining the manufacturing processes and testing proposed to meet the requirements herein. The manufacturer shall also submit a Process Control Plan as specified in 4-3.3 for review for adequacy prior to the initiation of first article production.

3-3 MATERIAL.

Material covered by this document shall be made by the same process as that used to produce the first article test items with any specifically allowed amendments/revisions as specified herein. Process feedstock identified in the applicable appendix shall be classified and procured in accordance with the requirements of T9074-BC-GIB-010/0200. Shielding and cover gas classifications used during both DED AM first article and production shall be procured and conform to the requirements of AWS A5.32M/A5.32. A single lot of feedstock is required for each individual build (i.e., first article, component, part, etc.), unless otherwise approved by NAVSEA.

3-3.1 BUILD PLATFORM MATERIAL. Non-integral build platform material for as-printed DED AM components shall be of S-1 carbon steel, groups A, B, or C per table 13-1, Part I.B. of T9074-AD-GIB-010/1688, excluding those that are quenched and tempered. Procurement of the build platform material class or type shall be in accordance with the applicable document specified therein. A minimum of 1 inch of discardable AM build material shall separate the non-integral build platform from the final component's attached dimensional surface. Methods used to remove non-integral build platform material from the AM part shall not affect the mechanical properties of the AM part (e.g., band saw, water jet, EDM). Use of integrated build platform material with an as-printed DED AM build shall require NAVSEA approval. Integrated build platforms are prohibited for use in post-build heat-treated AM products, except that material deposited in accordance with an applicable appendix may have additional material deposited onto it in accordance with the same appendix prior to heat treatment.

3-4 CHEMICAL COMPOSITION.

The chemical composition of the AM product shall be as specified in the applicable appendix. The AM deposited material shall meet the alloy limits on chemical composition, elemental tolerance, and test procedures specified in the applicable appendix.

3-5 MECHANICAL PROPERTIES.

The material shall meet the mechanical properties (strength, elongation, Charpy V-notch, etc.) as specified in the applicable appendix.

3-6 ROUNDING PROPERTIES.

For purposes of determining conformance with this document, rounding rules shall be in accordance with ASTM A370.

3-7 DED ADDITIVE MANUFACTURING PROCEDURE.

An approved S9074-A4-GIB-010/AM-WIRE DED AM procedure shall be included in the first article inspection plan (see 3-2), unless otherwise approved by NAVSEA, maintained as part of the Procedure Control Plan, and referenced in the lot Conformance Inspection records.

3-8 DED ADDITIVE MANUFACTURING OPERATORS.

All DED Additive Manufacturing Operators shall be qualified in accordance with S9074-A4-GIB-010/AM-WIRE DED AM requirements, and receive training as outlined in the qualifying activity's Personnel Training Plan (see 4-3.3.1) and Workmanship Requirements (see 3-10) within its Procedure Control Plan.

3-9 BUILD REQUIREMENTS.

All DED AM material produced to this document shall be fabricated using qualified procedures and operators. In addition, the following build requirements shall apply and be addressed within the activity's Build Procedure, as applicable:

3-9.1 BUILD PROHIBITIONS. Unless specifically approved by NAVSEA, the following procedures are prohibited for DED AM:

- a. Gas metal arc short circuiting transfer (GMAW-short arc).
- b. Deposition in the vertical position, down progression.
- c. Deposition over galvanized or primer coated surfaces.
- d. Deposition on material when water, oil, or similar materials are in contact with the surface opposite the side of deposition.
- e. Outdoor manufacturing. DED AM shall be performed indoors in a dry environment shielded from drafts.
- f. Interlayer temperature-controlled deposition for as-printed material conditions.
- g. Temperature indicating crayons for preheat and interpass temperature measurements.
- h. Stress relief of as-printed builds.
- i. Active cooling for as-printed builds.

3-9.2 MATERIAL IDENTIFICATION. The build platform, feedstock, and shielding gas shall be positively identified.

3-9.3 PREHEAT AND INTERPASS TEMPERATURE. Preheat and interpass temperatures required for DED AM of low alloy steel are contained within the applicable appendix. The minimum preheat specified within the applicable appendix is to limit the possibility of hydrogen assisted cracking. Crack-free DED AM deposits shall be produced (as determined by required Nondestructive Test [NDT]) regardless of the actual preheat temperature used.

3-9.3.1 Application of Preheat.

3-9.3.1.1 Methods. Preheat shall be applied by any of the following methods used either singly or in combinations:

- a. Resistance heaters.
- b. Radiant and infrared heaters.
- c. Electrical induction.
- d. Soft gas torch (gas-air).
- e. Oxy-fuel torch.

f. Other methods as approved by NAVSEA.

3-9.3.1.2 Heating. The heating shall be of the uniform soaking type, applied preferably by means of electric heaters (resistance or induction) uniformly distributed on or around the area being additively manufactured. The spacing and wattage of heaters shall be such as to ensure that the entire build area is maintained within the required temperature range.

3-9.3.1.3 Control of Heating (General). Control of heating shall be maintained during the build process in order to minimize the risk of thermal stresses and damage to the material. Control of the required temperature range during the build process may be accomplished by distribution of deposition passes within the layer path plan and build sequence. Cyclic heating and the occurrence of temperature differentials greater than 100 °F along the deposition surface during the build process should be avoided to maintain thermal expansion and contraction stresses at a uniform level.

3-9.3.1.4 Control of Minimum Temperature. The minimum required temperature shall be established prior to depositing material. Loss of the minimum required temperature shall require reheating, as necessary, prior to resumption of the build process. If the interpass temperature drops below 100 °F, the portions of the partially completed pre-form requiring additional printing shall be magnetic particle (MT) inspected in accordance with the applicable appendix.

3-9.3.1.5 Control of Maximum Temperature. The maximum required temperature shall be checked as specified in 3-9.3.2. If at any time during the build process (except during deposition), the metal temperature is found to be above the maximum preheat and interpass temperatures specified in the applicable appendix, the build area shall be allowed to cool to within the required temperature prior to any subsequent deposition.

3-9.3.1.6 Torch Heating. When torch heating is used, the build shall be brought up to preheat temperature with sufficient time allowed for the heat to soak through the thickness. Torch heating shall be applied in all directions to best achieve a uniform soak. When torches are used for low temperature (60 to 125 °F) preheating, moisture condensate caused by the flame may occur on the build surface. This moisture shall be removed by maintaining metal temperature above ambient temperature until the surface is warm and dry to the touch.

3-9.3.2 Temperature Checks. Preheat temperature shall be checked prior to start of deposition or after a loss of preheat. Interpass temperature shall be checked during deposition between passes and layers, or only layers depending on qualified deposition strategy and appendix-specific requirements. Surveillance of preheat and interpass temperatures shall be in accordance with operator workmanship requirements. Temperatures of 125 °F and above shall be checked using temperature measuring devices. When the ambient temperature is below the required temperature or there is evidence of moisture on the material surface, preheat shall be applied until the area is dry and warm to the touch. Otherwise, no check of material temperature is required.

3-9.3.2.1 Preheat Temperature Measurement. Preheat temperature shall be measured on the surface of the build platform or build surface (if in process) to ensure a uniform temperature.

3-9.3.2.2 Interpass Temperature Measurement. Interpass temperature for bead-by-bead deposition shall be measured on the build surface along the entire length of each bead path prior to printing. Measurements shall be made within 1 inch on either side of the bead path center line. Reported interpass temperature values shall be taken from each deposited bead at its starting location. Interlayer temperature measurements for a layer-by-layer build strategy shall ensure the entire build surface is below the qualified maximum interpass temperature.

3-9.4 **HEAT INPUT.** Production minimum and maximum heat input limits shall be bound by those reported during first article inspection, supported by the DED AM procedure qualification data limits of wall (block) thickness and minimum and maximum preheat and interpass temperatures.

3-9.4.1 **Calculation of Heat Input.** Heat input shall be determined by a or b for non-waveform-controlled welding, or by b for waveform-controlled welding of arc-based processes as follows:

- a. Heat input [joules per inch] =
$$\frac{\text{voltage} * \text{amperage} * 60}{\text{travel speed [inches per minute]}}$$
- b. Heat input determined using instantaneous energy or power by:
 - (1) For instantaneous energy measurements in joules:

$$\text{heat input [joules per inch]} = \frac{\text{energy [joules]}}{\text{weld bead length [inches]}}$$
 - (2) For instantaneous power measurements in joules per second or watts:

$$\text{Heat input [joules per inch]} = \frac{\text{power} \left[\frac{\text{joules}}{\text{second}} \text{ or watts} \right] * \text{arc time [seconds]}}{\text{weld bead length [inches]}}$$

3-9.4.2 **Consistency of Heat Input.** The average heat input, based on each deposited bead, shall be provided in the first article inspection report and certificate of conformance. The average heat input shall be reported along with the sample's ± 2 standard deviations (i.e., 95 percent confidence level) and number of beads. All bead heat input values shall fall within the limits demonstrated during first article inspection and the qualified DED AM procedure heat input range (see 3-9.4). Requests for NAVSEA approval of deviations shall include a listing of nonconforming heat input beads and the locations of those beads within the build (e.g., a heat map CAD overlay, etc.), including existing test data or additional conformance testing needed to confirm the mechanical properties are acceptable. Exclusion of heat input values from any beads shall be noted and shall require NAVSEA approval.

3-9.5 **REPAIRS.** Repairs of the material shall be as specified in the applicable appendix.

3-9.6 **INSTRUMENTATION RECORDS.** Instrument calibration records shall be traceable to calibration performed in accordance with ANSI/NCSL Z540-1 or equivalent standard.

3-10 WORKMANSHIP REQUIREMENTS.

This section contains the requirements for workmanship practices and methods associated with DED additively manufactured parts in accordance with this document.

3-10.1 **SURFACE PREPARATION.** Build platform surfaces shall be prepared by machining operations (such as milling or grinding) to achieve a smooth surface finish. All build surfaces shall be free of:

- a. Paint or primer.
- b. Oil, grease.
- c. Moisture.
- d. Objectionable scale.
- e. Objectionable oxide or rust (such as weld soot).
- f. Objectionable nicks, gouges, and irregularities.
- g. Zinc, galvanizing, or thermal spray aluminum.
- h. Excess silicate.

3-10.1.1 **Silicate Removal.** Silicates formed during the DED process shall be removed to, at a minimum, the extent necessary that they do not interfere with metal deposition or required NDT.

3-10.2 **METAL SPATTER.** All metal spatter greater than 1/8-inch diameter shall be removed from DED AM surfaces to be used in the as-printed surface condition.

3-11 HEAT TREATMENT.

For heat-treated DED AM steel, heat treatment shall be defined as any of the following processes: homogenization/normalization, austenitization, quenching (in any medium), tempering, precipitation hardening, stress relief, and hydrogen soak. Heat treatment shall be in accordance with SAE AMS-H-6875 and as specified below and in the applicable appendix, unless otherwise determined to be acceptable by NAVSEA and documented in the Process Control Plan.

3-11.1 **HEAT TREATMENT EQUIPMENT AND CONTROLS.** Continuous or automatic heat-treating equipment may be employed provided such equipment produces heat-treated material that meets the requirements specified herein. The furnaces and temperature recording equipment shall be shown to correlate with the actual temperature of the material and shall be maintained and calibrated on a regularly scheduled basis in accordance with SAE AMS-H-6875 or as permitted in 3-11. The temperature of the material shall be recorded during the heating and, if applicable, stress relieving cycles of the heat treatment. After the charge reaches the selected temperature control setting, the furnace shall maintain the temperature of the material at any point in the working zone within ± 25 °F.

3-11.2 **HEAT TREATMENT RECORD.** A complete record of the heat treatments applied, including stress relief, shall be maintained and a record of the heat treatment shall be prepared as part of the certification report. The heat treatment record shall include all the information presented on [figure 3-1](#) and [figure 3-2](#) and a verification of inspection record, unless otherwise indicated in an applicable appendix.

3-11.3 **WORKING ZONE TEMPERATURE SURVEY.** Working zone temperature surveys shall be in accordance with SAE AMS-H-6875 or as specified in 3-11. However, when specified (see 6-2), furnace working zone temperature surveys of batch-type furnaces shall be conducted with a typical, nominal, or simulated production load in the furnace.

3-11.4 **LOAD DISTRIBUTION.** In addition to requirements in applicable appendices, during heat treatment, the items shall be distributed and, when necessary, properly supported by fixtures to permit complete and uniform heat treatment, to minimize distortion, and to allow free circulation of protective atmosphere (when used) to each item. Prior to heat treatment, fixtures shall be visually inspected for foreign material. Foreign material shall be removed prior to heat treatment unless it is positively identified as a material that does not contain detrimental material. All fixture surfaces in contact with heat-treated items shall be manufactured from material that is not detrimental. To meet these requirements, 3-11.4.a through 3-11.4.e below shall apply:

- a. Items shall be placed only within the working zone dimensions that are determined as part of the 3-11.3 temperature survey.
- b. Items in the load shall contact only supporting fixtures, other furnace load items, or attached thermocouples.
- c. Through holes and blind holes shall not be blocked in a manner that would prevent entry of protective atmosphere (when used) or quenchant.
- d. Thermal expansion and distribution of the load shall be considered so that distortion of items is minimized.
- e. In gas or oil-fired furnaces, items shall be distributed to avoid localized heating by flame impingement.

3-11.5 **QUENCHANT TEMPERATURE.** When quenching (see applicable appendices) is required, the water temperature at the initiation of the quenching operation shall not exceed 80 °F.

3-11.6 CONTACT THERMOCOUPLES. Unless otherwise specified in the applicable appendices or unless specifically approved by NAVSEA based on data presented at first article approval, for batch type furnaces, a minimum of three thermocouples shall be attached to the furnace load. The hot junctions (or the caps of sheathed thermocouples) shall be in contact with the items.

3-12 SURFACE QUALITY.

Surface quality of the material shall be as specified in the applicable appendix.

3-13 DIMENSIONS AND TOLERANCES.

Dimensions and tolerances of the material shall be as specified in the applicable appendix.

3-14 IDENTIFICATION AND MARKING.

Identification and marking of the material shall be as specified in the applicable appendix.

3-15 DESCALING AND CLEANING.

Descaling and cleaning of the material shall be as specified in the applicable appendix.

3-16 INTERNAL SOUNDNESS.

Soundness of the material shall be as specified in the applicable appendix.

3-17 EXPLOSION TESTING.

Unless specified as “not required” in the applicable appendix, explosion testing is required and shall meet the requirements of T9074-BD-GIB-010/0300, Appendix L. Two explosion crack starter and four explosion bulge specimens are required, unless otherwise specified in the applicable appendix. Performance requirements shall be as specified in T9074-BD-GIB-010/0300, table L-1, with a minimum of 10 percent reduction in thickness for explosion bulge, unless alternate (or additional) requirements are specified in the applicable appendix.

- A. Procedure No. _____ Revision _____ Date _____
- B. Heat treatment facility _____
- C. Item material specification _____ Revision _____ Amend. _____ Interim Change _____
- D. Material: Composition _____ Type _____ Condition _____ Grade _____ Class _____
- E. Time and temperature:

Heat Treatment	Aim Temperature	Tolerance ^{1/}	Holding Time
Preheating			
Annealing			
Solution Treating			
Precipitation Hardening			
Austenitizing			
Tempering			
Stress Relieving			

* Includes temperature tolerance if the tolerance is other than ±25 °F (±14 °C).

- F. Will items be quenched? Yes _____ No _____ If yes, identify:
 - 1. Quenching method (e.g., immersion, spray, etc.) _____
 - 2. Quenching medium (include additives, if any) _____
- G.
 - 1. If not quenched, how are the items cooled? _____
 - 2. Cooling rate (if specified by the contract document) _____
- H. Working zone atmosphere:
 - 1. Type of atmosphere: _____
 - 2. Dew point (maximum): _____ °F or °C
 - 3. Temperature above which the dew point must be controlled if other than 600 °F (316 °C) _____
 - 4. Flow rate: _____ cubic feet per hour
 - 5. Vacuum – Maximum pressure: _____ torr (mm Hg) or _____ microns Hg.
 - 6. Type of inert gas backfill (if used): _____ Backfill dew point (maximum) _____ °F or °C

^{1/} Enter "NA" when an item does not apply.

^{2/} A single heat treatment procedure may cover more than one heat treatment process, provided that the required information for each process is clearly distinguished.

Figure 3-1. Heat Treatment Procedure Information ^{1/, 2/}

- A. Heat treatment facility _____
- B. Heat-treated items _____
- C. Lot numbers or serial numbers _____
- D. Heat treatment procedure used (including revision and date of revision) _____
- E. Date of heat treatment _____
- F. Time/temperature data (the original temperature chart or the original manually recorded data). Include a standard time interval, such as one hour, or the starting time and chart speed marked on the chart.
- G. Specific furnace(s) used: _____
- H. Method of thermocouple attachment (batch furnace only): _____
- I. Quenching Information
 - 1. Was the item quenched in accordance with the heat treatment requirements of the applicable appendix?
Yes ___ No ___
(If items were quenched, answer 2 through 14 below. If items are not quenched, answer 15 below.)
 - 2. Quenching method: immersion _____ spray _____
other (specify) _____
 - *3. Quenching medium: _____
Additives (generic type & amount) _____
 - 4. Approximate quench tank capacity: _____ gallons (liters)
 - 5. Approximate rate of flow to quench tank: _____ gallons/minute (liters/minute)
 - 6. Type, number, and locations of agitation devices in quench tank: _____

 - 7. Approximate flow rate of quench sprays: _____ gallons/minute (liters/minute)
 - 8. Maximum time interval between removal from the furnace and the start of quenching: _____ minutes
 - 9. Is the item quenched individually: Yes ___ No ___
 - 10. If items are not quenched individually, how many items are quenched simultaneously? _____
 - 11. Minimum time in quenchant: Hours _____ Minutes _____
 - 12. Quenchant temperature: _____ °F or °C at start, _____ °F or °C at completion
 - 13. Surface temperature of the thickest section when removed from quenchant (not required for items of uniform thickness quenched in water provided the minimum time in the quenchant is at least four minutes per inch of thickness):
_____ °F or °C
 - 14. Forgings over 2500 pounds: Fixtured during quenching: Yes ___ No ___
Orientation in quenching medium (a sketch or reference to a standard practice is acceptable). _____
 - 15. If not quenched, how are the items cooled? _____

Figure 3-2. Information to be Documented on the Heat Treatment Record

J. Furnace Information:

1. Furnace type(s):

Batch furnace _____ Salt bath _____ Type of salt _____

Vacuum furnace _____ Integral quench: Yes ___ No ___

Continuous furnace _____ Furnace fuel: _____

2. Method of preventing flame impingement: _____

K. Temperature measurement and control information:

1. Thermocouple information:

(a) How many thermocouples were used? Contact _____ Noncontact _____

(b) Describe the location of each thermocouple (may provide a sketch)

2. How was working zone temperature recorded?

Automatically _____

Manually _____ (Monitoring interval) _____

3. How was working zone temperature controlled?

Automatically _____

Manually _____ (Monitoring interval) _____

4. If manual temperature control was used, how was the temperature adjusted (may reference a written standard practice): _____

5. If thermocouples were not used, briefly describe the type, number, and location of the temperature measuring devices used to indicate, record, and control temperature:

6. Distance between the thermocouples and the load in an oscillating furnace: _____ inches.

L. Furnace loading information:

1. General description of item distribution in the load (not required when a thermocouple is attached to each item in the load).

(a) Approximate weight or size of batch furnace load:

Pounds (Kilograms) _____ or no. of pieces _____ and size _____

(b) Approximate continuous furnace production rate: _____ pounds/hour

2. General description of the supporting method used.

M. Location of test coupons (when used) in relation to items and attached thermocouples (when used).

N. Furnace survey information:

1. Was this heat treatment used in conjunction with a temperature survey? Yes _____ No _____

Figure 3-2. Information to be Documented on the Heat Treatment Record – Continued

CHAPTER 4 VERIFICATION

4-1 RESPONSIBILITY FOR INSPECTION.

The Contractor is responsible for the performance of all inspection requirements as specified in this document and in appendix A. Unless otherwise specified (see 6-2), the Contractor may use their own or any other facilities suitable for the performance of the inspection requirements specified herein, unless disapproved by the Government. The Government reserves the right to perform any of the inspections set forth in this document where such inspections are deemed necessary to ensure supplies and services conform to prescribed requirements.

4-1.1 PERFORMANCE OF INSPECTION. The performance of the inspections or tests set forth in this document does not relieve the Contractor's responsibility to provide a product that meets all requirements of this document. Test specimens shall be stamped or otherwise marked for identification. Any applied marks shall remain on the test specimens until they are tested, and necessary records are made. The test specimens shall not receive any treatment, working, straightening, or other processing, except for machining that may result in changing the properties to be evaluated by the testing, except as provided in the specific test methods.

4-1.2 EXAMINATION OF MATERIAL AS OFFERED FOR ACCEPTANCE. All applicable examinations and tests required by this document shall be performed on material offered for acceptance, as specified in the applicable appendices.

4-1.3 QUALITY SYSTEM. A quality system that, as a minimum, meets the requirements of ANSI/ASQ ISO 9001, along with the supplemental technical requirements in Appendix B, or an equivalent system, shall be established and maintained.

4-1.3.1 Traceability System. As a minimum, a traceability system to ensure the proper identity of the material shall be maintained.

4-1.4 PRODUCT QUALITY REQUIREMENTS. Every test prescribed by this document, including, but not limited to, first article tests, production lot acceptance tests, and final inspection tests, whether performed by the Contractor or the Government, is a quality assurance tool intended to ensure a consistent manufacturing process and compliance with all requirements of this document.

4-1.5 RESPONSIBILITY FOR COMPLIANCE. All items must meet all requirements of Chapters 3 and 5 of this document and in the applicable appendix. The inspections set forth in this document shall become a part of the Contractor's overall inspection system or quality program. The absence of any inspection requirements in this document, shall not relieve the Contractor of the responsibility of ensuring that all products or supplies submitted to the Government for acceptance comply with all requirements of the contract or purchase order. Sampling for conformance neither authorizes submission of known defective material, either indicated or actual, nor does it commit the Government to acceptance of defective material.

4-1.6 CERTIFICATION OF CONFORMANCE. A certificate of conformance shall be prepared for each lot of material offered for acceptance in accordance with the definition of the applicable appendix. The certificate shall include actual data of specified chemical and mechanical tests, including all test results that failed to meet specified requirements. The build layout information (see 4-3.1.1), qualified DED AM procedure number(s), recorded essential elements, uniformity of heat input data and interpass temperature, referenced digital build files, feedstock and build platform conformance documentation, and a record of the final heat treatment (if applicable) shall also be included. Qualitative results of nondestructive tests and other inspections or tests shall be recorded on the certificate. The certificate shall state that each lot has been sampled, tested, and inspected in accordance with the document requirements. The certificate shall

also state that the manufacturer has maintained adequate manufacturing procedures demonstrated in first article testing as listed and maintained, as specified in 4-3.3 and quality assurance practices, to produce a product that meets the chemical and mechanical property requirements specified throughout the product. The certificate shall state that each lot meets all document requirements and shall be signed by a responsible representative of the Contractor. Where test certificates issued by the manufacturer contain the above data requirements, a separate certificate of conformance is not required. The certificate shall include the revision of the Process Control Plan used and the date of most recent first article approval or recertification.

4-2 CLASSIFICATION OF INSPECTIONS.

The inspection requirements specified herein are classified as follows:

- a. First article inspection (see 4-3)
- b. Conformance inspection (see 4-4)

4-3 FIRST ARTICLE INSPECTION.

First article inspection shall consist of the tests specified in the applicable appendix. Variations from the approved qualification plan, including heat treatment, require approval by NAVSEA. First article material shall be manufactured using qualified AM procedures (see 3-7).

If reheat treatment is used on the first article, heat treatment for procurement may be required to include the same number of heat treatment cycles, with the same definitions (i.e., time and temperature) as that used during first article production based on NAVSEA review of test data.

4-3.1 SAMPLING FOR FIRST ARTICLE INSPECTION. For as-printed material, first article samples shall be taken from the thickest and thinnest member sections to be built in production. For heat-treated AM material, a build representative of the largest AM pre-form thickness to be qualified shall be tested. Sufficient material of all forms shall also be provided for explosion testing if this testing is required in the applicable appendix. Additional first article sampling requirements shall be as specified in the applicable appendix.

4-3.1.1 First Article Build Layouts. The qualification plan shall contain figures that show the first article build in three dimensions in both the pre-machined (i.e., as built) and final dimensions. At a minimum, the figures shall provide the following:

- a. Build platform layout including part(s), specimens, and witness coupons, as applicable.
- b. Build orientation(s) and scaling information (i.e., the build plan).
- c. Extraction locations for destructive tests.
- d. As applicable, markings on the part(s) to include identification scheme.

4-3.2 PROCESS CONTROL PLAN. The manufacturer must demonstrate during first article testing that it has an adequate process to ensure the specified composition and mechanical properties are met throughout the product. The Process Control Plan shall contain information as further described in 4-3.3. This Process Control Plan will document the manufacturing process control procedures/documents used in the production of the first article product. All processing on material offered for acceptance in conformance with this document shall be the same as that performed on material submitted for first article testing as documented in the Process Control Plan with any amendments/revisions allowed as specified herein. This Process Control Plan and all documents referenced or listed in the Process Control Plan shall also be controlled documents. All previous revisions shall be kept on file for audit, and the version of the Process Control Plan used during manufacture of procured products shall be recorded for each delivered lot. The revision record of the Process Control Plan shall also indicate any problems that have been identified by the manufacturer, customers, or NAVSEA with their product that required a Process Control Plan revision, including receipt inspection, fabrication, or in service and how these problems were adequately resolved, and the necessary changes made in the manufacturing procedures to ensure that these problems will not

occur in the future. The Process Control Plan associated with the first article, and a listing of referenced process documents, which become part of the Process Control Plan, shall be submitted to NAVSEA for review for adequacy, prior to the initiation of first article production. The current revision of the Process Control Plan shall also be made available to the procuring activity. NAVSEA may request additional information be added to the submitted Process Control Plan. The Process Control Plan and subsequent revisions shall be available to NAVSEA, or its designated representative, for audit. The manufacturer shall ensure that employees responsible for manufacturing and testing the approved product(s) understand the appropriate procedures (e.g., AM procedure, heat treatment, nondestructive inspection, mechanical property testing) in the plan. Any amendments/revisions to this plan that could negatively affect the properties of the product must be supported by data and submitted to NAVSEA for review for acceptability. The employee training methods shall be available for auditors when requested. The manufacturer shall ensure that an up-to-date copy of the Process Control Plan, including any amendments/revisions, is readily available in the plant for use by auditors when evaluating compliance with procedures approved by first article testing and by employees.

4-3.3 PROCESS CONTROL PLAN CONTENTS. The Process Control Plan shall describe, as a minimum, the following critical processing procedures:

- a. Personnel Training Plan (see 4-3.3.1).
- b. Maintenance Control Plan (see 4-3.3.2).
- c. Digital File Handling Procedure (see 4-3.3.3).
- d. Feedstock Material Handling, Storage, and Control Procedures (see 4-3.3.4).
- e. Build Procedure (see 4-3.3.5).
- f. Heat Treatment Parameters (temperature, time, cooling method, and atmosphere for intermediate (in process) and final heat treatment).
- g. Heat treatment facilities (which facilities were used, etc.).
- h. Any lubricating, de-scaling, cleaning, or pickling operations used during manufacture.
- i. All processes that could negatively impact the final surface and near surface chemical composition of the delivered product.
- j. Change Control Plan that specifies the criteria and plan to verify the acceptability of any change in the critical processing procedures as listed in the Process Control Plan.
- k. Procedures and processes for removing, machining, preparing, and testing of tensile specimens from first articles, prolongations, and/or witness coupons with specific consideration for minimizing hydrogen loss from specimens between removal and testing.
- l. In-Process Monitoring and Control Plan (if applicable, see 4-3.3.6).
- m. Additional requirements as specified in the appendices.

4-3.3.1 Personnel Training Plan. The activity shall maintain a Personnel Training Plan that covers training and qualification of personnel involved in the DED and testing and operations. The plan shall detail training required, initial qualification requirements, and requalification timeframes per S9074-A4-GIB-010/AM-WIRE DED. Personnel shall include, but not be limited to, DED operators, NDT personnel, the various inspectors responsible for work performance, and materials and other engineers in production or support positions. The plan shall include personnel responsible for work performance of the procedure qualification build, part verification builds, and production builds. Written procedures shall be prepared to assign responsibility and provide accountability for performing work and inspections. NDT personnel shall meet the requirements of T9074-AS-GIB-010/271 and shall have additional training specific to NDT of DED parts.

4-3.3.2 Maintenance Control Plan. The Process Control Plan shall contain a Maintenance Control Plan for the DED system and critical associated equipment. At a minimum, the plan shall include maintenance and calibration plans and schedules for all components that control essential machine elements detailed in the AM procedure. At a minimum, the plan shall include the calibration metrics identified by the DED machine manufacturer to declare the equipment fit for use. The plan shall also include the tests or machine checks that will be performed following maintenance, component replacement, or repair to verify the procedures for when the tests or machine checks are failed, and that the equipment is functioning properly. The Maintenance Control Plan shall include the method and schedule for maintenance and calibration of the following, as applicable:

- a. Welding power source.
- b. Robotic arm and tool center point.
- c. Electric motor-controlled positioners.
- d. Torch to work positioning controls (i.e., height tracking).
- e. Build platform motion, alignment, and levelness.
- f. Temperature sensors (e.g., noncontact pyrometer or contact thermocouple).
- g. Machine vision sensors (e.g., camera or lasers).
- h. Acoustic sensors.

4-3.3.3 Digital File Handling Procedure. The Process Control Plan shall contain a Digital File Handling Plan. The Digital File Handling Plan shall provide the sequence and tracking method of the digital files necessary to make the first article and production builds, beginning with the creation of the build files through installation of the build files onto the DED system. The Digital Handling Plan shall detail control measures as necessary to ensure the build files and any dependent files called by the build files (e.g., program files, subroutines, and procedural files) are not compromised. The Digital Handling Plan shall contain a verification plan to demonstrate the build files have not changed during digital transfer. The Digital File Handling Plan shall detail continuous active computer security on all computer systems and associated devices, including storage devices used to transfer files that are associated with any aspect of the build file design and build process. At a minimum, the Digital File Handling Plan shall include the following:

- a. Names of individual part surface mesh files (e.g., stereolithography [STL], additive manufacturing file format [AMF]) used in creation of the procedure qualification, first article and production builds.
- b. Names of build files used to produce the procedure qualification, first article and production builds.
- c. Build file processing software version configuration control.
- d. DED machine software and firmware version configuration control.
- e. Build file transfer verification method.
- f. Relevant Government or commercial digital documents used.

4-3.3.4 Feedstock Material Handling, Storage, and Control Procedure. The Process Control Plan shall contain a DED wire feedstock material handling, storage, and control procedure. At a minimum the procedure shall address the following:

- a. Feedstock handling to prevent damage.
 - (1) Damaged containers shall have their contents examined for excessive moisture and for distorted spools or drums, or entwined winding on spooled or drummed wire. Feedstock

damaged to the extent that it does not meet document requirements shall not be used for production.

- (2) Feedstock shall be stored in a dry area to prevent damage from contamination, moisture, or water.
- b. Identification of feedstock up to point of usage.
 - (1) Each spool or drum coil of feedstock wire shall carry an identifying label.
 - (2) Each piece of feedstock wire shall have distinguishable color code, type designation, or classification number marking.
- c. Feedstock material inspection (see 3-3).

4-3.3.5 Build Procedure. The Process Control Plan shall contain details of build procedures that ensure a consistent, repeatable process. At a minimum, the procedure shall provide the following, as applicable:

- a. In-process grinding and machining.
- b. Treatment of bead deposition starts and stops (i.e., path planning methods to avoid stacking).
- c. Preheat and interpass temperature measurement controls and methods.
- d. Cleaning practices (e.g., needle scaling, wire brushing, grinding) and periodicity (e.g., every bead, every layer, as-needed)
- e. Build platform preparation methods.
- f. Repair procedures, including but not limited to, in-process repairs by grinding or welding, post-build repairs, NDT requirements for defect excavations and completed repairs, and repair criteria.
- g. Controls to ensure uniformity of heat input (see 3-9.4.2)

4-3.3.6 In-Process Monitoring and Control Plan. If applicable, the Process Control Plan shall contain an In-Process Monitoring and Control Plan. When part of a qualified AM procedure, the In-Process Monitoring and Control Plan shall include the step-by-step procedure for conducting continuous in-process monitoring, electronic data collection, recording, and storage to demonstrate adequate process controls and compliance to the qualification limits when used in closed loop feedback. The In-Process Monitoring and Control Plan shall include the monitoring method (such as human monitoring, data acquisition, infrared cameras, sensors, etc.), frequency, sampling rate, and step-by-step procedures used for monitoring and control. When possible, the data shall be traceable to locations within the build volume.

4-3.4 RE-CERTIFICATION OF FIRST ARTICLE APPROVAL. For all materials covered by this document, re-certification of the first article approval of vendor facilities, processes, and manufacturing methods by NAVSEA is required every 5 years. This re-certification will verify that the requirements specified by NAVSEA in the first article approval of the vendor's facilities are being maintained.

Each certified vendor is required to request this re-certification from NAVSEA to maintain its first article certification. The vendor's request shall be submitted to NAVSEA directly with a copy to all procuring activities where applicable. This request shall be submitted at least 6 months prior to the need for re-certification.

At a minimum, the vendor's re-certification submittal shall include the following:

- a. Conformance test results (including alloy, maximum thickness of product as defined in the applicable appendix, mechanical properties, re-test results, and chemical composition) on qualified products produced since qualification or the previous re-certification including production product non-conformances and the associated cause(s) and corrective action(s).
- b. All production related facility changes on facilities used to produce the qualified product over the past 5 years.

- c. All Process Control Plan and DED AM procedure changes over the past 5 years.
- d. The Change Control Plan used to adjudicate changes to the Process Control Plan and required related submittals for approval to NAVSEA by the vendor.

The re-certification process shall include a review of the vendor's submittal requesting re-certification. This may include a request for additional information or data and/or an audit of the facility to review current procedures and equipment, if deemed necessary. Based on the findings of these reviews, additional first article testing may be required for approval of re-certification of the vendor's facility.

Upon successful completion of the re-certification, NAVSEA will issue a re-certification letter. The certification must be current at the delivery date of procured products.

4-4 CONFORMANCE INSPECTION.

Conformance inspection shall consist of the examinations and tests specified in the applicable appendix.

4-4.1 LOT DEFINITIONS.

4-4.1.1 Lot for Chemical Composition. For chemical composition an AM DED lot of material shall be defined as produced from a single lot (heat) of feedstock using the same DED procedure.

4-4.1.2 Lot for Tension Tests. For tension tests, a lot shall be as defined in the applicable appendix.

4-4.1.3 Lot for Impact Tests. For Charpy V-notch and dynamic tear testing, a lot shall be as defined in the applicable appendix.

4-4.1.4 Lot for Examinations and Inspections. For the purposes of visual, dimensional, and nondestructive examination, a lot shall be as defined in the applicable appendix.

4-4.2 SAMPLING.

4-4.2.1 Sampling for Examination. Specimens for examination shall be taken as specified in the applicable appendix.

4-4.2.2 Sampling for Chemical and Spectrographic Analysis. Specimens for chemical analysis shall be taken as specified in the applicable appendix.

4-4.2.3 Sampling for Tension Testing. Specimens for tension testing shall be taken as specified in the applicable appendix.

4-4.2.4 Sampling for Impact Testing. Specimens for impact testing shall be taken as specified in the applicable appendix.

4-4.2.5 Marking of Test Specimens. The test specimens shall be marked to ensure positive identification of the lot being tested.

4-4.3 EXAMINATION. All material shall be examined visually and dimensionally for conformance to the requirements of the applicable appendix. Additional examination shall be as specified in the applicable appendix.

4-4.4 VERIFICATION OF FEEDSTOCK AND BUILD PLATFORM MATERIALS. Material conformance records of feedstocks and build platforms shall be verified to ensure conformance to the applicable document and shall be included as part of the certification package for the AM pre-forms supplied in accordance with this document. Verification shall be accomplished by checking the supplier's material conformance inspection reports against the applicable document requirements and material marking, as applicable, against the material received. Additionally, for material not supplied directly from the manufacturer, the Contractor shall conduct periodic independent testing to establish reasonable confidence in the reliability of material test data in accordance with a written procedure (see 4-3.3.4). If

the Contractor's quality conformance inspection records are not available, the construction activity shall establish document conformance of the material in accordance with a written procedure.

4-5 TEST PROCEDURES.

4-5.1 CHEMICAL AND SPECTROGRAPHIC ANALYSIS. Specimens shall be analyzed in accordance with a standard ASTM method or a method that will ensure equally accurate results for conformance to the chemical composition of the applicable appendix. The method(s) shall be correlated with National Institute of Standards and Technology standard reference materials, when available, to ensure the validity of the test method that is used as a control in chemical analysis or for calibration in instrumental methods of analysis. Additionally, the range over which the chemical analysis test methods can be shown to be accurate for the particular element reported shall be provided. The accuracy and precision of the chemical analysis method(s) used for each element being analyzed shall be provided (see 3-4).

4-5.2 TENSION TEST. Tensile test specimens selected in accordance with the applicable appendix shall be tested in accordance with ASTM A370. Specimens shall be 0.500-inch diameter standard round specimens per ASTM A370, or as specified in the applicable appendix, unless otherwise specified (see 6-2). When dimensions of the product(s) preclude ASTM A370 standard round 0.500-inch (13-mm) specimens, the largest round standard tensile specimens of ASTM A370 that can be obtained from the test material shall be used. If a product is to be aged or otherwise heat-treated to reduce hydrogen, then the tensile test specimen(s) shall be removed from the prolongation or witness coupon, after the hydrogen reduction heat treatment. Tensile specimens or specimen blanks shall not be aged or otherwise heat-treated to reduce hydrogen.

4-5.3 CHARPY V-NOTCH IMPACT TEST. The test specimens shall be tested in accordance with ASTM A370 with coolant temperatures as specified in the applicable appendix. Specimen location and orientation shall be as specified in the applicable appendix, including notch orientation for as-printed material. For heat-treated material, the notch shall be perpendicular to the nearest heat-treated surface.

4-5.4 DYNAMIC TEAR IMPACT TEST. The test specimens shall be tested in accordance with ASTM E604. Coolant temperature shall be minus 40 ± 3 °F (minus 40 ± 2 °C) unless specified otherwise in the applicable appendix. For as-printed material condition specimen location and orientation, including notch orientation, shall be as specified in the applicable appendix. For heat-treated material conditions, the notch shall be perpendicular to the nearest quenched and tempered surface and specimen location and orientation shall be as specified in the applicable appendix.

4-5.5 EXPLOSION TEST. The explosion tests, when required by the applicable appendix, shall be conducted using two explosion crack starter specimens and four explosion bulge specimens fabricated in accordance with Appendix L of T9074-BD-GIB-010/0300, Rev 2. Unless otherwise specified in the applicable appendix, the tests shall be conducted at 0 °F (minus 18 °C). When required by the applicable appendix, the explosion bulge type shall meet the requirements in the applicable appendix.

4-6 REJECTION AND RETESTS.

When a test specimen representing a lot of material fails to meet document requirements, the lot shall be rejected. The Contractor may rework or retest the lot as provided (see 4-6.2 to 4-6.5 and applicable appendices) herein. The Contractor shall identify and separate rejected lots from acceptable lots until the rejected lots are withdrawn by the Contractor or are demonstrated as meeting document requirements. Only one retest of a nonconforming original test is permitted, and the retest specimens shall be taken in the vicinity of the initial location of the failed specimen(s). If any retest specimen fails, the lot shall be rejected with no further testing permitted, except in cases where a lot consists of more than one item (see lot definitions in applicable appendices). When a lot with a rejected test specimen consists of more than one item and the applicable appendix does not provide other instructions, at the option of the Contractor, each item in the rejected lot may be tested for the failed test and each item that fails to meet the requirements of the applicable appendix shall be rejected. All test results, including failures, shall be reported, unless

otherwise approved by NAVSEA in first article approval to accommodate automated data reporting systems. In all cases, all test results, including failures, shall be available for review upon request.

4-6.1 REHEAT TREATMENT. The Contractor shall be permitted to reheat-treat material along with the representative prolongations or witness coupons that fail to meet the tensile or impact requirements of the applicable appendix. Required tests at the same required test location as originally performed on the failed material shall be repeated when the material is re-inspected, except for the chemical analysis. On any additional heat treatment given, including austenitizing/quench and temper/quench, re-tempering/quench or hydrogen soak, all the new mechanical test specimens from the material, prolongation, or witness coupon shall be taken from locations that meet the criteria from as quenched surfaces of the reheat treatment as specified in the applicable appendix.

4-6.2 TENSION RETEST. If the results of an original tensile specimen fails to meet the requirements of the applicable appendix, a retest on two additional specimens, selected from the same approximate location, shall be permitted provided at least one of the following conditions are satisfied:

- a. The measured yield strength is within 1 kilopound per square inch (ksi) (6.9 Megapascals [MPa]) of the applicable requirement, or
- b. The measured elongation is within 2 percent of the applicable requirement, or
- c. The measured reduction in area is within 2 percent of the applicable requirement.

4-6.2.1 Gauge Length Retest. If the percentage of elongation or reduction in area of an individual tensile specimen is less than that prescribed in the applicable appendix, and any part of the fracture is outside the gauge length, or within the gauge length and less than 25 percent of the gauge length from either datum point, it may be replaced by another specimen from the same approximate location.

4-6.3 CHARPY V-NOTCH RETEST. If initial Charpy V-notch test results at a specified temperature do not meet the requirements of the applicable appendix, a retest of two additional sets of specimens (i.e., six specimens) from the same approximate location and at the same temperature shall be permitted on the same material. If the retest specimens do not meet the requirements (average and individual values), the lot represented by the specimens shall be rejected.

4-6.4 DYNAMIC TEAR RETEST. If initial dynamic tear test results at a specified temperature do not meet the requirements of the applicable appendix, a retest of two additional sets of specimens (i.e., four specimens) from the same approximate location and at the same temperature shall be permitted on the same material. If any retest specimen does not meet the requirements, the lot represented by the specimens shall be rejected.

4-6.5 DEFECTIVE SPECIMEN/REPLACEMENT OF TEST SPECIMENS. A test specimen shall be discarded and a replacement specimen selected from the same lot of the material under the following conditions:

- a. When a specimen is incorrectly machined.
- b. When the test procedure is incorrect.
- c. When there is a malfunction of the testing equipment.
- d. When a flaw that is not indicative of an inferior or defective lot of material is revealed during the test. However, internal flaws such as cracks, ruptures, and porosity are not reasons for the selection of a replacement test specimen.

CHAPTER 5 PACKAGING

5-1 PREPARATION FOR PACKAGING AND PACKING.

Preparation for packaging and packing shall be as follows:

- a. Product(s) shall be clean and free of dirt, chips, or any other foreign matter.
- b. Contact preservative shall not be used.
- c. Product(s) shall be segregated as to lot number, composition, finish, and size.

5-2 PACKAGING, PACKING, AND MARKING FOR SHIPMENT.

Unless additional requirements are specified by the purchaser (see 6-2), material shall be prepared for shipment in accordance with commercial practice to ensure delivery of product in full compliance with this document. The level of packaging and marking for shipment shall meet the requirements of carrier rules and regulations applicable to the mode of transportation.

5-3 PACKAGING BY DEPARTMENT OF DEFENSE (DOD) PERSONNEL.

When actual packaging of materiel is to be performed by DoD personnel, these personnel need to contact the responsible packaging activity to ascertain requisite packaging requirements. Packaging requirements are maintained by the Inventory Control Point's packaging activity within the Military Department or Defense Agency, or within the Military Department's System Command. Packaging data retrieval is available from the managing Military Department's or Defense Agency's automated packaging files or by contacting the responsible packaging activity.

CHAPTER 6 NOTES

6-1 INTENDED USE.

This document is intended to provide the general requirements for acquisition of high-strength steel directed energy deposition (DED) additively manufactured pre-forms as described in the applicable appendices.

6-2 ACQUISITION REQUIREMENTS.

Acquisition documents must specify the following, in addition to any additional requirements from the applicable appendix:

- a. Title, number, and date of this document.
- b. Grade required (see 1-2).
- c. If required, the specific issue of individual documents referenced (see 2-2.1 and 2-3).
- d. When first article testing is not required (see 3-1).
- e. When a batch-type furnace working zone temperature survey shall be conducted with a typical, nominal, or simulated furnace load (see 3-11.3).
- f. The specific alternate facility that shall be used (see 4-1).
- g. Dimensions of non-standard tensile test specimens (see 4-5.2).
- h. Any special packaging requirements (see 5-2).

6-3 FIRST ARTICLE.

When a first article inspection is required, the item should be a first article sample. The first article should consist of one unit. The contracting officer should include specific instructions in acquisition documents regarding arrangements for examinations, approval of first article test results, and disposition of first articles. Invitations for bids should provide that the Government reserves the right to waive the requirement for samples for first article inspection to those bidders offering a product that has been previously acquired or tested by the Government, and that bidders offering such products, who wish to rely on production or test, must furnish evidence with the bid that prior Government approval is presently appropriate for the pending contract.

6-3.1 NEW VENDORS. Prior to delivery, manufacturers that have not previously produced products under this document of the material grade specified should demonstrate to the Materials Engineering Division of Naval Sea Systems Command that their facilities produce products conforming to the requirements of this document.

6-3.2 FORWARDING DATA. When a contract does not exist, first article data may be submitted directly to NAVSEA. The first article inspection data should be verified by the Defense Contract Management Agency (DCMA) or by the American Bureau of Shipping (ABS) representative. The report should be forwarded to the Materials Engineering Division of Naval Sea Systems Command via DCMA. Upon review of the report, authorization will be forwarded for preparation of test specimens for the explosion tests as required and instructions shall be furnished for shipment to designated Government testing locations. Specimen preparation and shipment will be under the cognizance of DCMA or ABS representatives, as applicable.

6-3.3 MANUFACTURING AND TESTING. The manufacture of the first article, the laying out of test specimens, and the testing should be witnessed by a representative of the Materials Engineering Division of Naval Sea Systems Command.

APPENDIX A
STEEL GAS METAL ARC ADDITIVELY MANUFACTURED STRUCTURE, LOW-ALLOY,
HIGH YIELD STRENGTH (100S GMAAM)

A-1 SCOPE.

A-1.1 **SCOPE.** This appendix covers grade 100S gas metal arc additively manufactured (GMAAM) steel pre-forms intended as an alternative to HY-80 steel castings for use in critical structural applications where a weldable, notch-tough, high-strength material is required.

A-1.2 **CLASSIFICATION.** Steel GMAAM pre-forms shall be of the following grades, as specified (see A-6.2).

- a. Grade 100S-AP – As-Printed (AP), 80,000 lb/in² (80 ksi) [552 MPa] tensile yield strength, minimum.
- b. Grade 100S-HT – Heat-Treated (HT), 80,000 lb/in² (80 ksi) [552 MPa] tensile yield strength, minimum.

A-2 APPLICABLE DOCUMENTS.

See Chapter 2.

A-3 REQUIREMENTS.

A-3.1 **MATERIAL.** Grade 100S GMAAM steel pre-forms shall be produced using:

- a. MIL-100S-1 classified welding electrodes procured and lot conformance tested in accordance T9074-BC-GIB-010/0200, Appendix B. Lot conformance testing of MIL-100S-1 electrodes used for MIL-100S GMAAM pre-forms shall be performed using the gas metal arc welding (GMAW) process only.
- b. Qualified NAVSEA S9074-A4-GIB-010/AM-WIRE DED AM procedure.
- c. Sacrificial build platform material for 100S-AP/HP components shall be of S-1 carbon steel, groups A, B, or C per table 13-1, Part I.B. of T9074-AD-GIB-010/1688, excluding those that are quenched and tempered. Procurement of the build platform material class or type shall be in accordance with the applicable document specified therein.

A single lot of MIL-100S-1 electrode shall be used for each lot of 100S GMAAM product. Production shall be limited to the same MIL-100S-1 qualified product (i.e., manufacturer and product tradename) used during first article testing.

A-3.2 **CHEMICAL COMPOSITION.** The chemical composition of the lot analysis shall be in accordance with [table A-1](#). Product analysis shall conform to [table A-1](#) as modified by the product analysis tolerances specified in 4.7.5 of T9074-BC-GIB-010/0200. Chemical analysis shall be performed in accordance with AWS A5.28/A5.28M. Carbon equivalent shall be calculated in accordance with paragraph 4.8.3 of T9074-BC-GIB-010/0200.

A-3.3 THICKNESS DEFINITION.

- a. The GMAAM pre-form thickness (AP-T or HT-T) shall be defined as the diameter of the greatest inscribed sphere in the as-printed or heat-treated AM pre-form at the time of printing or heat treating, as applicable.
- b. Where T is used by itself, it shall represent the GMAAM pre-form defined as the diameter of the inscribed spheres (largest or smallest, as prescribed) at any location in the AM pre-form when used for evaluation of mechanical properties, determination of hydrogen annealing times, and local weld repairs.

Table A-1. Chemical Composition (Weight Percent) ^{1/}

Element	Weight Percent (single values are maximums)
	Grades 100S-AP/HT
Carbon	0.07
Manganese	1.25 – 1.8
Phosphorus	0.012
Sulfur	0.008
Silicon	0.20 – 0.55
Nickel	1.40 – 2.10
Chromium	0.30
Molybdenum	0.25 – 0.55
Vanadium	0.05
Titanium	0.10
Zirconium	0.10
Aluminum	0.10
Copper	0.30 ^{2/}
Arsenic	0.025 ^{2/}
Tin	0.03 ^{2/}
Antimony	0.025 ^{2/}
Nitrogen	^{2/, 3/}
Oxygen	^{2/, 3/}
Boron	^{2/, 3/}
Carbon Equivalent	0.23
NOTES:	
^{1/} For definition of lot for analysis, see A-4.4.1.2 and A-4.4.2	
^{2/} Elements shall not be intentionally added.	
^{3/} Nitrogen, Oxygen, and Boron shall be analyzed to the parts per million (ppm) level, reported for information. Boron measurement shall be used for calculating the carbon equivalent.	

A-3.4 TENSILE PROPERTIES. The material shall meet the tensile property requirements as specified in [table A-2](#) after printing or all heat treatments including, when approved by NAVSEA (see A-3.7.c), stress relief. Tensile properties shall meet the requirements in [table A-2](#) at any location in the first article at an equivalent depth below the as-printed or heat-treated surface as the location of the tensile specimens in the prolongation or witness coupon (see A-4.3.2.2).

Table A-2. Tensile Property Requirements

Property	Required Value			
	Grade 100S GMAAM-AP		Grade 100S GMAAM-HT	
T ≤ 6 inches (152 mm) ^{1/}, ^{2/}				
Location	T/2 or 2 inches (51 mm)		T/2 or 2 inches (51 mm)	
Yield strength, 0.2% offset, ksi (MPa)	80 – 99.5 (552 – 686)		80 – 99.5 (552 – 686)	
Elongation in 2 inches, minimum percent	20		20	
Reduction of area, minimum percent	50		50	
6 inches (152 mm) < T ≤ 10 inches (254 mm) ^{1/}				
Location	T/4 or 2 inches (51 mm) ^{2/}	T/2 ^{3/}	T/4 or 2 inches (51 mm) ^{2/}	T/2 ^{3/}
Yield strength, 0.2% offset, ksi (MPa)	80 – 99.5 (552 – 686)	80 – 99.5 (552 – 686)	80 – 99.5 (552 – 686)	78 – 99.5 (538 – 686)
Elongation in 2 inches, minimum percent	20	20	18	15
Reduction of area, minimum percent	50	50	50	50
T > 10 inches (254 mm) ^{1/}				
Location	T/4	T/2 ^{3/}	T/4	T/2 ^{3/}
Yield strength, 0.2% offset, ksi (MPa)	80 – 99.5 (552 – 686)	80 – 99.5 (552 – 686)	80 – 99.5 (552 – 686)	76 – 99.5 (524 – 686)
Elongation in 2 inches, minimum percent	20	20	18	15
Reduction of area, minimum percent	50	50	50	50
NOTES:				
^{1/} Ultimate tensile strength shall be reported for information only.				
^{2/} For T up to and including 4 inches (102 mm), sample location shall be T/2. For T greater than 4 inches, sample location shall be T/4 or 2 inches (51 mm), whichever is greater.				
^{3/} For T greater than 6 inches (152 mm), a second set of specimens shall be taken at T/2, unless otherwise specified (see A-6.2).				

A-3.5 IMPACT PROPERTIES. The material shall meet the impact requirements as specified in [table A-3](#), after printing or all heat treatments, including stress relief when approved by NAVSEA (see A-3.7.c). The impact properties shall meet the requirements of [table A-3](#) at any location in the first article

at a depth below the as-printed or heat-treated surface equivalent to the location of the impact specimens in the prolongation or witness coupons.

Table A-3. Impact Property Requirements

Impact Requirements at T/2 and T/4 Test Locations for Grades 100S-AP and 100S-HT, Unless Otherwise Specified in this Table ^{1/, 2/, 3/}			
	Charpy V-Notch Temp: -100 °F (-73 °C)	Charpy V-Notch Temp: 0 °F (-18 °C)	Dynamic Tear Temp: -40 °F (-40 °C)
T ≤ 4 inches (102 mm), T/2	50 ft-lb (68 J) Avg Min; % Shear Required	70 ft-lb (95 J) Avg Min; % Shear Required	For Info Only ^{4/}
T > 4 inches (102 mm), T/4 or 2 inches (51 mm), whichever is greater			
T < 5/8 inch (16 mm)	50% Avg Min Shear	% Shear for Info Only	Not Required
5/8 inch (16 mm) ≤ T ≤ 6 inches (152 mm)	50% Avg Min Shear	% Shear for Info Only	For Info Only ^{4/}
6 inches (152 mm) < T < 12 inches (305 mm)	40% Avg Min Shear	% Shear for Info Only	For Info Only ^{4/}
T ≥ 12 inches (305 mm)	35% Avg Min Shear	% Shear for Info Only	For Info Only ^{4/}
Impact Requirements for Second Set of Specimens Taken at T/2 for 100S-HT GMAAM ^{1/, 2/, 5/}			
	Charpy V-Notch Temp: -100 °F (-73 °C)	Charpy V-Notch Temp: 0 °F (-18 °C)	Dynamic Tear Temp: -40 °F (-40 °C)
6 inches (152 mm) < T < 10 inches (254 mm), unless otherwise specified (see A-6.2)	50 ft-lb (68 J) Avg Min; % Shear Required	70 ft-lb (95 J) Avg Min; % Shear Required	For Info Only ^{4/}
T ≥ 10 inches (254 mm)	30 ft-lb (41 J) Avg Min; % Shear Not Required	50 ft-lb (68 J) Avg Min; % Shear Not Required	^{4/}
NOTES:			
^{1/} Sampling and location of test specimens shall be as specified in A-4.3.2.2, A-4.3.2.5, and A-4.3.2.6 for first article and A-4.4.3, A-4.4.3.3, and A-4.4.3.4 for conformance inspection.			
^{2/} Average of three specimens. No single Charpy V-notch energy value shall be below the minimum required average by more than 5 ft-lb (7 joules).			
^{3/} The percent shear fracture shall be measured on each specimen.			
^{4/} Data shall be forwarded to the NAVSEA Materials Engineering Group until otherwise advised by NAVSEA.			
^{5/} Unless otherwise specified (see A-6.2), for T greater than 6 inches (152 mm), additional Charpy V-notch impact tests and dynamic tear tests shall be conducted at a depth of T/2.			

A-3.6 ADDITIONAL CONFORMANCE TESTING. When AP-T exceeds 10 inches (254 mm) and when the HT-T exceeds 20 inches (508 mm), additional conformance testing may be required. If a supplier determines that their manufacturing method will lead to the use of a HT-T exceeding 20 inches (508 mm), the supplier shall seek guidance from the procuring agent on whether additional conformance testing will be required, and what that conformance testing will entail.

A-3.7 HEAT TREATMENT. The detailed procedure to produce grade 100S-HT GMAAM pre-forms that meet the mechanical requirements specified herein shall be determined, with the following restrictions:

- a. The grade 100S-HT pre-forms shall be quenched and tempered. Two austenitization and quenching heat treatments are required prior to the tempering heat treatment. The tempering temperature shall be not less than 1125 °F (607 °C). The tempering temperature for at any location on the AM shape shall not exceed 1175 °F (635 °C). After tempering and stress relief heat treatments (see A-3.7.c), all AM pre-forms, including the witness coupon (s) that constitute the furnace load shall be removed from the furnace and rapidly cooled by water quenching at the same time (i.e., the same quench load). The use of more than one quench load for tempering and stress relief heat treatment of a single furnace load of pre-forms is prohibited. Witness coupons shall accompany the AM pre-forms they represent in all thermal treatments and shall be quenched at the same time (i.e., in the same quench load) as the AM pre-forms that they represent. All AM pre-forms shall be arranged such that, as far as possible, they and the witness coupons receive equal and uniform exposure to the quench media. Where it is determined not possible to arrange the witness coupon where the pre-form and the witness coupon receive equivalent exposure, the customer must be advised and agree to the quenching arrangement.
- b. Unless otherwise specified (see A-6.2), the tempering and stress relief heat-treat cycles shall have the following contact thermocouples attached to the AM pre-forms and the witness coupons during the cycles: one contact thermocouple shall be placed on the thickest and thinnest sections of the AM pre-forms in the furnace load, and on the AM pre-forms or witness coupon surface closest to a furnace burner. In addition, one contact thermocouple shall be placed on the witness coupon representing the furnace load. Upon reaching the target tempering and stress relief heat treatment temperature, the temperatures on all AM and witness coupon thermocouples shall be within ± 25 °F (± 14 °C) of the target temperature. In addition, the temperature on the thermocouple attached to the thickest section of the thickest pre-form in the load shall fall within ± 25 °F (± 14 °C) of the thermocouple attached to the thickest witness coupon.
- c. Stress relief of grades 100S-AP and 100S-HT pre-forms is not permitted unless approved by NAVSEA on a case basis.
- d. For all heat treatment options, AM pre-forms shall be positioned and supported in such a manner to prevent shifting or falling from their initial set positions during the heat treatment process. In addition, during tempering and stress relief, AM pre-forms shall be positioned in the furnace so that, in a direct fired furnace, burner flames and hot gases from these flames cannot impinge upon AM pre-forms surfaces, and result in heating the AM pre-forms above the maximum allowable tempering temperature. As a minimum, the AM pre-forms shall be supported in the furnace by a grating/floor structure or similar structure that ensures that the AM pre-forms cannot fall or shift outside of the furnace working zone and be exposed to burner flames or hot gases. The structure supporting the grating/floor in the furnace, such as pylons, sawhorses, and racks, shall be in a permanent/semi-permanent position and shall not deflect flames and hot gases onto AM pre-forms surfaces.
- e. In addition to the requirements of 3-11 for batch-type furnaces, the heat treatment record shall also include digital photographs and sketches providing sufficient accuracy to recreate positions and orientations of the AM pre-form in the furnace at future dates. The sketches shall identify every part in the load uniquely according to a vendor's internal tracking methodology. The photographs in the heat treatment record shall be of the furnace car load immediately prior to

entering and immediately after leaving the furnace for the tempering cycle(s) and stress relief. The sketches in the heat treatment record shall include placement of AM pre-forms, AM pre-form-support structure (i.e., pylons, sawhorses, racks, etc.) on the furnace car, placement of the burners in the furnace, and the distances and orientations of the AM pre-forms and support structure with respect to the burners.

- f. The quench tank facility used for quenching after austenitizing shall be of sufficient capacity and design to provide multi-directional water flow (i.e., from at least three directions, or other equivalent designs based on data and on results of first article testing) to provide for effective quenching of the largest AM pre-forms to be heat-treated. The effectiveness of the quench tank facility in terms of capacity and water flow shall be demonstrated during first article testing where both the largest size (i.e., thickness and complexity) AM pre-forms and the accompanying witness coupons are demonstrated to meet the minimum mechanical property requirements. The maximum quench tank water temperature at the initiation of the quenching operation shall not exceed 80 °F (27 °C). A process shall be put in place to maintain the effectiveness (e.g., flow rate and water capacity) of the quench tank similar to that used during the production and processing of first article test material.

A-3.7.1 Simulated Stress Relief. When a simulated stress relief is specified (see A-6.2), a prolongation or witness coupon as specified in A-4.3.1.2 shall be subjected to the stress relief thermal cycle based on the tempering temperature of the materials (see A-3.2), shall be tested for tensile and impact properties in accordance with A-4.4, and shall meet the requirements specified in A-3.4 and A-3.5. The stress relief thermal cycles (including cooling rates) shall be specified (see A-6.2). Stress relief shall be specified only when necessary to meet machining tolerances, and approved by NAVSEA (see A-3.7.c).

A-3.8 EXPLOSION PERFORMANCE. For explosion crack starter, the crack starter bead shall crack on the first shot without the crack extending through the thickness of the plate, no piece shall be thrown out of explosion crack starter plates, no cracks shall extend to the hold-down area, and the percent reduction in area shall be recorded for information only. No piece shall be thrown out of explosion bulge plates, no through-thickness cracks shall be present on the first two shots, no cracks shall extend into the hold down area, and 10 percent reduction in thickness shall be achieved.

A-3.9 CLEANING. Prior to heat treatment for properties, the AM pre-forms shall have the build platform and any support structure and all potential contaminants removed. Prior to the final inspection and the NDT inspection, all rough spots shall be removed by mechanical means and meet ACI - surface indicator scale (SIS-3) or better. Gouges on flame or arc cut surfaces shall be repaired in accordance with the specified fabrication document (see A-6.2). Gouges shall not exceed 1/8-inch (3-mm) depth and shall not result in the AM pre-form thickness falling below the minimum design dimension of the component.

A-3.10 INTERNAL AND EXTERNAL SOUNDNESS. AM pre-forms shall be of uniform quality and condition as determined by visual examination and magnetic particle and ultrasonic testing. Liquid penetrant testing may be used to supplement or replace magnetic particle inspection where magnetic particle inspection is impractical. Radiographic testing may be used to supplement or replace ultrasonic testing when approved by NAVSEA. Nondestructive inspection shall be performed in accordance with T9074-AS-GIB-010/271. The extent of inspection and the acceptance criteria shall be in accordance with [table A-4](#) and the contract or purchase order (see A-6.2).

Table A-4. Nondestructive Inspection and Acceptance Criteria

Method	Extent of Inspection	Timing of Inspection	Acceptance Criteria
VT	^{1/}	After cooled to ambient	MIL-STD-2035A, class 2, and T9074-AD-GIB-010/1688, Paragraph 7.4
MT	100% of all accessible surfaces	^{2/}	T9074-AD-GIB-010/1688, Paragraph 7.5
PT	100% of all accessible surfaces	After cooled to ambient	T9074-AD-GIB-010/1688, Paragraph 7.7 ^{3/}
UT	Per table 15-1 of T9074-AD-GIB-010/1688 RT coverage minimum	^{4/}	MIL-STD-2035A, class 1, Paragraphs 8.1 and 8.2 for welds
RT	^{5/}	^{5/}	MIL-STD-2035A, class 2, Paragraphs 5.2.1 and 5.2.3 for welds

NOTES:

^{1/} AM builds left in the as-printed surface condition shall receive 100 percent VT.

^{2/} Regarding MT of builds of 100S-AP/HT GMAAM pre-forms: For builds that will be put into service without heat treatment, MT shall be completed no sooner than 160 hours after the build has been completed and cooled to ambient. MT is required of components that have lost preheat prior to returning to fabrication. MT of heat-treated builds may be performed once the component has cooled to ambient following all heat treatments. Heat treatment is as defined in the S9074-A4-GIB-010/AM-WIRE DED.

^{3/} When PT is substituted for MT, the acceptance criteria shall be the same as for MT.

^{4/} For 100S-AP/HT GMAAM pre-forms, UT shall be performed no sooner than 8 hours after the build has cooled to ambient. For other materials, UT shall be performed once the build has cooled to ambient.

^{5/} RT may be used to supplement UT to achieve required coverage when approved by NAVSEA. The submittal to NAVSEA for approval shall include the proposed procedure and shooting sketch. If RT is supplementing UT, the UT scan plan and coverage shall also be provided.

A-3.11 REPAIR OF DEFECTS. Welding may be used to repair defects in accordance with the applicable fabrication document and as specified herein. The applicable fabrication document shall be as specified (see A-6.2). Defects not requiring welding may be ground or chipped out, provided the width of the defective area is at least three times its depth and gradually tapered into the defect and the design thickness is not violated. The locations of all nominal and special weld repairs shall be maintained by the AM material supplier and shall be provided with the AM component, unless otherwise specified (see A-6.2). Repair methods and inspection requirements shall be in accordance with the applicable fabrication document and as specified herein. Specific requirements for weld repairs are provided (see A-3.11.1, A-3.11.2, and A-3.11.3).

A-3.11.1 Prohibited Filler Metals. MIL-120S-1 and MIL-12018-M2 or equivalent strength welding consumables shall not be used for any welding including repair welding and weld build-up. All weld repairs and weld build-up, when approved in accordance with the applicable fabrication document, shall be performed using only MIL-10718-M or MIL-100S-1 electrodes.

A-3.11.2 **Minor Repairs.** Minor repairs in 100S-AP/HT GMAAM pre-forms may be performed using MIL-10718-M or MIL-100S-1 type electrodes provided that the approvals required by the application fabrication document are obtained. Minor repairs are repairs of surface defects for which the excavations do not exceed the following limits:

- a. The maximum depth does not exceed ½ inch or 20 percent of the AM pre-form thickness, whichever is less.
- b. Individual repair areas do not involve more than 2 percent of the AM pre-form surface.
- c. The total repair area does not exceed 10 percent of the AM pre-form surface.

HY-80 steel preheat/interpass temperature and heat input limitations per the fabrication document specified in A-6.2 shall be required. MIL-10718-M or MIL-100S-1 type electrodes shall be purchased to T9074-BC-GIB-010/0200. Specific welding procedures with the above guidelines shall be submitted to the purchaser for approval. Furthermore, the type of welding filler material used to accomplish minor weld repairs shall be identified in the welding procedures submitted to the purchaser for approval.

A-3.11.3 **Nominal and Special Repairs.** Nominal and special repairs of 100S-AP/HT GMAAM are required for defects that exceed the limitations of minor repairs as described in A-3.11.1 and shall require the relevant approvals for nominal and special repairs in castings from the applicable fabrication document. Nominal and special repairs in 100S-HT GMAAM pre-forms may be performed using MIL-10718-M or MIL-100S-1 type electrodes that are purchased to T9074-BC-GIB-010/0200, unless otherwise approved. Nominal and special repairs in 100S-AP GMAAM pre-forms may be performed using only MIL-10718-M electrodes, except that MIL-100S-1 type electrodes may be used when the pre-form thickness at the repair is greater than or equal to 1 inch (25 mm). Such repairs are limited to the following local pre-form thickness (not defect depth) and heat input combinations shown in [table A-5](#). Repairs where local thickness is less than ½ inch shall require NAVSEA approval.

Table A-5. Local AM Shape Weld Repair and Heat Input Combination Limits

Local AM Pre-Form Thickness, inch (mm)	Maximum Heat Input (kJ/inch)
½ (14) to < ⅝ (16)	35
⅝ (16) to < ¾ (19)	45
≥ ¾ (19)	55

A-3.12 **DIMENSIONS AND TOLERANCES.** As-printed or heat-treated AM pre-forms shall be provided with reference points, dimensions, and tolerances as specified (see A-6.2) and shown on the applicable drawing(s).

A-3.13 **MARKINGS.** The AM pre-forms shall be identified with the Contractor’s name or trademark and a serial number, which will positively identify the AM shape to the part number and feedstock lot from which they were built and the lot with which they were heat-treated, if applicable. The locations of the markings shall be as shown on the drawings (see A-6.2).

A-3.14 **HARDNESS.** The Brinell hardness (HB) at all AM pre-form locations as shown on the drawings shall be reported for information.

A-3.15 **MINIMUM PREHEAT TEMPERATURE.** Build platform and build surface minimum preheat temperatures shall be 150 °F when either member widths or thicknesses are less than or equal to 2¾ inches. When either member widths or thicknesses are greater than 2¾ inches, the minimum build platform or build

surface temperature shall be 200 °F. Alternative minimum preheat temperatures may be used with NAVSEA approval.

A-3.16 MINIMUM AND MAXIMUM INTERPASS TEMPERATURE. Minimum interpass temperature shall be no less than the required minimum preheat temperature. For Grade 100S-AP, the maximum allowable interpass temperature shall be 500 °F. Production interpass temperature ranges shall be established by each AM activity's procedure qualification testing, within the limits specified herein.

A-4 VERIFICATION.

A-4.1 RESPONSIBILITY FOR INSPECTION. See 4-1.

A-4.2 CLASSIFICATION OF INSPECTION. The inspections specified herein are classified as follows:

- a. First article inspection (see A-4.3).
- b. Conformance inspection (see A-4.4).

A-4.3 FIRST ARTICLE INSPECTION. First article inspection shall consist of the samples, examinations, and tests specified in A-4.3.1 through A-4.3.2 and in [table A-6](#) (see A-6.3, 4-3, and T9074-BD-GIB-010/0300, Appendix L).

Table A-6. First Article and Conformance Inspection Requirements

Examination and Tests	Requirements	Test Method	First Article	Conformance
Chemical Analysis	A-3.2	4-5.1 and A-4.4.2	X	X
Tensile Properties	A-3.4	4-5.2	X	X
Explosion	A-3.8	4-5.5	X	-
Hardness	A-3.14	A-4.3.2.9 and A-4.4.4.1	X	X
Impact Properties				
Charpy V-Notch	A-3.5	4-5.3	X	X
Dynamic Tear	A-3.5	4-5.4	X	X
Transition Test Curve	N/A	A-4.3.2.7	X	-
Examination				
Surface Quality	A-3.9 and A-3.10	A-4.4.4 and table A-4	X	X
Dimensional	A-3.12	-	X	X
Internal Soundness	A-3.10	A-4.3.2.1 and A-4.4.4	X	X

A-4.3.1 First Article Samples. First article samples shall be as specified in A-4.3.1.1 through A-4.3.1.3.

A-4.3.1.1 GMAAM Pre-Forms. The first article sample shall be a GMAAM pre-form representative of the largest (i.e., largest section thickness) and thinnest size (i.e., the smallest section thickness) to be built of grade 100S-AP or 100S-HT GMAAM material at the facility and shall be approved by NAVSEA. One 100S-AP or 100S-HT GMAAM shape representative of largest and thinnest size, and sufficient complexity to demonstrate the capability to provide AM pre-forms with acceptable chemical composition and mechanical properties throughout the volume of the pre-form, shall be printed for first article inspection. [Figure A-1](#) provides guidance on a suitable thick/complex first article AM pre-form to demonstrate capability of the qualifying AM material supplier in the weight category of either at or below, or above 15,000 pounds (6810 kg) as illustrated in the drawings on [figure A-1](#). When approved by NAVSEA, the

qualifying AM material supplier may use alternate first article pre-form(s) to those illustrated on [figure A-1](#) to demonstrate capability. Unless otherwise specified (see A-6.2), 100S-AP and 100S-HT GMAAM grades shall be tested separately.

A-4.3.1.1.1 Capability and Feasibility of AM Design. Prior to submission of a quote of a new design by a supplier, the purchaser shall integrate with the qualified AM material supplier and ensure design manufacturability with the expectation of achieving acceptable properties and soundness throughout the article. Where agreement on additive manufacturability cannot be reached to support production, the purchaser shall notify NAVSEA.

A-4.3.1.2 Prolongation or Witness Coupons. All AM pre-forms shall require representative prolongation(s) or witness coupon(s) according to the requirements herein. When specified (see A-6.2), a representative sample, in the form of a prolongation, or witness coupons, shall be forwarded with the material to verify properties, after the proposed stress relief, as specified in the applicable fabrication document.

A-4.3.1.2.1 For 100S-HT Pre-Forms. Unless otherwise specified (see A-6.2), representative prolongation(s) or witness coupon (s) for 100S-HT GMAAM or stress relieved (see A-3.7.a) material shall be integrally built with the AM pre-form(s) it represents, or attached in a manner approved by the purchaser to the AM pre-form(s) being represented by the prolongation or witness coupon. The AM pre-form and prolongation or witness coupon representing the AM pre-form shall be heat-treated (including quenching) together through all thermal cycles. The prolongation or witness coupon shall be located such that the prolongation or witness coupon soak time and temperature during all heat treatments are the same as the AM pre-form, and that during quenching operations the prolongation or witness coupon receives a uniform exposure to the quench medium that is equivalent to that received by the thickest part of the AM pre-form. When the witness coupon remains attached to the AM pre-form, it shall not obstruct quenchant flow through all thermal cycles.

A-4.3.1.2.2 Prolongation or Witness Coupon Size. The size of the prolongation or witness coupon shall be equal to the diameter (HT-T) of the largest sphere that can be inscribed in any cross-section of the as-heat-treated AM pre-form. The minimum dimensions of a witness coupon are specified in [table A-7](#), except that for 100S-AP AM pre-forms, witness coupons shall be per A-4.3.1.2.4.

Table A-7. Dimensions of Witness Coupons

Prolongations/ Witness Coupon Sizes	
T, inches (mm)	Witness Coupon Dimension, inches (mm) ^{1/}
Under 1 (25)	1 by 7 by 7 (25 by 178 by 178)
1 to 2, exclusive (25 to 51)	T by 4.5T by 4.5T
2 to 4, exclusive (51 to 102)	T by 3T by 3T
4 and over (102)	T by T by 6(T) ^{1/2}
NOTES: ^{1/} Dimensions specified are minimums. The dimensions, particularly the length or longest dimension on T of 4 inches and over, may be increased in order to secure a practical prolongation or witness coupon for heat treating and cutting tests and for possible retest, if necessary. Extra witness coupon(s) may be built for possible retest.	

A-4.3.1.2.3 Prolongation or Witness Coupon Heat Treatment. Prolongations/witness coupons shall accompany the AM pre-form through all the heat treatment cycles, including quenching, and shall receive the same thermal treatment as the parent AM pre-form. For austenitizing and tempering, the prolongation or witness coupon shall be located in the furnace so that air circulation around it is not impeded by the AM pre-form and to ensure that the prolongation or witness coupon temperature and soak time are the same as that of the AM pre-form. For quenching, the witness coupon shall be located such that, as far as possible, the prolongation or witness coupon receives uniform exposure to the quench media equivalent to that received by the AM pre-form.

The verification of inspection record shall validate the AM pre-forms was loaded in accordance with the sketches and/or photographs in the heat treatment record (see A-3.7.e). The verification of inspection record shall also validate the sketch(es) and photograph(s) are consistent with all support structure and AM pre-forms positions during the tempering heat treatment.

A-4.3.1.2.4 Prolongation or Witness Coupon As-Printed Builds. For as-printed AM pre-forms, the size of the prolongations shall be equal to the diameter (AP-T) of the largest and smallest sphere that can be inscribed in any cross-section. The minimum dimensions of a witness coupon are specified in [table A-7](#). Alternatively, in lieu of integrated prolongations, as-printed witness coupons in the shapes of walls or blocks representing the largest and smallest inscribed sphere member thicknesses may be printed alongside the production build, with NAVSEA approval. The AP-T in the witness coupons shall represent the wall/block width dimension. The height and length of the witness coupons shall be long enough to contain all destructive test samples. The largest (AP-T[L]) witness coupon shall be printed at the minimum preheat temperature and lowest aim heat input used in production of the AM pre-form. The smallest (AP-T[S]) witness coupon shall be printed at the maximum interpass temperature and highest aim heat input used in production of the AM pre-form. The AP-T(L) and AP-T(S) witness coupon build parameters should not be construed as the same as the limits defined in the qualified AM procedure, of which these may be a subset.

A-4.3.1.3 Explosion Test Specimens. A minimum of 12 panels with final dimensions 2 by 16 by 55 inches (51 by 406 by 1397 mm) shall be built to evaluate the explosion properties. Over build shall be minimized to achieve near net final thickness of 2 inches (51 mm). Panels shall be machined to final dimensions after printing. Panels shall have a surface finish of 125 Ra or better. For 100S-AP GMAAM explosion test specimens, the highest qualified heat input and maximum interpass temperature shall be used to print the panels.

A-4.3.2 First Article Examinations and Tests. First article inspection shall consist of the examination and tests of A-4.3.2.1 through A-4.3.2.9.

A-4.3.2.1 Examination. The AM pre-forms shall be inspected to ensure soundness and freedom from defects by the same method specified for the production builds (see A-3.10). Test articles may require a surface finish of 125 Ra or better to achieve satisfactory inspections.

A-4.3.2.2 Test Specimen Location. Test specimens for measuring tensile and impact properties for each of the following thicknesses shall be taken from each AM pre-form and each prolongation or witness coupon for first article inspection. For T up to and including 4 inches, test specimens shall be taken such that one surface of the specimen is at a minimum depth of T/2 from all 100S-HT GMAAM heat-treated or 100S-AP GMAAM machined surfaces. For T greater than 4 inches (102 mm) and less than or equal to the maximum thickness approved in first article testing, test specimens shall be taken at a minimum depth of T/4 or 2 inches (51 mm), whichever is greater, from all 100S-HT GMAAM heat-treated or 100S-AP GMAAM machined surfaces. [Figure A-2](#) is provided for test specimen location guidance.

A-4.3.2.2.1 Test Specimen Location in Sections Greater than 6 Inches. Unless otherwise specified (see A-6.2), for all AM pre-forms of T greater than 6 inches (152 mm), a second set of test specimens shall

also be taken such that one surface of the specimen is at a minimum depth of T/2 from all other as-printed or heat-treated surfaces, and, as a minimum, shall exhibit test values no lower than those specified.

A-4.3.2.3 Chemical Analysis. The manufacturer shall demonstrate that the AM process can provide AM pre-forms that meet the chemical composition requirements throughout the product and that AM pre-forms are free from surface contamination by carbon, sulfur, and, when specified (see A-6.2), other detrimental elements. Chemical analyses shall be performed on each tensile specimen or adjacent material from each of the locations specified in A-4.3.2.2. Specimens shall meet the requirements specified in A-3.2 and the conditions in A-4.5.1. Chemical analysis for near-surface carbon, sulfur, and other harmful contamination (see A-6.2) shall be performed after final heat treatment on a protruding test button on the surface of the prolongation, or witness coupon representing the thickest section of the AM pre-form. The button shall be large enough to provide sufficient material to accomplish all required tests. The button will be removed after the last heat treat cycle, if applicable, and the analysis made on the removed button at a depth of 0.015, 0.03, 0.05, 0.10, and 0.20 inch (0.4, 0.8, 1.3, 2.5, and 5 mm) beneath the pre-form surface. The analysis for all elements (i.e., carbon, sulfur, and other specified harmful contaminants) shall meet the requirements specified in A-3.2. Analysis shall be performed using spectrographic methods on the surface, or by combustion analysis of drillings or millings taken from the surface, at the specified depth ± 0.010 inch (± 0.3 mm). In addition to testing the button from the prolongation or witness coupon, chemical analyses for carbon, sulfur, and other specified harmful contamination shall be performed on sample material, drillings, or filings removed from the surface of the first article AM pre-form. Surface samples shall be taken from the prototype AM pre-form at depths and locations approved by NAVSEA that represent the thickest and thinnest sections of the AM pre-form. Additionally, NAVSEA will evaluate possible sources of harmful contamination (see A-6.2) in the manufacturer's AM process and determine the number of test locations to be included in first article testing. Based on results of these tests, NAVSEA will determine if sampling for surface chemical composition is required on production AM pre-forms.

A-4.3.2.4 Tensile Test. One tensile test specimen shall be taken at each location specified in A-4.3.2.2. Specimens shall meet the requirements specified in A-3.4.

A-4.3.2.5 Charpy V-Notch Test. A set of three Charpy V-notch impact specimens from each of the locations specified in A-4.3.2.2 shall be tested at 0 °F (minus 18 °C), and minus 100 °F (minus 73 °C). The specimens shall meet the requirements specified in A-3.5.

A-4.3.2.6 Dynamic Tear Test. A set of two dynamic tear test specimens from each of the locations specified in A-4.3.2.2 shall be tested at -40 °F (minus 40 °C). Test results shall be recorded and shall be provided for information (see [table A-3](#)).

A-4.3.2.7 Transition Test Curve. Charpy V-notch and dynamic tear transition curves shall be developed from impact specimens taken from the thickest section of the first article AM pre-form and from the witness coupon or witness coupon per A-4.3.2.2 and tested at minus 100 °F (minus 73 °C), minus 80 °F (minus 62 °C), minus 40 °F (minus 40 °C), 0 °F (minus 18 °C), and 30 °F (minus 1 °C). A minimum of three Charpy V-notch and two dynamic tear specimens shall be tested at each temperature.

A-4.3.2.8 Explosion Test. Explosion testing is required as part of first article testing and is not required for conformance testing. The explosion test specimens specified in A-4.3.1.3 shall meet the requirements specified herein when tested in accordance with 4-5.5. Two explosion crack starter tests are required for first article testing. Both specimens shall conform to the crack starter configuration requirements on figure L-8 of T9074-BD-GIB-010/0300, Appendix L, with the assembly weld made parallel to the build direction. Explosion crack starter tests shall meet the requirements in table L-1 of T9074-BD-GIB-010/0300. Explosion bulge type shall be in accordance with T9074-BD-GIB-010/0300, Appendix L. The assembly weld shall be made perpendicular to the build direction, and explosion bulge tests shall continue until both a minimum of 4 shots and a minimum of 10 percent reduction in thickness is obtained on one or both sides. For 100S-AP testing, HY-100 explosive charge weight selection (see T9074-BD-GIB-010/0300 Rev 2,

paragraph L.9.3.4) shall be used when first article inspection material yield strengths are greater than or equal to 100 ksi [690 MPa]. HY-80 explosive charge weight selection shall be used for 100S-HT testing.

A-4.3.2.9 Hardness Test. Each first article AM shape pre-form and prolongation witness coupon shall be hardness tested. Hardness tests shall be performed on each sample used for the performance of surface chemical analyses. The number of tests and the location of the tests shall be approved by NAVSEA and shall meet the requirements of A-3.14.

A-4.3.2.10 First Article Inspection Report. See 3-1.

A-4.4 CONFORMANCE INSPECTION. Conformance inspection (i.e., inspections of production lots) shall consist of the examination and tests of A-4.4.2 through A-4.4.4.1 and [table A-6](#). A prolongation or witness coupon (s) (see A-4.3.1.2) shall accompany the lot through all heat treatment cycles and shall receive the same thermal treatment as the parent AM pre-form(s). For 100S-AP/HT GMAAM material grades, two sizes of prolongations/witness coupons shall be tested and heat-treated (as applicable) with each lot. One prolongation or witness coupons shall represent the maximum T of the largest AM shape in a lot, and one shall represent the maximum T of the smallest AM pre-form in a lot. The terms “large” and “small” AM pre-form are defined by the respective T of each. Where AM pre-forms representing a lot are identical with regard to minimum or maximum T, one prolongation or witness coupons will suffice. Witness coupons for 100S-AP GMAAM material shall be per A-4.3.1.2.4. For AM pre-forms less than 6 inches thick, an integrally built prolongation or witness coupons is not required, unless otherwise specified (see A-6.2), and a separately built witness coupons may be used.

A-4.4.1 Lot Definitions.

A-4.4.1.1 Lot for Tensile and Impact Tests. The lot size for tensile and impact tests shall be as follows:

- a. 100S-AP pre-forms with a finished weight of less than 1,000 pounds (454 kg): All pre-forms produced from the same lot of feedstock and printed on the same build plate shall constitute a lot.
- b. 100S-AP pre-forms with a finished weight of 1,000 pounds (454 kg) or more: Each pre-form shall constitute a lot.
- c. 100S-HT pre-forms with an as-heat-treated weight of less than 1,000 pounds (454 kg): All pre-forms produced from the same lot of feedstock, printed on the same build plate, and heat-treated in the same furnace charges shall constitute a lot.
- d. 100S-HT pre-forms with as as-heat-treated weight of 1,000 pounds (454 kg) or more: Each pre-form shall constitute a lot.

A-4.4.1.2 Lot for Examination and Inspection. Each AM pre-form shall constitute a lot.

A-4.4.1.3 Lot for Chemical Composition. Lot for chemical composition shall be as defined in 4-4.1.1.

A-4.4.2 Sampling for Chemical Analysis. Samples for chemical analysis shall be taken as follows. Test samples shall be taken from one of the broken tensile specimens or adjacent material from each prolongation or witness coupon for product analysis. A second test sampling for carbon, sulfur, and other specified harmful contaminants shall be taken from the protruding button on the surface of each prolongation or witness coupon, when required based on first article testing (see A-4.3.2.3). These analyses shall meet the specified limits in A-3.2.

A-4.4.3 Sampling for Mechanical Tests. Prolongations/witness coupons in accordance with A-4.3.1.2 shall be provided for mechanical tests. Test specimen location shall be in accordance with A-4.3.2.2. Additionally, the test specimens shall be grouped together around the mid-length of the prolongation/witness coupon with the tensile and dynamic tear test specimens taken nearest the mid-length.

A-4.4.3.1 Sampling for Mechanical Tests Following Simulated Stress Relief. When specified (see A-6.2), sample material from a prolongation or witness coupon shall be subjected to simulated stress relief operations after quenching and tempering heat treatment or printing, but prior to testing for conformance

to the mechanical property requirements of A-3.4 and A-3.5. The sample material shall not be removed from the prolongation or witness coupon prior to quenching and tempering. The total time at temperature and cooling rate for the simulated stress relief operation shall be as specified (see A-6.2). The cooling rate and the maximum and minimum time at temperature used on the sample material shall be incorporated in the test certification, if applicable, along with the destructive test results.

A-4.4.3.2 Sampling of Tensile Test. One specimen shall be taken from each of the prolongation or witness coupons representing the lot at the locations specified in A-4.3.2.2.

A-4.4.3.3 Sampling for Charpy V-Notch Tests. Three Charpy V-notch test samples shall be taken for each test temperature from each of the prolongation or witness coupons representing the lot at the locations specified in A-4.3.2.2.

A-4.4.3.4 Sampling for Dynamic Tear Tests. Two samples shall be taken from each of the prolongation or witness coupons representing the lot at the locations specified in A-4.3.2.2.

A-4.4.4 Nondestructive Testing. Each AM shape shall be examined for conformance to the requirements of A-3.10.

A-4.4.4.1 Hardness Testing. Each AM pre-form shall be hardness tested in either the final as-printed or heat-treated condition by an approved and qualified method at locations representative of the maximum and minimum thickness (see A-3.14).

A-4.5 TEST PROCEDURES. See [table A-7](#) and 4-5.

A-4.5.1 Chemical Analysis. If any analysis fails to conform to A-3.2, and product analyses are determined, the product analyses shall be used to determine acceptance or rejection.

A-5 PACKAGING.

See Chapter 5

A-6 NOTES.

A-6.1 INTENDED USE. Grade 100S-AP and grade 100S-HT alloy steel GMAAM pre-forms are intended for critical structural applications where a weldable, notch-tough, high-strength material is required. GMAAM 100S-type pre-forms are primarily intended to serve as alternative to HY-80 castings and not a substitution for plate or wrought grade HY-80 or any HY-100 alloy steel product forms. Grade 100S-AP is higher strength than grade 100S-HT GMAAM and is likely to have yield strength level residual stresses similar to weldments with unknown distribution throughout the AM shape. Users are cautioned to consider the impact yield level residual stress may have on their designs and component distortion when selecting grade 100S-AP GMAAM steel pre-forms. References to the Contractor in this application are meant to apply to a specific steel additively manufactured pre-form producer. The use of grade 100S-AP and 100S-HT GMAAM steel in fabricated structures or equipment entails much more than a material document, and caution is advised in the areas of welding, fabrication, and nondestructive testing. Applicable fabrication documents should be required for any construction with these materials.

A-6.2 ACQUISITION REQUIREMENTS. Acquisition documents must specify the following:

- a. Title, number, and date of this document.
- b. Grade required (see A-1.2).
- c. MIL-100S-1 electrode feedstock ordering requirements (see T9074-BC-GIB-010/0200, B.6.2).
- d. If locations on the 100S-HT GMAAM shape other than those specified require contact thermocouples (see A-3.7.b).
- e. When a simulated stress relief sample is required, the number of thermal cycles, the heating and cooling rates, and time at temperature (see A-3.7.1).

- f. When printing of overbuild material by the AM material supplier may be allowed to remain for removal by subsequent machining operations (see A-3.9).
- g. Applicable fabrication document required (see A-3.9 and A-3.11).
- h. The degree of inspection and the acceptability requirements (see A-3.10).
- i. When a record of weld repair locations is not required (see A-3.11).
- j. As-printed or heat-treated AM pre-form dimensions and tolerances (see A-3.12).
- k. Locations of markings shown on drawings (see A-3.13).
- l. When grades 100S-AP and 100S-HT GMAAM pre-forms are to be first article tested together (see A-4.3.1.1).
- m. When prolongations/witness coupons for AM pre-forms 6 inches (152 mm) and greater in thickness are not required to be integrally built or attached in a manner approved by the purchaser (see A-4.3.1.2).
- n. When a representative sample is to be forwarded to verify properties after stress relief (see A-4.3.1.2).
- o. When specimens shall not be taken at T/2 for thick sections (see A-4.3.2.2.1 and [table A-2](#)).
- p. When specimens from T/2, taken from AM pre-forms $T > 6$ inches and less than or equal to maximum thickness qualified by first article inspection approval, shall have minimum tensile and impact toughness requirements other than specified (see A-4.3.2.2.1).
- q. Elements other than carbon and sulfur that are considered harmful contaminants and require surface chemical analysis (see A-4.3.2.3).
- r. Whether an integrally built prolongation or witness coupons is required for pre-forms less than 6 inches thick (see A-4.4).
- s. When sample material is to be subjected to simulated stress relief (see A-4.4.3.1).
- t. Total time at temperature and cooling rate for simulated stress relief (see A-4.4.3.1).
- u. Location of the raised Brinell test pads on the AM pre-form (see A-4.4.4.1).

A-6.3 FIRST ARTICLE. See 6-3.

A-6.3.1 Receipt Inspection. The AM pre-forms will be subject to receipt inspection by the contracting activity to verify conformance to all requirements specified herein. AM pre-forms not conforming to the requirements specified herein may be rejected by the contracting activity. The Contractor may verify the results of the contracting activity's receipt inspection. It is the responsibility of the contracting activity to determine the acceptability of the AM pre-form for the intended application.

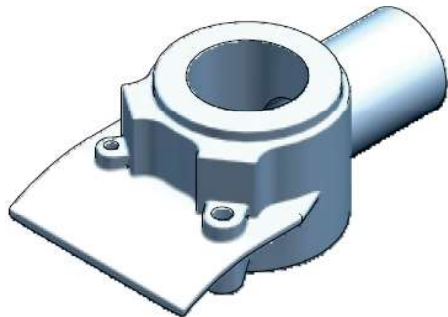

ISOMETRIC A-A

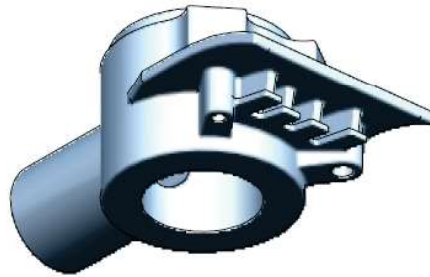

ISOMETRIC B-B

	MINIMUM DIMENSION	MAXIMUM DIMENSION
A	$\varnothing 2T$	$\varnothing 5T$
B	$3.50T$	$5T$
C	$4T$	$6.34T$
D	$2T$	$3.50T$
E	$\varnothing 1.88T$	$\varnothing 2.75T$
F	$2.75T$	$3.75T$
G	$1.25T$	$1.75T$
H	T	$1.75T$
J	$1.38T$	$1.63T$
K	$R 3.77T$	$R 6.20T$
M	$.19T$	$.25T$
N	$.40T$	$.50T$
P	$.28T$	$.23T$
R	$.62T$	$1.13T$
U	$.31T$	$.56T$
V	$.25T$	$.50T$

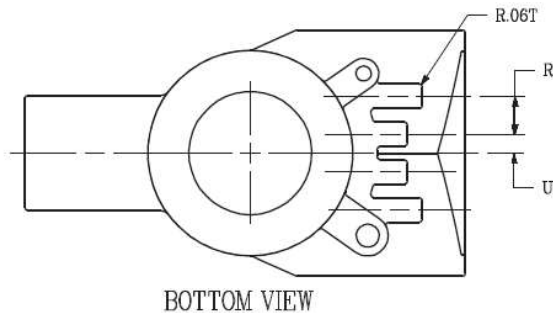
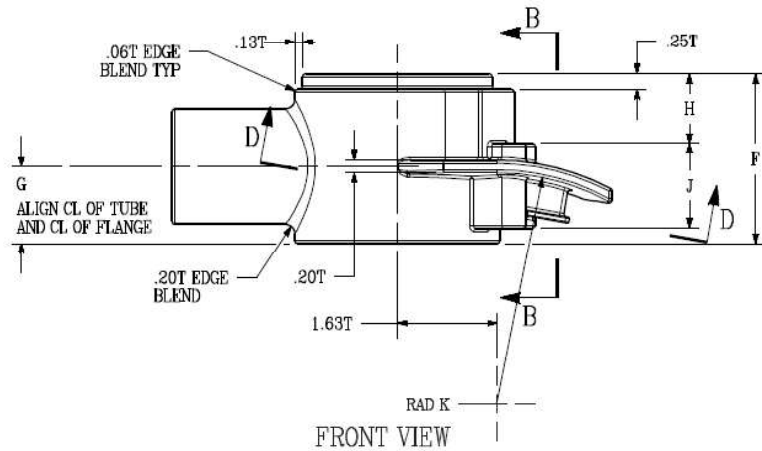
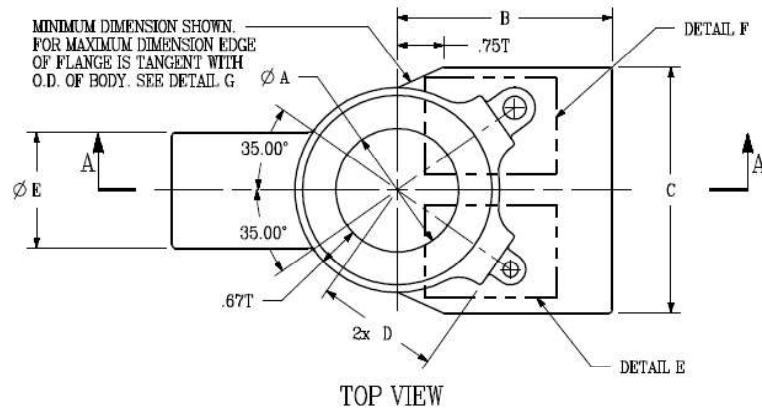

This figure provides guidance on a suitably thick and complex pre-form for qualification to this document. Minimum and maximum dimensioning of this drawing is provided such that a supplier can select dimensioning appropriate for the capacity of their facility. It is intended that a supplier will select a pre-form that will demonstrate their maximum capabilities.

Figure A-1. Sample First Article GMAAM Shape

FIGURE 1

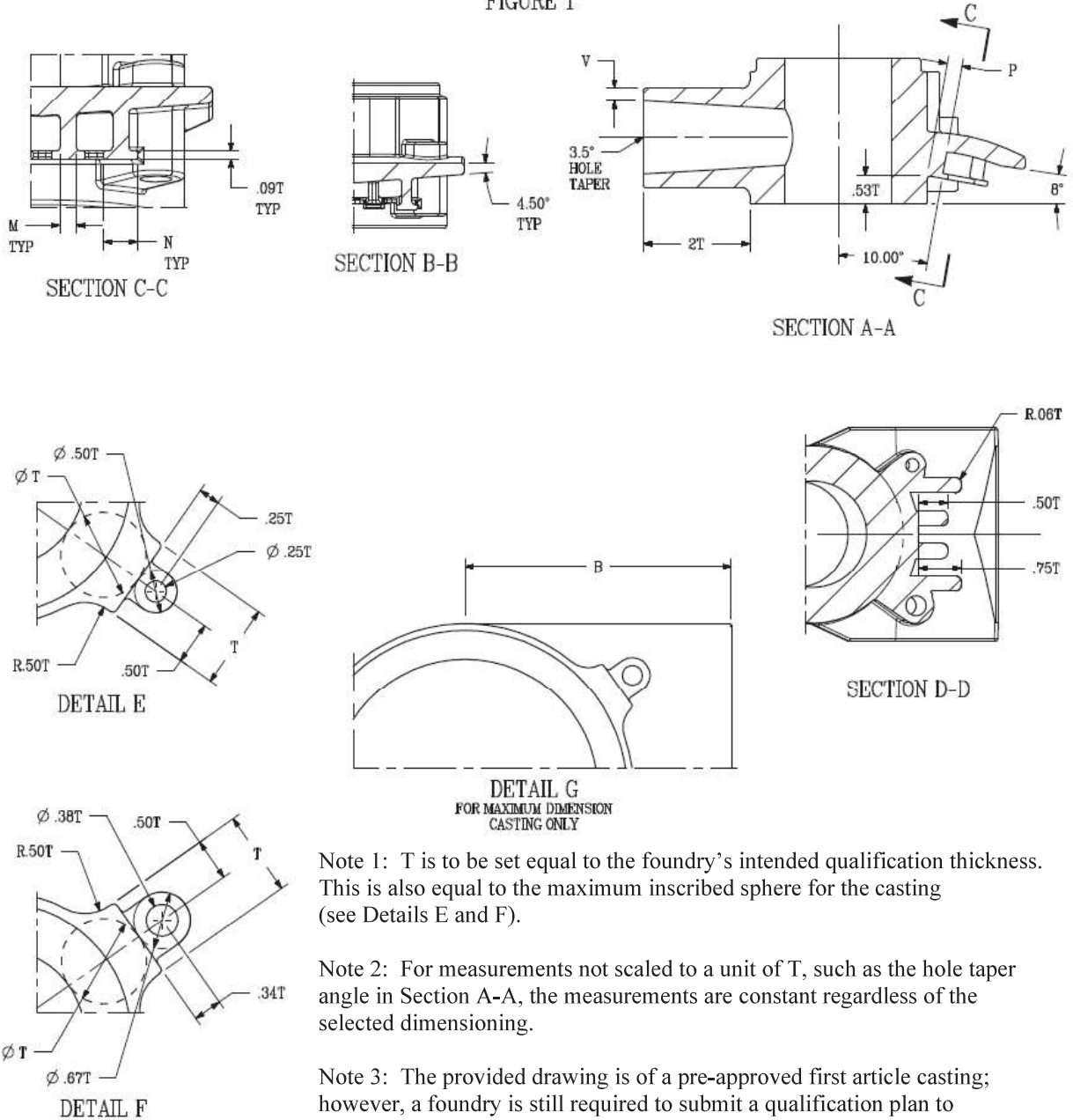

Note 1: T is to be set equal to the foundry's intended qualification thickness. This is also equal to the maximum inscribed sphere for the casting (see Details E and F).

Note 2: For measurements not scaled to a unit of T, such as the hole taper angle in Section A-A, the measurements are constant regardless of the selected dimensioning.

Note 3: The provided drawing is of a pre-approved first article casting; however, a foundry is still required to submit a qualification plan to NAVSEA for approval and a Process Control Plan for NAVSEA review for adequacy as specified in 3-2 and 4-3.2.

Note 4: The foundry may use an alternate first article casting with NAVSEA approval.

Note 5: At T equal to 13 inches, the minimum and maximum dimensioning result in a finished machined weight of 14,445 lbs and 38,295 lbs, respectively.

Figure A-1. Sample First Article GMAAM Shape – Continued

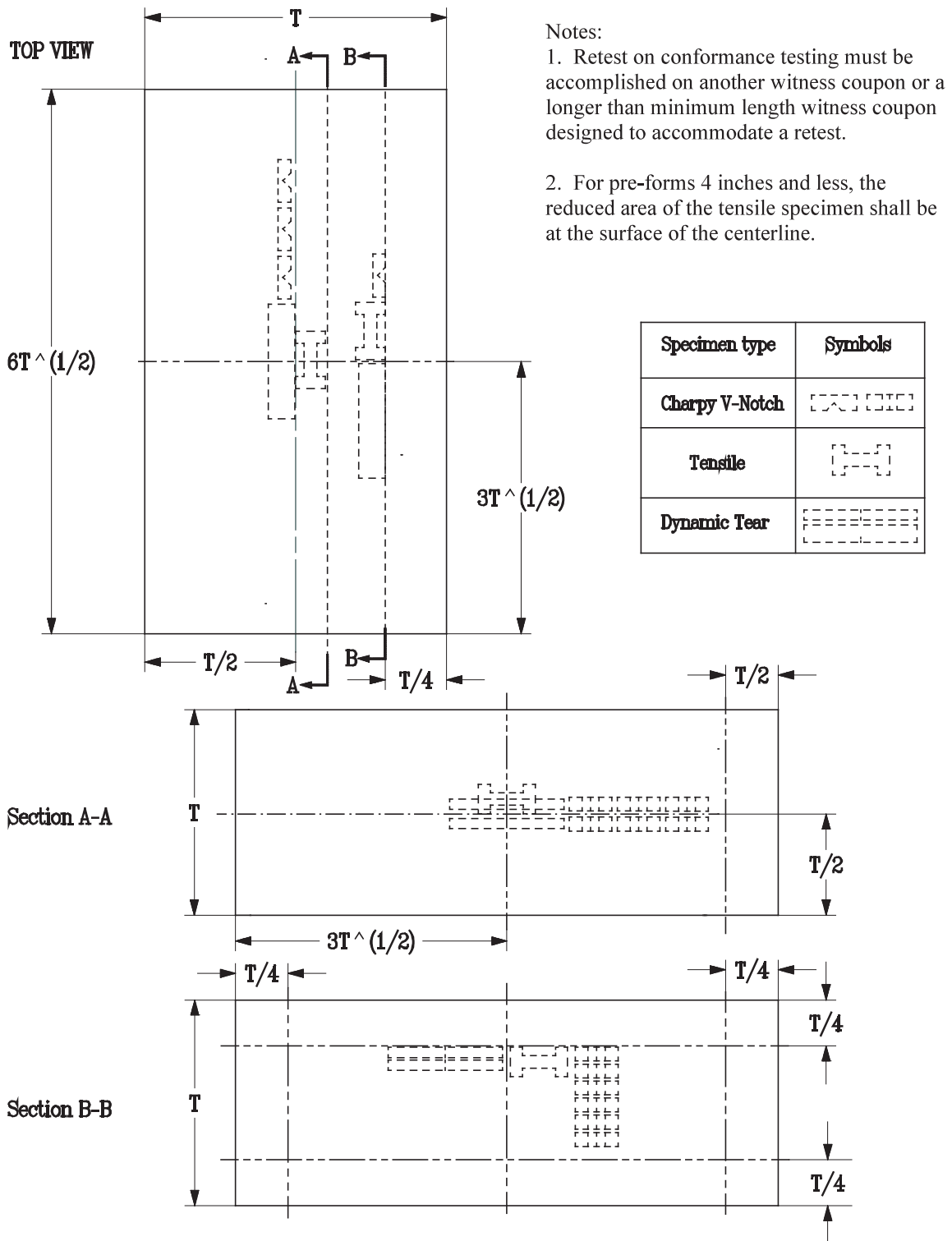

Note: Specimens in relation to one another are not to scale

Figure A-2. Schematic Diagram of Test Specimen Location for Castings Greater than 6 Inches in Thickness

**APPENDIX B
SUPPLEMENTAL TECHNICAL REQUIREMENTS TO ANSI/ASQ ISO 9001:2015**

B-1 SCOPE.

B-1.1 SCOPE. This appendix identifies the supplemental technical requirements that shall be added to the quality management systems requirements of ANSI/ASQ ISO 9001:2015 when the latter standard is specified for procurement of the base materials covered by this document.

B-2 APPLICABLE DOCUMENTS.

See Chapter 2.

B-3 REQUIREMENTS.

B-3.1 SUPPLEMENTAL REQUIREMENTS. The following supplemental requirements shall be added to the requirements of ANSI/ASQ ISO 9001:2015.

B-3.1.1 Organization Quality System.

- a. Add to ANSI/ASQ ISO 9001:2015, paragraph 4.4 - Quality management system and its processes.
The organization shall provide and maintain a quality assurance program that ensures that the product meets the contract requirements and that is acceptable to Customer and Government. The organization shall notify the customer in writing of any change, other than editorial, to the quality manual.

B-3.1.2 Coordinated Government/Organization Actions and Use of Organization Inspection Facilities.

- a. Add to ANSI/ASQ ISO 9001:2015, paragraph 8.4.3 - Information for external providers.
When, under authorization of the Government Representative, copies of the purchasing document are to be furnished directly by the supplier or organization to the Government Representative at his facility rather than through Government channels, the organization shall add to his purchasing document a statement substantially as follows:
“On receipt of this order, promptly furnish a copy to the Government Representative who normally services your plant. In the event the representative or office cannot be located, our purchasing agent should be notified immediately.”
All documents and referenced data for purchases applying to a Government contract shall be available for review by the Government Representative to determine compliance with the requirements for control of such purchases. Copies of purchasing documents required for Government inspection purposes shall be furnished in accordance with the instructions of the Government Representative.
- b. Add to ANSI/ASQ ISO 9001:2015, paragraph 8.4.2 - Type and extent of control.
The organization shall make available to the Government Representative reports of any nonconformance found on Government source-inspected supplies and shall (when requested) require the organization to coordinate with his Government Representative on corrective action.
- c. Add to ANSI/ASQ ISO 9001:2015, paragraph 8.6 - Release of products and services.
When required, the organization’s measuring and testing equipment shall be made available for use by the Government Representative to determine conformance of product with contract requirements. In addition, if conditions warrant, organization’s personnel shall be made available for operation of such devices and for verification of their accuracy and condition.

B-3.1.3 Sample Inspection.

- a. Add to ANSI/ASQ ISO 9001:2015, paragraph 9.1.3 - Analysis and evaluation.

Statistical techniques or sampling inspection procedures used for product acceptance shall be subject to approval by the customer.

B-3.1.4 Interpretation of Limits.

- a. Add to ANSI/ASQ ISO 9001:2015, paragraph 8.1 – Operational planning and control.

Where not otherwise contractually invoked, all specified limits for machining services and for dimensional control of deliverable parts and assemblies shall be interpreted as absolute limits as defined by ASTM E29. Unless otherwise specified in the contract, for all other observed, measured, or calculated product characteristics (e.g., for material suppliers, material distributors, services other than machining), specified limits shall be interpreted using round-off method as defined by ASTM E29.

B-3.1.5 Electronic Signatures.

- a. Add to ANSI/ASQ ISO 9001:2015, paragraph 8.6 - Release of products and services.

When signatures are required by the contract and will be provided electronically, protection from unauthorized changes of recorded data shall be provided.

B-3.1.6 Documented Information.

- a. Add to ANSI/ASQ ISO 9001:2015, paragraph 7.5.1 - Documented information - General.

The organization shall create a documented procedure to define the control(s) needed for Naval Nuclear Propulsion Program documented information.

- b. Add to ANSI/ASQ ISO 9001:2015, paragraph 9.3.2 - Management review inputs.

The organization shall retain the management review inputs as documented information.

B-3.1.7 Corrective Actions.

- a. Add to ANSI/ASQ ISO 9001:2015, paragraph 9.1.1 - Monitoring, measurement, analysis and evaluation - General.

The organization shall take corrective action as appropriate when planned results are not achieved.

- b. Add to ANSI/ASQ ISO 9001:2015, paragraph 10.2 - Nonconformity and corrective action.

The organization shall create a documented procedure for reacting to nonconformities including identifying the nonconformities, determining the causes of the nonconformities, evaluating the need for actions to prevent reoccurrence of the nonconformities, implementing the required actions to correct the nonconformities, reviewing the effectiveness of the corrective action taken to prevent reoccurrence of the nonconformities, updating risks and opportunities as necessary, and making changes to the quality management system as necessary.

802-8979757
